

PUNJAB STATE E-GOVERNANCE SOCIETY

GOVERNMENT OF PUNJAB, CHANDIGARH



REQUEST FOR PROPOSAL - VOLUME II

FOR

SELECTION OF DATA CENTRE OPERATOR (DCO)

TO ESTABLISH STATE DATA CENTRE IN PUNJAB

UNDER NATIONAL E-GOVERNANCE PLAN

Ref No: *SDC/Punjab/DGR/PSeGS/2013/01*



**Punjab State e-Governance Society
O/o Department of Governance Reforms
SCO 193-195, Sector 34-A, Chandigarh**

Table of Contents

ANNEXURES.....	5
1.1 Annexure I – Technical Requirements.....	5
1.1.1 Current Scenario	5
1.1.1.1. Infrastructure.....	5
1.1.2 Server and Application Set-up at SDC	5
1.1.2.1 Web Servers	6
1.1.2.2 Application Servers.....	6
1.1.2.3 Database Server.....	6
1.1.2.4 Staging Server.....	6
1.1.2.5 Backup Server.....	6
1.1.2.6 Directory Server (Enterprise Access Server)	6
1.1.2.7 Proxy Server	7
1.1.2.8 DNS/ DHCP Servers	7
1.1.2.9 Load Balancer	7
1.1.2.10 Intrusion Detection Server	7
1.1.2.11 Management Server	7
1.1.2.12 Helpdesk System.....	8
1.1.3 SDC Platform and Storage Architecture.....	9
1.1.4 SDC Network and Security Architecture.....	11
1.2 Annexure II – Technical Specifications – IT components.....	13
1.2.1 Application IT component – Application infrastructure.....	13
1.2.1.1 Application identified for Acceptance and Testing	13
1.2.2 Technical Specifications – Platform and Storage	13
1.2.2.1 Blade Chassis/ Enclosure.....	15
1.2.2.2 Application Web Server (Quantity – 5).....	16
1.2.2.2.1 Hardware specification of x64 Architecture (Quantity – 3).....	16
1.2.2.2.2 Hardware specification of RISC/EPIC Architecture (Quantity – 2).....	18
1.2.2.2.3 Software for Web Server.....	20
1.2.2.3 Application Server (Quantity - 5)	21
1.2.2.3.1 Hardware specification of x64 Architecture (Quantity – 3).....	21
1.2.2.3.2 Hardware specification of RISC/EPIC Architecture (Quantity – 2).....	23
1.2.2.3.3 Software for Application Server (Blade).....	24
1.2.2.4 Database Server (Quantity – 3)	26
1.2.2.4.1 Hardware specification of x64 Architecture (Quantity – 3).....	26
1.2.2.4.2 Software for Database Server.....	28
1.2.2.5 Staging Server.....	29
1.2.2.5.1 Hardware specification (Quantity – 1).....	29
1.2.2.5.2 Software for Staging Server	31
1.2.2.6 Storage and Backup Solution.....	32
1.2.2.6.1 Storage Hardware specification (Quantity – 1).....	32
1.2.2.6.2 Backup Solution.....	35
1.2.2.6.3 Backup Software	37
1.2.2.6.4 Backup Server Hardware.....	39
1.2.2.6.5 OS Software for Backup Server	41
1.2.2.6.6 SAN Switch (Quantity – 2)	42
1.2.2.7 Directory Services.....	44
1.2.2.7.1 Directory Service – Software	44
1.2.2.7.2 DNS, DHCP - Software specifications :	45
1.2.2.7.3 Directory Service, DNS, DHCP – Hardware (Blade).....	47
1.2.2.7.4 Operating System Software for Directory Service, DNS and DHCP	49
1.2.2.8 Anti-Virus Solution (with 50 user licenses).....	50
1.2.2.8.1 Antivirus Software specifications.....	50
1.2.2.8.2 Anti-Virus Solution – Hardware.....	53
1.2.2.8.3 OS Software Licenses for Antivirus Servers.....	55

1.2.2.9	Management Solution	56
1.2.2.9.1	Management Solution - Software Specification	56
1.2.2.9.2	Management Servers – Hardware	56
1.2.2.9.3	Software Licenses for Management Servers	58
1.2.2.10	IP KVM	59
1.2.3	Technical Specifications – IT Network Components.....	61
1.2.3.1	LAN Switch – Core.....	62
1.2.3.2	LAN Switch – Access.....	65
1.2.3.3	INTERNET Router	67
1.2.3.4	Firewall Internet.....	71
1.2.3.5	Intrusion Prevention System - Internet	73
1.2.3.6	End Point Protection for Servers and PCs (HIDS/ HIPS).....	77
1.2.3.7	Server Load Balancer (Qty: 1+1).....	81
1.2.3.8	Authentication, Authorization and Accounting (Qty: 1).....	83
1.2.4	SDC EMS Architecture.....	85
1.2.4.1	Technical Specifications - EMS.....	97
1.2.4.1.1	Hardware Specification (Quantity – Minimum 3 Servers)	97
1.2.5	Functional requirement for Disaster Recovery Management Software	98
1.2.6	Functional requirement Specification for Cloud	101
1.2.6.1	General Requirment.....	101
1.2.6.2	Functional Requirment Specification(FRS) for Cloud Enablement	102
1.2.7	Security Components	112
1.3	SDC Architecture – Physical Infrastructure	116
1.3.1.1	Layout of Data Centre.....	116
1.3.1.2	Technical Specifications – Civil and Interior Work	117
1.3.1.2.1	Modes of Measurement.....	122
1.3.1.3	Technical Specifications – Electrical	124
1.3.1.3.1	UPS, Batteries and Accessories.....	124
1.3.1.4	Technical Specification – Diesel Generating Sets.....	140
1.3.1.5	Technical Specifications – Electrical: Low Side	158
1.3.1.6	Technical Specifications – Supply And Installation Of Low Voltage Cables	177
1.3.1.7	Technical Specifications: Low Voltage Systems	180
1.3.1.8	Technical Specifications – Light Fixtures.....	190
1.3.1.9	Technical Specification - Earthing System.....	191
1.3.1.10	Technical Specifications – Change Over Switch for PAC.....	194
1.3.1.11	Technical Specifications – Air Conditioning	195
1.3.1.11.1	Precision Air Conditioning.....	195
1.3.1.11.2	Technical Specifications – Comfort AC.....	198
1.3.1.12	Technical Specification – Integrated Building Management System	200
1.3.1.13	Technical Specification – Addressable Fire Alarm System	236
1.3.1.14	Access ControlSystem	261
1.3.1.15	Surveillance CCTV System.....	269
1.3.1.16	NOVEC1230 OR INERGEN GAS BASED FIRE SUPPRESSION SYSTEM.....	274
1.3.1.17	Rodent Repellant System	276
1.3.1.18	Smoke detection Syste.....	277
1.3.1.19	Water Leak Detection System.....	287
1.3.1.20	Technical Specification – Passive Networking	290
1.3.2	Bill of Quantity – Physical Quantity Civil and Interiors	296
1.3.2.1	Bill of Quantity: Electrical System	310
1.3.2.2	Bill of Quantity: Air Conditioning System	325
1.3.2.3	Bill of Quantity: Safety and Security Systems	330
1.3.2.4	Bill of Quantity: Passive Networking.....	339
1.3.3	Bill Of Quantity: Networking Components	342
1.3.4	Bill Of Quantity: Management, Monitoring & Helpdesk SYSTEM (EMS)	343
1.3.5	Bill Of Quantity: Platform and Storage	344
1.3.6	Bill of Quantity: Software Licenses.....	346
1.3.7	Bill of Quantity : Additional Component.....	350

1.4	Annexure II: Indicative Proposed SDC Layout	351
1.5	Indication Layout plan for Main Sub-station and DG station.....	352
1.6	Annexure III : Single Line Diagram (Electrical) - Tentative	353
1.7	Annexure IV: Load Calculation Sheet	354

Annexures

1.1 Annexure I – Technical Requirements

1.1.1 Current Scenario

Punjab SWAN and SDC are proposed to be co-located. Punjab state is going for a new state data center to host all the upcoming applications.

A typical new SDC architecture is being depicted in the schematic below:

1.1.1.1. Infrastructure

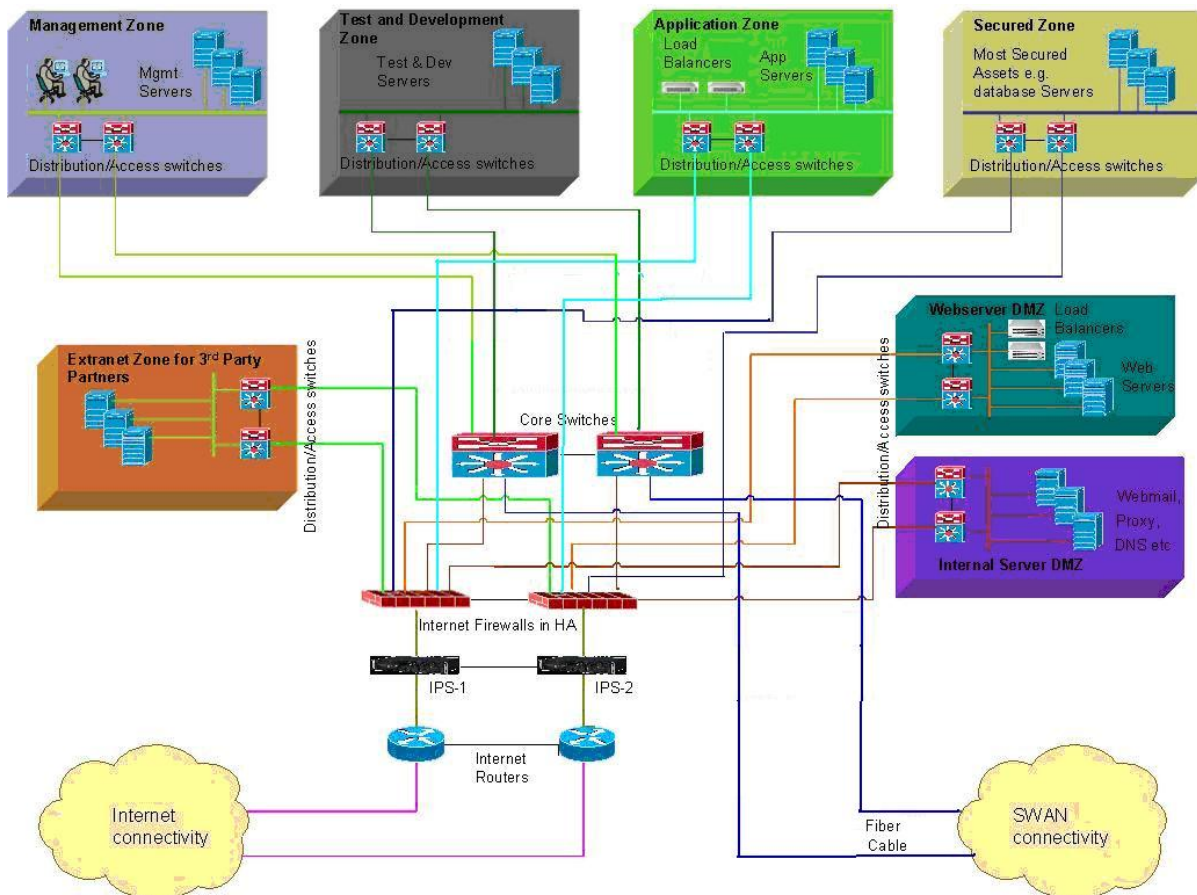

Bidder should study and refer the detailed diagram pasted above for the proposed state data center. Bidder should come up with a network solution based on this diagram and hence the diagram shown above is not the final network diagram.

1.1.2 Server and Application Set-up at SDC

SDC would be hosting various e-governance applications, an information portal, Citizen centric service applications and multiple databases. In order to meet these expectations various application servers/ systems would be required such as:

1.1.2.1 Web Servers

Web based applications are easily accessible from any sort of the network, Intranet, internet or extranet. Therefore, Web server plays a vital role in SDC. Most of the new application are having web interface, which requires web servers for such services. The web servers would also be used for web hosting for different department

1.1.2.2 Application Servers

Application would be required as middle tier for various web based applications. Application server would take care of the necessary workflow and web server would be required for the interfacing with the end user. Both the web and application server would be seamlessly integrated to provide high availability and performance. It is proposed to have two separate applications solutions for Unix/ Linux and Windows environment.

1.1.2.3 Database Server

The database/ repository provides all the relevant information required to process any Citizen/ Government request or to render any e-Governance services with the use of SDC. Database server would be required to store and access data with ease. This would also be integrated with multiple applications, residing at SDC. Database servers should be configured in highly available mode.

1.1.2.4 Staging Server

It would be required to deploy a separate server as Staging server where all the new services are deployed before it is brought on to the production servers.

1.1.2.5 Backup Server

Backup server would be used for backing up the data at regular interval. The backing up of the data would be an automated process. Whenever desired the backed up data can be restored retrieved to the desired system configuration.

1.1.2.6 Directory Server (Enterprise Access Server)

Using Directory services SDC administrator should be able to define centralized authentication & authorization mechanisms for users. This would enable associate policies such as security, management etc on all servers/ systems from a centralized console and enhances security, reduces IT complexity and increase overall efficiency. It should be LDAP v3 compliant, in order to have integrated interoperability, security & manageability. It would also enable central authentication thus enabling single sign-on (SSO) mechanism. Therefore this user directory would enable easy manageability that is creation, modification and deletion of user records. It would further help to integrate with various other services like messaging, proxy, etc. The directory services should also be able to cater the requirements of the State for client

workstations also.

1.1.2.7 Proxy Server

Proxy Server will be used in neighborhood of one or more web servers, all the traffic from internet destined to one or more web server goes through proxy server. Proxy server will also be configured in SDC to enforce internet access policy and caching of static contents.

1.1.2.8 DNS/ DHCP Servers

DNS server would be required for various website and web application hosted for public/ Govt. access. The internet users will query for the domains on the DNS (Public DNS) server deployed at the SDC. DHCP would be assisting the System administrators for dynamic IP allocation to devices/ users. Furthermore, the key users (require SDC services), who would be connecting using remote access, would be requiring a valid IP address after successful authentication.

1.1.2.9 Load Balancer

The load balancer would be required for distributing workloads to a set of networked computer servers in such a manner that the computing resources are used in an optimal manner. The load balancer should support segmentation to distribute load for multiple services, servers. This would increase the availability of the server and should also increase the performance as multiple servers would be sharing the service load. The load balancer would be used for the following servers:

- Application Server
- Web Servers
- Database Servers
- Integartion Servers

1.1.2.10 Intrusion Detection Server

Any attempts of intrusion over a network should be detected and logged into a database, which should form the basis of reports generated. This would provide proactive information while the network is being compromised based on certain network patterns detected.

1.1.2.11 Management Server

The management server would help in administration of distributed systems at SDC. The management server would help in efficient and reliable administration of all the distributed computing devices and enable:

- Inventory Management
- Patch management
- Monitor the availability of Services

- Fault Management
- Performance Management

1.1.2.12 Helpdesk System

An ITIL based Helpdesk system would be used for assisting the service delivery by DCO for SDC. Helpdesk system would automatically generate the incident tickets and log the call. Such calls are forwarded to the desired system support personnel deputed by the DCO. These personnel would look into the problem, diagnose and isolate such faults and resolve the issues timely. The helpdesk system would be having necessary workflow for transparent, smoother and cordial SDC support framework.

- Provide flexibility of logging incident manually via windows GUI and web interface.
- The web interface console of the incident tracking system would allow viewing, updating and closing of incident tickets.
- System should provide Knowledge base
- Provide seamless integration to events/incident automatically from NMS / EMS.
- Allow categorization on the type of incident being logged.
- Provide classification to differentiate the criticality of the incident via the priority levels, severity levels and impact levels.
- Each incident could be able to associate multiple activity logs entries manually or automatically events / incidents from other security tools or EMS / NMS.
- Provide audit logs and reports to track the updating of each incident ticket.
- Proposed incident tracking system would be ITIL compliant.
- It should integrate with Enterprise Management System event management and support automatic problem registration, based on predefined policies.
- It should be able to log and escalate user interactions and requests.
- It should provide status of registered calls to end-users over email and through web.

1.1.3 SDC Platform and Storage Architecture

This section of the RFP outlines platform and storage components to be deployed as part of SDC project. Majority of e-Governance applications are developed for Windows and Unix Operating System on x86 and RISC/ EPIC hardware platform. Server farm will be comprised of hardware for Directory service, Proxy Service, Antivirus service, DNS and DHCP Service, Backup service and Server for Enterprise Management suite. Other IT components appear under Optional components section as part of SDC deployment is subject to Punjab State decision. Apart from the core infrastructure components listed above, hardware has to be proposed for the three tier application architecture viz. Front end web server, application server and Database server.

The diagram below illustrates the application infrastructure for e-Governance application. The e-Governance applications have three-tier architecture, RDBMS software is used at backend, in-house application or commercial application are at mid-tier and Web Servers are at the front-end of Tier-three architecture of e-governance application. Application at the all levels of Tier-three architecture shall be in highly available mode. All the Servers part of IT infrastructure shall be organized into different zones as per reference diagram in the section 1.1.1.2 and specification given below.

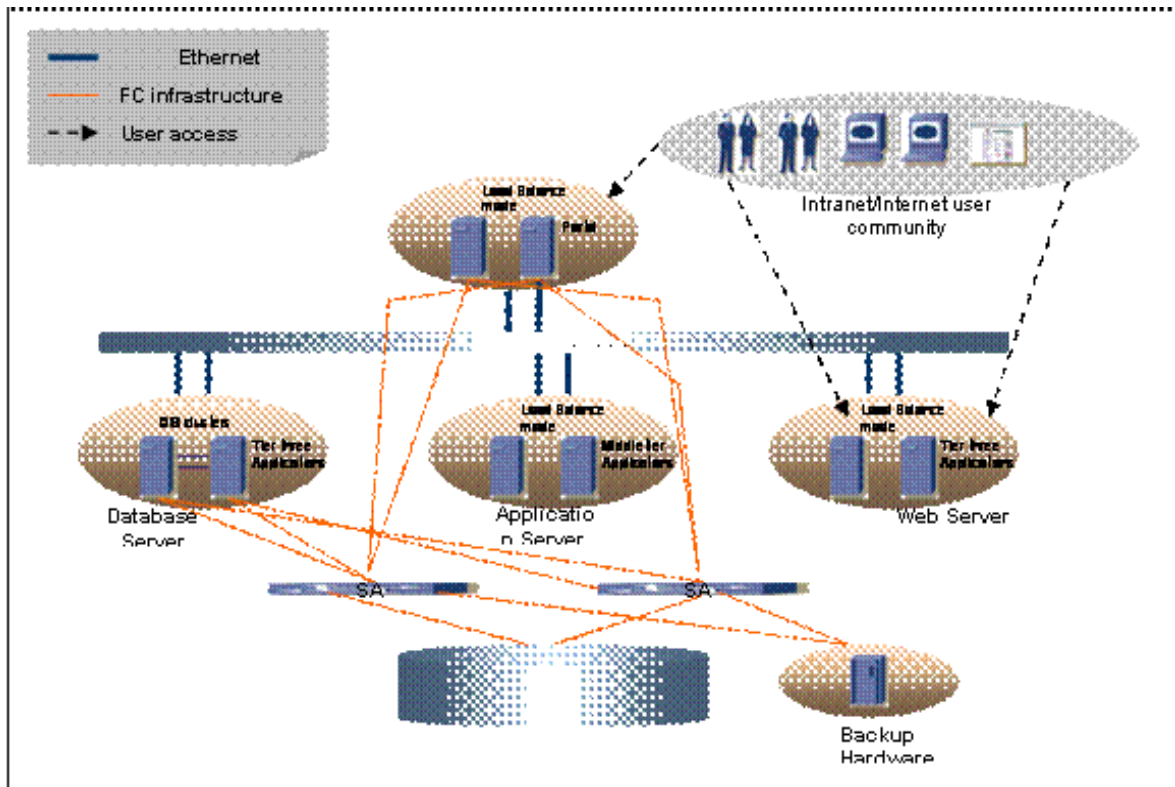

- DNS/DHCP should be in highly available mode with primary and secondary servers. There should be two different views or servers for public and private DNS services.
- There should be at least one primary and one secondary Directory server configured in such a way that directory services are available 100% of the time
- There should be a redundancy at DNS and DHCP level which can be on a load balanced or Primary Secondary mode. Two separate instances of DNS have to be created with two different views. The two instances are for internal (Intranet) and external (Internet) usage. The external instance view is only available to external (internet) users and the internal view is only available to internal/ intranet servers. Separate view has been created for external lookups. Domain name would be same for external and internal usage.
- Web servers facing external world should be placed in DMZ internet zone in load balanced mode using external load balancer.
- All Database servers should be placed in secured zone in highly available configuration.
- Application servers which provides business logic and work flow should be placed in secured zone in high available mode
- Server and Network/ Security Management servers should be located in management zone
- Staging servers are used for development, testing and pre-production activities should be located in separate test and development zone
- All the proposed servers should be configured with 32/ 64 bit Enterprise operating system.
- Since, Consolidation and is a trend and requirements of any upcoming Data Center, Vendors are encouraged to design the solution to meet Consolidation requirement of Data Center.
- State Government intends to host all state government applications pertaining to various divisions and departments in a single location with commitment of better service and availability to end users, it is imperative that availability of the proposed solution should be high by design. Bidders should establish in his technical proposal, how the same is proposed from a stand alone component level as well as an overall solution level.
- Bidders shall propose changes to design to value add, if applicable.
- Bidder shall supply all end-to-end components for LAN / SAN connectivity of servers and Storage.
- Bidder may propose alternative solutions (other than BOM proposed in RFP) inline with the standards, guidelines provided in the RFP and to meet SDC objectives and SLA's.
- The Servers need to be stateless to support network virtualization as part of the cloud for the servers.
-

1.1.4 SDC Network and Security Architecture

Network should meet requirements for various kinds of Internal & External users in the state. Network Architecture shall be scalable and should have high performance and low latency. All the critical network equipments as Core Switches, Routers, Firewalls etc should be offered with redundant power supply or wherein redundant power-supply is not possible redundancy should be provided across different hardware.

All these equipment should get electrical feed from alternative power source/ UPS/ power-socket. The connectivity between end user equipment and access layer switches over Cat6 UTP cabling at Gigabit speed.

The state data center network is envisaged as mentioned below:

- Network should be multi-tier architecture comprising collapsed Access/ distribution and core.
- Network System infrastructure should be based on converged IP technology from the Core through to the Access layer.
- Core Switches shall be in high availability mode..
- LAN system should provide at least 50% scalability with enough free slots in Core & Access switches.
- For Securing the SDC, the Intrusion prevention systems shall carryout state-full inspection and multiple layers of Firewalls shall manage the access control.
- In this secure infrastructure it has to be ensured that the security devices in the network such as Firewalls, IPS are in high-availability mode.
- Pair of routers will be used for connecting the SDC to INTERNET world.
- Pair of firewalls will be used for INTERNET connectivity.
- Outside zone or public zone of INTERNET firewall will be connected to the INTERNET router.
- Web servers would be placed in a separate DMZ of INTERNET firewall.
- Third party servers would be placed in a separate DMZ of INTERNET firewall.
- Inside zone or Military Zone (MZ) of firewall get connected to core switch.
- Second layer of INTRANET firewall will be used behind the core switch as well.
- Management servers would be placed in a separate DMZ of INTRANET firewall.
- Test and Development servers would be placed in a separate DMZ of INTRANET firewall.
- Application servers would be placed in a separate DMZ of INTRANET firewall.
- Database servers would be placed in inside zone or MZ of INTRANET firewall.

- Intrusion prevention system should detect malicious traffic and further protect the SDC environment from INTRANET and INTERNET world.
- Critical Components would be in high availability mode.
- Bidder may propose alternative solutions (other than BOM proposed in RFP) inline with the standards, guidelines provided in the RFP and to meet SDC objectives and SLA's.

1.2 Annexure II – Technical Specifications – IT components

1.2.1 Application IT component – Application infrastructure

The proposed Data Center will host various Infrastructures/e-Governance applications, for its various service offerings and it requires Hardware, Operating System, Storage and Network platform to host Infrastructure/e-Governance applications. Infrastructure/E-Governance Application to be deployed has a various workload requirements and IT offers varieties of Technologies and Products to meet requirement. With the emphasis on effective utilization Data Center facility, power and workload requirement of various applications, it is proposed to have Blade System solution for Infrastructure workload application such as Web Server, Application Server, DNS, DHCP, Proxy, Anti-virus, Directory Service and EMS suite applications. Database Server to be setup on Rack mount servers.

1.2.1.1 Application identified for Acceptance and Testing

SUWIDHA application has been selected by the PSEGS for hosting & Final Acceptance Test at SDC.

SUWIDHA application uses Windows Environment with SQL 2008 Database

- Application migration is not the responsibility of the DCO.
- Application enhancement is not the responsibility of the DCO.
- DCO would only provide hardware and infrastructure and facilitate in migration of the application to the SDC

• IT related details of SUWIDHA Application

Operating System	:	Windows 2008 Server
Development Tools	:	visual studio 2010, SQL Server
Database	:	SQL Server 2008

1.2.2 Technical Specifications – Platform and Storage

Following are different types of equipment configurations that shall be required for the State Data Center (SDC). Items and the configurations categorically mentioned below are the configurations required for the Implementation of SDC architecture.

Any thing proposed by bidder over and above the minimum required specs are acceptable; however, anything that is below the minimum mentioned requirement even in a single specification may get the

bid disqualified. Therefore, the bidder has to ensure that minimum specifications are match at least with adequate no. licenses valid for the project period. The bidder has to include this as the part of the technical proposal with the make and model numbers.

The solution elements given by the bidder should comply with the specifications of various devices mentioned below. **Bidder shall have the responsibility to make the solution work and hence any additional components that might be required for the solution to work shall be provided by the bidder at their own cost and within the implementation schedule.** Those components should be listed in separate table in technical bid and each of its specification should be mention with Make, Model with adequate number of licenses (valid for the project period) of OS, Database, others etc

: Bidder has to provide all the required latest System Software (OS, DBMS, Anti virus etc) including adequate number of licenses as per the hardware mentioned, updates, patches OEM support packs etc. valid for the project period to ensure that the system is properly updated.

: Licensing : DCO has to provide all adequate number of licenses (for SDC users, internet user etc.) of software to meet the solution which shall be valid for the project period. The DCO has to produce evidence/ licenses to Tendering Authority.

: All accessories (Soft, Hard, Cables (Power, Data, HBA etc.) etc.) required for any kind of components/ equipments to be installed in SDC shall be arranged by DCO at its own cost

Note: Bidder should ensure that the proposed solution should support the virtualization and the Servers, Operating System should also support virtualisation.

1.2.2.1 Blade Chassis/ Enclosure

S.No	Description	Quantity	Pg where the functionality/ specification mentioned	No. the
Blade Chassis/Enclosure for blades (from same OEM Make & Model)		As per Solution Requirement		
Sno.	Component	Desired Specifications	Compliance/ Deviation	
1.	Make Offered	Mention Make		
2.	Model Offered	Mention Model		
3.	Certification(s) Required	OEM - ISO 9001 Manufacturer		
4.	Form Factor	Mention chassis height in RU		
5.	Blade Chassis/Enclosure shall have a provision to accommodate a minimum of 8 Blade Server modules (all the blader slots should be ready for new blade to be inserted)			
6.	Blade enclosure should capable to accommodate Intel/ AMD/ Itanium processors.			
7.	Blade Chassis shall accommodate hot swappable Interconnect Modules, Power supplies, Fans, Management Modules etc.			
8.	It shall include all accessories so that it can be mounted on an Industry Standard 36 U Rack.			
9.	It must have a optical dvd drive (latest speed) and atleast one USB port accessible to all blades			
10.	It shall have all required 100% redundant: <ul style="list-style-type: none"> • Power Supplies, • Network interface, • Fiber Channel interface, • management module (automatic failover) etc. 			
11.	It shall be supplied with the PDUs to connect Power Cables to the Chassis powerinput terminals.			
12.	It shall be fully populated with fans for cooling with 100% redundancy built in for the entire enclosure & its components.			
13.	Management Module which provides a single point of control for intelligent management of the entire console. It should provide setup & Control of Enclosure, should report asset and inventory			

	Information for all the devices in the Enclosure. It should report Thermal & Power Information of per Server and it should provide IP KVM functionalities & Access for all the Server Blades from the Management Module.		
14.	Management Modules per Blade/ Chassis providing system management function and remote management		
15.	Service and management : Multiple administrators to remotely access and maintain multiple server blades simultaneously		
16.	Require two communication modules with support of load balancing and failover		
17.	Chassis should be populated with maximum power supplies for scalability purpose at the time of bidding.		

1.2.2.2 Application Web Server (Quantity – 5)

1.2.2.2.1 Hardware specification of x64 Architecture (Quantity – 3)

S.N	DESCRIPTION		QTY	Deviation
	Blade Server for Application Web Server		3	
Sr. No.	Specifications		Compliance	Deviation
			(Yes/No)	(If any)
1.	Make Offered	Mention Make		
2.	Model Offered	Mention Model		
3.	Certification(s) Required	OEM - ISO 9001 Manufacturer		
		Certified on proposed OS(s)		
4.	Std. Compliance(s) Req.	UL, FCC & RoHS		
5.	Server Form Factor	Blade to be inserted into above blade enclosure		
6	CPU: 1 x Quad Core x64 processor Scalable upto 2 * Quad core Processor. Processor speed should be of Min 2.00 GHz			

7	Memory: 32 GB Memory scalable up to 64 GB		
8	Hard Disk Drive: 2x 146 GB or higher capacity disk of 10K or higher RPM hot plug SAS HDD		
9	Multi function Port: Minimum 4 x 1 Gigabit NIC ports per Blade Server		
10	Keyboard: Virtual KVM based remote control		
11	Hard Disk Controller: SAS based supporting RAID 0 , 1		
12	Management: OS independent hardware health status		
13	Shall support 64 bit Linux/Windows Operating System platform		
14	Out of 3 servers, Bidder shall propose Two servers with MS Windows Enterprise Operating System in cluster (1+1) and one server with Red Hat Linux /Unix OS. Proposed Operating System software & cluster software should be of latest version		
15	Blade Chassis/Enclosure: (Section 1.2.1.2)		

1.2.2.2.2 Hardware specification of RISC/EPIC Architecture (Quantity – 2)

S.N	DESCRIPTION	QTY	Page Reference in product data sheet
	Application Web Server – Rack Server	(2 No:)	
S.No.	Specifications	Compliance	Page Reference in product data sheet (If any)
	Hardware features	(Yes/No)	
I	Hardware specification for Web Server & Application server of RISC/EPIC Architecture --- 64-bit Server with latest generation of RISC/EPIC Processor with latest clock speed & highest Cache available at the time of bidding across quoted class of machine CPU – 4 core scalable to 8 core. CPU speed 1.6 GHZ or more		
III	32 GB RAM scalable up to 128 GB.		
IV	Min 2 x 146 GB 10K RPM hot swappable SAS HDD		
V	The server should have the following connectivity option : 2*4 Gbps Fibre Channel, 4 * 1Gbps Ethernet Ports		
VII	1 DVD Drive		
VIII	Redundant, hot swappable, power & cooling units		

IX	<p>Bidder shall propose 64 bit Enterprise latest version Operating System . Latest version of UNIX Operating System (64 bit) with media and documentation for the system to be provided.</p> <p>The OS should be supplied with CPU based license.</p> <p>Moreover the Proposed Unix Operating system should be compatible with the RDBMS which shall be deployed on the proposed servers.</p>		
----	---	--	--

1.2.2.2.3 Software for Web Server

S.No	Description		Quantity License	Pg No. where the functionality/ specification mentioned
Software Specification for Web Server				
1.	Operating System(s) / Softwares should be of latest version with license, req. media, docs for entire project period Etc	a. MS Windows Enterprise Server OS with adequate no. of licenses as per the hardware mentioned above with updates, patches, OEM support pack etc. valid for project period	2	
		b. Linux Operating System with adequate no. of licenses as per the hardware mentioned above with updates, patches, OEM support pack etc. valid for project period	1	
		c. License for use of the server over Internet by citizen « Windows Server External Connector » due to some application designed for IIS	1	
		d. 64 bit Enterprise latest version Operating System . Latest version of UNIX Operating System (64 bit) with media and documentation for the system to be provided. The OS should be supplied with CPU based license. with updates, patches, OEM support pack etc. valid for project period	2	

1.2.2.3 Application Server (Quantity - 5)

1.2.2.3.1 Hardware specification of x64 Architecture (Quantity – 3)

S.N	DESCRIPTION		QTY	Deviation
	Blade Server for Application		3	
Sr. No.	Specifications	Desired Specification	Compliance (Yes/No)	Deviation (If any)
1.	Make Offered	Mention Make		
2.	Model Offered	Mention Model		
3.	Certification(s) Required	OEM - ISO 9001 Manufacturer		
		Certified on proposed OS(s)		
	Std. Compliance(s) Req.	UL, FCC & RoHS		
4.	Server Form Factor	Blade to be inserted into above blade enclosure		
5	CPU: 1 x Quad Core x64 processor scalable up to 2 * Quad Core Processor. Processor speed should be of Min 2.00 GHz			
6	Memory: 32 GB Memory scalable up to 64 GB			
7	Hard Disk Drive: 2x 146 GB 10K or higher RPM hot plug SAS HDD			
8	Multi function Port: Minimum 4 x 1 Gigabit NIC ports per Blade Server			
9	Remote Administration : Should have network			

	management port for remote administration			
10	Keyboard: Virtual KVM based remote control			
11	Hard Disk Controller: SAS based supporting RAID 0 and 1			
12	Management: OS independent hardware health status			
13	Shall support 64 bit Red Hat Linux/Windows/Unix Operating System platform			
14	Bidder shall propose Two servers with MS Windows Enterprise Operating System in cluster (1+1) and one server with Red Hat Linux/ Unix OS . Proposed Operating System software & cluster software should be of latest version. The cluster where ever being provided should be of the same OEM as the OS.			
15	Blade Chassis/Enclosure: (Section 1.2.1.2)			

1.2.2.3.2 Hardware specification of RISC/EPIC Architecture (Quantity – 2)

S.N	DESCRIPTION		QTY	Page Reference in product data sheet
	Application Server- Rack Server		(2 No.)	
S.No.	Specifications		Compliance	Page Reference in product data sheet (if any)
			(Yes/No)	
	Make Offered	Mention Make		
	Model Offered	Mention Model		
	Certification(s) Required	OEM - ISO 9001 Manufacturer		
		Certified on proposed OS(s)		
	Std. Compliance(s) Req.	UL, FCC & RoHS		
	Server Form Factor	Blade to be inserted into above blade enclosure		
I	Hardware specification for Web Server & Application server of RISC/EPIC Architecture --- 64-bit Server with latest generation of RISC/EPIC Processor with latest clock speed & highest Cache available at the time of bidding across quoted class of machine CPU – 4 core scalable to 8 core. CPU speed 1.6GHZ or more			
II	The server /Operating System should support Cluster software & Volume manager software			
III	32 GB RAM and scalable up to 128 GB			
IV	Min 2x146GB 10K RPM SAS HDD.			
V	4 x 1 Gigabit Ethernet Ports			
VI	Should have network management port for remote			

	administration.		
VII	2* 4 Gbps Fibre Channel dual ported		
VIII	1 DVD Drive		
IX	Redundant, hot swappable, power/cooling units		
X	<p>Bidder shall propose 64 bit Enterprise latest version Operating System. Latest version of UNIX Operating System (64 bit) with media and documentation for the system to be provided.</p> <p>The OS should be supplied with CPU based license.</p> <p>Moreover the Proposed Unix Operating system should be compatible with the middleware software and the RDBMS which shall be deployed on the proposed servers.</p> <p>The cluster where ever being provided should be of the same OEM as the OS.</p>		

1.2.2.3.3 Software for Application Server (Blade)

S.No	Description		Quantity License	Pg No. where the functionality/ specification mentioned
	Software for Application Server			
1.	Operating System(s) (Software should be of latest version with license, req. media, docs for entire project period Etc)	a. MS Windows Enterprise Server OS with adequate no. of licenses as per the hardware mentioned above with updates, patches, OEM support pack etc. valid for project period	2	
		b. Linux Operating System with adequate no. of licenses as per the hardware mentioned above with updates, patches, OEM support	1	

		pack etc. valid for project period		
		<p>64 bit Enterprise latest version Operating System. Latest version of UNIX Operating System (64 bit) with media and documentation for the system to be provided.</p> <p>The OS should be supplied with CPU based license.</p> <p>Moreover the Proposed Unix Operating system should be compatible with the middleware software and the RDBMS which shall be deployed on the proposed servers.</p>	2	
2.	Application Software	a. Tomcat	1	

1.2.2.4 Database Server (Quantity – 3)

1.2.2.4.1 Hardware specification of x64 Architecture (Quantity – 3)

S.N	DESCRIPTION		QTY	Deviation
	Database Server (Rack Server)		3	
S.No.	Specifications		Compliance	Deviation (If any)
			(Yes/No)	
1.	Make Offered	Mention Make		
2.	Model Offered	Mention Model		
3.	Certification(s) Required	OEM - ISO 9001 Manufacturer		
		Certified on proposed OS(s)		
	Std. Compliance(s) Req.	UL, FCC & RoHS		
4.	Server Form Factor	Rack mountable. Please mention server height in U		
5.	Performance Required	CACHE to provide minimum performance of 600000 TPMC/12000 SAPs		
6.	2 * Quad Core x64 processor capable of delivering minimum 600000 TPMS/ 12000 SAPs scalable upto 4*Quad Core x64 processor capable of delivering minimum 1200000 TPMS/ 24000 SAPs. Processor speed should be of Min 2.13 GHz			
7.	Processor should be latest series/ generation for the server model being quoted			
8.	128 GB memory scalable up to 512 GB.			
9.	Min 2 x 300 GB or higher SAS HDD hot plug drives			
10.	RAID Controller support : RAID 0 & 1			
11.	2 * 1Gbps (full duplex per port) Dual Ethernet port			
12.	Should have network management port for remote administration			
13.	Fiber Channel ports 2 x dual port 4Gbps			

14.	SAN HBAs should be connected on separate slots for high throughput and redundancy requirement		
15.	System should support RAS features as CRC, Memory Mirroring and Detailed Log Collection.		
16.	All cards should be on 64 bit PCI-X/PCI-e slots operating at minimum 133MHz. Independent PCI for better I/O.		
17.	2 no. of Dual HBA card with minimum 4Gbps per port, along with the required cables for connectivity to Storage subsystem. HBA should support storage subsystems of leading manufactures like EMC, Hitachi, HP, IBM, SUN etc. SAN HBAs should be connected on separate slots for high throughput and redundancy requirement.		
18.	HBA should support Microsoft and Linux / Unix Operating Systems		
19.	HBA load balancing / Multi-path software should be provided as part of solution		
20.	1 DVD Drive with latest available speed		
21.	Redundant, hot swappable, power & cooling units		
22.	Scaling of CPU and Memory to maximum capacity should be possible without adding Chassis/Enclosure/CPU Board Or Memory Board		

1.2.2.4.2 Software for Database Server

S.No	Description		Quantity License	Pg No. where the functionality/ specification mentioned
Software for Database Server				
1.	Operating System(s) / Softwares should be of latest version with license, req. media, docs for entire project period Etc	a. 64 bit MS Windows Enterprise Server OS with adequate no. of processor based licenses as per the hardware mentioned above with updates, patches, OEM support pack etc. valid for project period. Proposed Operating System software & cluster software should be of latest version and of the same OEM as of OS	2 (1+1 MS Cluster)	
		b. 64 bit Linux/Unix Operating System with adequate no. of licenses as per the hardware mentioned above with updates, patches, OEM support pack etc. valid for project period	1	
		c. Enterprise MS-SQL DBMS along with adequate no. of licenses as per the hardware mentioned above with updates, patches, OEM support pack etc. valid for project period	2	
		d. 64 bit post-gress / my-sql open source database management software. Software proposed should be of latest version for Linux/Unix Platform	1	

1.2.2.5 Staging Server

1.2.2.5.1 Hardware specification (Quantity – 1)

S.N	DESCRIPTION		QTY	Deviation
	Staging Server – Rack Server		1	
S.No.	Specifications		Compliance	Deviation (If any)
			(Yes/No)	
1.	Make Offered	Mention Make		
2.	Model Offered	Mention Model		
3.	Certification(s) Required	OEM - ISO 9001 Manufacturer		
		Certified on proposed OS(s)		
4.	Std. Compliance(s) Req.	UL, FCC & RoHS		
5.	Server Form Factor	Rack mountable, pl. mention server height in U		
6	2 * Quad Core x64 processor. Processor speed should be of Min 2.13 GHz			
7	Processor should be latest series/generation for the server model being quoted			
8	Should have support for 64 bit Linux/Windows/unix OS platform			
9	64 GB memory scalable up to 256 GB			
10	Min 4x 146 GB 10K RPM or higher SAS HDD			
11	4 * 1 Gigabit Ethernet Ports			
12	Should have network management port for remote administration			
13	All cards should be on 64 bit PCI-X/PCI-e slots operating at minimum 133MHz or higher			
14	1 DVD Drive			
15	HBA : 2 x dual port 4Gbps			
16	HBA should support storage subsystems of leading			

	manufactures like EMC, Hitachi, HP, IBM, SUN etc		
17	HBA should support Microsoft and Linux/Unix Operating Systems		
18	Redundant, hot swappable, power/cooling units		
19	System should have capability to support virtualization software		
20	RAID Controller: RAID controller to support various levels of RAID		
21	<p>Vendor shall propose one set of 64 bit Enterprise MS Windows OS & one set of 64 bit Enterprise Red Hat Linux/UNIX Operating system for proposed hardware. Proposed Operating System should be of latest version.</p> <p>The cluster where ever being provided should be of the same OEM as of the OS.</p>		

1.2.2.5.2 Software for Staging Server

S.No	Description		Quantity License	Pg No. where the functionality/ specification mentioned
Software for Staging Server				
1.	Operating System(s) / Softwares should be of latest version with license, req. media, docs for entire project period Etc	a. MS Windows Enterprise Server OS with adequate no. of licenses as per the hardware mentioned above with updates, patches, OEM support pack etc. valid for project period	1	
		b. Enterprise MS-SQL DBMS along with adequate no. of licenses as per the hardware mentioned above with updates, patches, OEM support pack etc. valid for project period	1	
		c. one set of 64 bit Enterprise Red Hat Linux/UNIX Operating system for proposed hardware.	1	

1.2.2.6 Storage and Backup Solution

1.2.2.6.1 Storage Hardware specification (Quantity – 1)

S.N	DESCRIPTION		QTY	Page Reference in product data sheet
	Storage		(1 No)	
S.No.	Specifications		Compliance	Page Reference in product data sheet (If any)
			(Yes/No)	
1.	Make Offered	Mention Make		
2.	Model Offered	Mention Model		
3.	Certification(s) Required	OEM - ISO 9001 Manufacturer		
4.	Rackmountable			
5	RAID Controller: RAID controller should support various levels of RAID (RAID 0, RAID 1, RAID 5/6, RAID 10 etc)			
6	The storage subsystem proposed should have no single point of failure with respect to controller, cache, disks, power supply and cooling			
7	It should support Non-disruptive component replacement of controllers, disk drives, cache, power supply, fan subsystem etc.			
8	<i>The Storage array or subsystem shall support SATA/ NL_SAS/FATA/SSD and FC/SAS disks etc</i>			
9	<i>The storage subsystem shall support 450/600 GB FC/SAS HDD @15K RPM and 500GB or Higher SATA/FATA or NL-SAS disk drives.</i>			
10	Storage subsystem shall support Global hot spare or universal hot spare disks			
11	"The Storage subsystem shall be configured with minimum of 8GB DRAM cache memory per controller total of 16GB."			

12	It shall support non disruptive online micro code upgrades		
13	It shall support de-staging of cache to disks on power down or shall support internal battery backup of cache for at least 48 hours. The data in cache shall not be lost in the case of power failure.		
14	System should be configured with necessary multi - pathing & load-balancing components for high availability		
15	The design shall also provide support for LUN masking and SAN security.		
16	The storage architecture shall have 1+1 active – active storage controllers and mirrored cache, with no single point of failures.		
17	“Each storage controller shall support minimum 4 front-end FC ports and 4 backend FC/ SAS ports. Each FC port shall support minimum 4Gbps rated bandwidth”.		
18	The storage system shall support the latest OS releases & Cluster of the following mentioned servers / OS:- CISC/ RISC/ EPIC-based Servers running Microsoft, HP, IBM, Sun, Linux		
19	The storage shall support the following High Availability Clusters solution from HP, IBM, Symantec, EMC , SUN and Windows		
20	The storage shall support and configured with storage based Point-in-time copy and full volume copy. The storage shall also support thin provisioning & de-duplication.		
21	The storage system shall be configured with GUI based management software as below: <input type="checkbox"/> Monitor and manage the storage array <input type="checkbox"/> Configuring PIT's <input type="checkbox"/> Remote Storage base replication <input type="checkbox"/> Storage front end port monitoring <input type="checkbox"/> Disk Monitoring <input type="checkbox"/> LUN management.		

	□ Storage Component replacement, etc.		
22	The Storage Array shall support storage based data replication in both synchronous and asynchronous modes.		
23	<i>The storage should be configured with 40TB (raw capacity) using FC /SAS disk & should capable to scaling up to 100TB (raw capacity). The scalability should be with 25 TB with 450/600GB GB FC / SAS disks @15K RPM & remaining 35TB with 500GB or higher capacity SATA/ FATA disks @15K RPM</i>		
24	<i>40TB RAW capacity should be configured with 450GB or higher capacity FC /SAS disk @15K RPM.</i>		
25	Vendor should factor Storage Operating System disk and Global Hot Spare disks as an additional to the RAW capacity mentioned		
26	Licenses for software (Storage Array Management, Point-in-Time Copy, Volume Copy, multipathing, thin provisioning & de-duplication software for host) should be provided as part of the solution		
27	Storage solution shall factor one hot spare disk for every 15 disk used in Storage Subsystem, unless required or other wise specified in the solution.		
28	All specifications stated are minimum required. Proposed system may have features over and above the minimum specification stated. Bidder should ensure that the performance of storage is not negatively affected for the entire duration of the contract		

1.2.2.6.2 Backup Solution

Bidders should meet the below given backup window:

Backup solution should be capable of taking data backup @25TB/ 10Hr.

In addition to that Bidder has to take backup of all Server's of State Data Centre to local Data backup (Local disk backup) in to the same Tape library. Bidder may consider D2D2T backup solution to achieve above Backup window.

The backup licenses should be asked for OS, DB and capacity based. The unit for discovery can be 10 for OS, 5 for DB and 25TB for capacity.

Bidders are free to choose backup solution components to meet above backup window, which should also include backup server hardware and backup software. Proposed backup solution should include Tape Library Latest Technology) and Disk Library to backup all the servers in the datacenter. The vendor shall factor license to ensure backup of the entire server in Data Center. Bidder should provide the required agents for RDBMS, Application & other component used in data center for backup. Backup window will remain unchanged for the entire project period.

Backup Media cost would be borne by the bidder.

Bidder has to provide the backup media to achieve the above window and cost for the same would be borne by the bidder.

DCO shall be responsible for the backup and scalability of the equipments procured by him i.e. SAN storage and servers. For collocated model where the user departments will be bringing their own hardware, it will be the user departments' responsibility to take backup and DCO will only facilitate the backup.

Tape library should be configured with minimum 100 slots for storing one month Tape backup inside the Library.

- Backup Tape Library configuration should be of latest technology and drive available in the market and should have enough slots to keep a week's data tapes inside the library.
- Fire proof cabinet

Required cartridges (pre-labeled barcodes) from the tape library OEM to be provided

Backup window calculation to be done using native data capacity to be backed up. Failure of hardware extended backup window is an exceptional situation only. Backup Media cost would be borne by the bidder.

Please mention the specifications of the solution (Tape Library and Disk Library to backup).

Disk library and Tape library should support GUI for monitoring and management

Note: Bidder should define the additional hardware features of the backup hardware that bidder is providing in the above table.

Product shall be provided with all the required licenses, software as applicable to meet the the proposed solution.

Indicative Diagram:

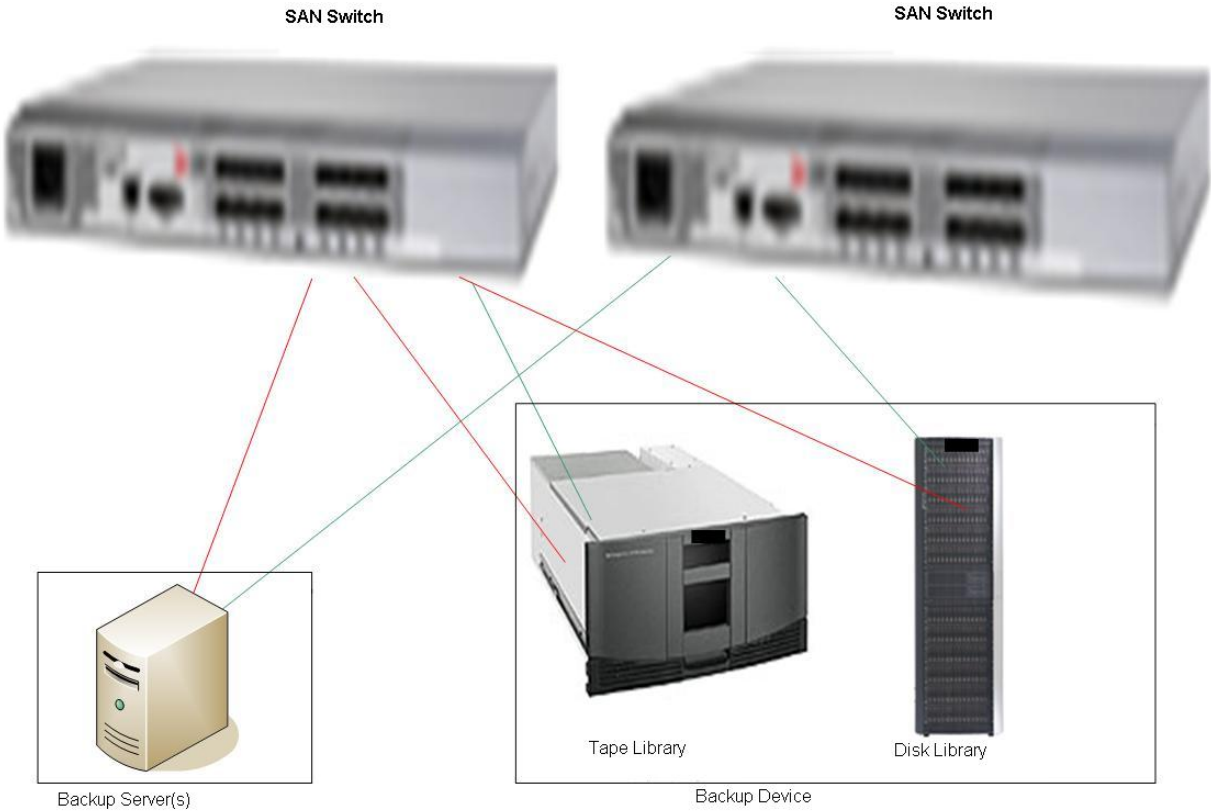

1.2.2.6.3 Backup Software

The proposed back-up software shall support the following features:

S. No.	DESCRIPTION	QTY	Pg No. where the functionality/ specification mentioned
Backup Software		01	
S. No.	Specifications	Compliance/ Deviation	
1.	Shall provide centralized and scheduled backup/restore management capabilities for most of the Popular Operating Systems: UNIX (SUN Solaris, HP-UX and IBM AIX), Linux, Windows, Vmware etc.		
2.	The Backup Software shall support open tape format.		
3.			
4.	“Shall support Disk based Backup, so as to provide High Speed Backup on to Disk/VTL, and simultaneously stage it to the Tape Device. Backup software should have capability to backup application platform like Oracle, MS-SQL, DB2, Exchange, Lotus Notes, SAP R3, etc. runs on Windows/UNIX/Linux/Vmware OS platform.”		
5.	The backup software should be able to create multiple copies of the backed up data simultaneously or after the primary backup.		
6.	Ability to support all the popular OS clusters (SUN, HP, IBM, Microsoft, Veritas and EMC, etc.), i.e. identify the nodes in the cluster as clustered nodes and backup the nodes as clustered nodes ensuring consistent data backup in case one of the nodes go down.		
7.	The backup software should support backup over SAN and LAN		
8.	Proposed the backup software should support policy based backup for full, Incremental and differential		

	backup.		
9.	Backup software must have an integrated RDBMS as the catalog database and must not use any flat file to store the backup data.		
10.	Backup software shall support free pool concepts so that media can be picked from the free pool in case of non-availability of media in the designated pools.		
11.	Backup Software shall support open file backup.		
12.	Backup software shall support High Availability configuration		
13.	In case of Multi drive backup, backup software shall offer the functionality to by pass the failed drive.		
14.	Backup solution shall support online reporting		
15.	Backup solution should be able to send messages via email and SMS		
16.	Backup software should support Bare Metal Hardware Recovery		
17.	Backup software should support large catalogue size		
18.	Backup solution shall support online reporting		
19.	Licenses for agents to be installed on relevant servers to be provided by DCO. Therefore, DCO must ensure that adequate no of such license which must be taken in consideration in technical and commercial bid.		
20.	“The proposed solution should integrate with third party VTL which has global data deduplication capabilities.”		

1.2.2.6.4 Backup Server Hardware

S.No	Description	Quantity	Pg No. where the functionality/ specification mentioned
Backup Server hardware (rackmountable)		1	
Sno.	Component	Desired Specifications	Compliance/ Deviation
1.	Make Offered	Mention Make	
2.	Model Offered	Mention Model	
3.	Certification(s) Required	OEM - ISO 9001 Manufacturer Certified on proposed OS(s)	
	Std. Compliance(s) Req.	UL, FCC & RoHS	
	Server Form Factor	Rack mountable (not a chassis based server), pl. mention server height in U	
4.	No. of CPU	2 X Quad Core	
	Speed (Mention anyone)	Min. 2.3 GHz (Intel Xeon Or AMD Opteron)	
	Cache Memory	Min. 2 MB L2 Cache	
6.	Chipset	Latest Server Chipset	
7.	RAM (Min/Scalable)	16 GB scalable to 64 GB	
	Type of RAM	DDR3/SDRAM/FB-DIMM with ECC	
8.	Hard Disk Drive(s)	4 x 146 GB	
	Type of HDD	Hot plug @ 10K SFF SAS	
	HDD Controller	Dual Channel H/W RAID Level 0,1,5	
	Cache Memory	Min. 128 MB	
9.	Network Port	Min. 4 X 1Gbps	
10.	Network Mgmt port	Required	
11.	Optical Drive	1 x DVD Drive (latest speed)	
12.	Power Supply/Cooling Fans	Hot swappable - Redundant PS / Cooling units	
13.	Slot on board	At least 2 x PCIX/PCI-e free slots.	
14.	Virtualization	Support industry standard virtualization solution	
15.	Management	a. OS independent hardware health	

		status b. Standards based OEM remote server management suite/sw		
	Keyboard & Mouse	Virtual KVM based remote control		
16.	Connectivity to SAN (indicative, however should change the quantity of FC ports)	a. Fiber Channel 2 x dual port 4Gbps		
		b. SAN HBAs should be connected on separate slots for high throughput and redundancy requirement		
		c. HBA should support storage subsystems and servers of leading manufactures like EMC, Hitachi, HP, IBM, SUN etc		
		d. HBA load balancing / Multi-path software should be provided as part of solution		
		e. HBA card should support the the above mentioned hardware		
17.	Other component	The bidder has to consider and account for all other components, if any which are required to provide the solution (mention the list of such components)		
18.	Any other feature which the bidder wish to mention here	Please mention here:1.		
		2.		
		3.		

Note: Bidder has to ensure Backup window as 25TB/10hrs, hence he can suggest better hardware, software to meet the requirement. (Above is indicative)

1.2.2.6.5 OS Software for Backup Server

S.No	Description		Qty License	Pg No. where the functionality/ specification mentioned
OS Software for Backup Server				
1.	Operating System(s) (Software should be of latest version with license, req. media, docs for entire project period Etc)	Bidder has to choose appropriate Enterprise OS with adequate no. of licenses based on processor / core as per the hardware mentioned above with updates, patches, OEM support pack etc. valid for a project period.	1	

1.2.2.6.6 SAN Switch (Quantity – 2)

S.No	DESCRIPTION		QTY	Pg No. where the functionality/ specification mentioned
Hardware Features for SAN Switch			1 + 1	
S.No	Desired Specifications		Compliance/ Deviation	
1.	Make Offered	Mention Make		
2.	Model Offered	Mention Model		
3.	Certification(s) Required	OEM - ISO 9001 Manufacturer		
4.	The SAN Switch solution should be highly available with no single point of failure. All the patch cords, cables and connectivity channels should be provided by bidder as part of the solution. It is advised the patch cords to be provided of same make.			
5.	Switch should support non disruptive Micro code/Firmware upgrade			
6.	Bidder should provision for a highly available fiber channel switch architecture with no single point of failure			
7.	Switch shall support minimum 48 ports expandable to 64 ports X 4Gbps (with port activation licenses). However bidder has to ensure sufficient number of ports of 4Gbps looking to the solution as of now including backup solution and 40% future expandability. (The bidder has to provide such adequate number of ports on SAN switch to meet the solution requirements)			
8.	The switch shall support Port zoning and LUN zoning, GUI management software			
9.	The SAN switch should have capability to interface with HBA of different makes and model from multiple OEM, supporting multiple Operating Systems, including, but not limited to HP-UX, IBM AIX, Linux, MS-Window, Sun Solaris etc. The SAN switch should support all leading			

	SAN disk array and tape libraries including, but not limited to, EMC, Hitachi, HP, IBM, Sun, NetApp etc.		
10.	Product shall be provided with all the required licenses, software, required accessories, cable etc. as applicable to meet all the above mentioned specification and hence the proposed solution.		
11.	HBA Cables shall be provided by the Bidder to meet the solution requirement		
12.	Any other feature which the bidder wish to mention here	Please mention here: 1.	
		2.	
		3.	

1.2.2.7 Directory Services

This active directory deployment shall be the source of defining centralized authentication mechanism for the users. This user directory shall enable easy manageability that is creation, modification and deletion of user records. This is being used for identification, authentication, authorization and implementing the identity security policies required. This shall help in deploying required group policies & software restriction policies for efficient administration & management by associating policies around security, management etc.

Many setups have multiple directory services that they must manage, such as one for sending e-mail, one for managing user accounts etc. The complexity of administering and using multiple accounts has a negative effect on the productivity of everyone involved. It is planned that, the addition IT infrastructure services being provisioned as part of the common state infrastructure like Proxy etc. shall use this active directory for the centralized authentication requirement. This directory will be designed for fulfilling requirements of SDC. The bidder shall carry out the following Directory server deployment tasks:

- Create the Directory Server Design including deployment architecture
- Create Directory naming convention for users and computers
- Implement the Directory Servers as per the design and deployment plan
- Implement organizational unit structure
- Create user accounts
- Configure and test sample identity Security policies
- Documentation of Directory implementation process including design documents

1.2.2.7.1 Directory Service – Software

S. No.	DESCRIPTION	QTY	Pg No. where the functionality/ specification mentioned
Directory service Software Specifications		1 + 1	
S.No.	Desired Specifications	Compliance/ Deviation	
1.	Directory Services should be integrated LDAP compliant directory services to store information about users, computers, and network resources, file shares, printers and making the resources accessible to users and applications		
2.	Support for integrated LDAP compliant directory		

	services to record information for users, and system resources		
3.	Should support integrated authentication mechanism across operating system, messaging services		
4.	Should support directory services for ease of management and administration/replication		
5.	Should support security features, such as Kerberos public key infrastructure (PKI), etc		
6.	Should provide support for X.500 naming standards		
7.	Should support Kerberos for logon and authentication		
8.	Should support that user account creation/deletion rights within a group or groups can be delegated to any nominated user		
9.	Product shall be provided with all the required licenses, software as applicable to meet all the above mentioned specification and hence the proposed solution.		
10.	Client licenses if required would be 50 in number		

1.2.2.7.2 DNS, DHCP - Software specifications :

S.No.	DESCRIPTION	QTY	Pg No. where the functionality/ specification mentioned
	DNS, DHCP Software	1 + 1	
S.No.	Specifications	Compliance/ Deviation	
	Software features		
1.	Support integration with other network services like DHCP, directory, etc.		
2.	Should support DNS forwarders e.g. forwarding based on a DNS Domain name in the query.		

3.	Should allow clients to dynamically update resource records secure and non-secure		
4.	Should Support incremental zone transfer between servers		
5.	Should provide security features like access control list		
6.	Should support several new resource record (RR) types like service location (SRV), etc.		
7.	Should support Round robin on all resource record (RR) types		
8.	Support integration with other network services like DHCP, directory, etc.		
9.	Product shall be provided with all the required licenses, software as applicable to meet all the above mentioned specification and hence the proposed solution.		

1.2.2.7.3 Directory Service, DNS, DHCP – Hardware (Blade)

S.No.	DESCRIPTION		QTY	Pg No. where the functionality/ specification mentioned
Directory Service, DNS, DHCP- Hardware (Blade)			1 + 1	
S.no.	Component	Desired Specifications	Compliance / Deviation	
1.	Make Offered	Mention Make		
2.	Model Offered	Mention Model		
3.	Certification(s) Required	OEM - ISO 9001 Manufacturer Certified on proposed OS(s)		
	Std. Compliance(s) Req.	UL, FCC & RoHS		
	Server Form Factor	Blade to be inserted into above blade enclosure		
4.	No. of CPU	2 X Quad Core		
	Speed (Mention anyone)	Min. 2.3 GHz (Intel Xeon Or AMD Opteron)		
	Cache Memory	Min. 2 MB L2 Cache		
5.	Chipset	Latest Server Chipset		
6.	RAM (Min/Scalable)	16 GB scalable to 64 GB		
	Type of RAM	DDR3/SDRAM/FB-DIMM with ECC		
7.	Hard Disk Drive(s)	2 x 146 GB		
	Type of HDD	@ 10K SFF SAS		
	HDD Controller	Dual Channel H/W RAID Level 0,1		
8.	Network Port	Min. 2 X 1 Gigabit NIC ports per blade server		
9.	Network Mgmt port	Required		
10.	Power	Remote Power Management		
11.	Slot on board	At least 2 x PCIX/PCI-e free slots.		
12.	Virtualization	Support industry standard virtualization solution		

14.	Management	a. OS independent hardware health status b. Standards based OEM remote server management suite/sw		
	Keyboard & Mouse	Virtual KVM based remote control		
15.	Enclosure	To fit in Blade Chasis/ Enclosure as specified (Section 1.2.1.2)		
16.	HBA Port	Blade should be provided with 4 Gbps HBA port		
17.	Any other feature which the bidder wish to mention here	Please mention here: 1.		
		2.		
		3.		

Note: Bidder should define the hardware features of the directory services hardware that bidder is providing. Product shall be provided with all the required licenses, software as applicable to meet the the proposed solution.

1.2.2.7.4 Operating System Software for Directory Service, DNS and DHCP

S.No	Description	Quantity License	Pg No. where the functionality/ specification mentioned
Software for Directory Service OS			
1.	Operating System(s) (Software should be of latest version with license, req. media, docs for entire project period Etc)	Bidder has to choose appropriate Enterprise OS with adequate no. of licenses as per the hardware mentioned above with updates, patches, OEM support pack etc. valid for a project period. (Mention OS)	2

1.2.2.8 Anti-Virus Solution (with 50 user licenses)

1.2.2.8.1 Antivirus Software specifications

S.No.	DESCRIPTION	QTY	Pg No. where the functionality/ specification mentioned
Anti-Virus Solution - Software Specifications		1	
S.No.	Desired Specifications	Compliance / Deviation	
Software features			
1.	Should restrict e-mail bound Virus attacks in the real time without compromising the performance of the system		
2.	Should be capable of providing multiple layer of defense		
3.	Should have installation support on gateway / Mailing server.		
4.	Should be capable of detecting and cleaning virus infected attachments as well		
5.	Should support scanning for ZIP, RAR compressed files, and TAR archive files		
6.	Should support online update, where by most product upgrades and patches can be performed without bringing messaging server off-line.		
7.	Should use multiple scan engines during the scanning process		
8.	Should support in-memory scanning as to minimum disk I/O		
9.	Should support Multi-threaded scanning		
10.	Should support scanning of a single mailbox or a one off scan.		
11.	Should support scanning by file type for attachments		
12.	Should support scanning of nested compressed files		
13.	Should be capable of specifying the logic with which scan engines are applied; such as the most recently updated scan engine should scan all emails etc		
14.	Should support heuristic scanning to allow rule-based		

	detection of unknown viruses		
15.	Updates to the scan engines should be automated and should not require manual intervention		
16.	Updates should not cause queuing or rejection of email		
17.	Updates should be capable of being rolled back in case required		
18.	Should support content filtering based on sender or domain filtering		
19.	Should provide content filtering for message body and subject line, blocking messages that contain keywords for inappropriate content		
20.	File filtering should be supported by the proposed solution; file filtering should be based on true file type.		
21.	Common solution for anti-spy ware and anti-virus infections; and anti-virus and anti-spy ware solution should have a common web based management console.		
22.	Should support various types of reporting formats such as CSV, HTML and text files		
23.	Should be capable of being managed by a central management station		
24.	Should support client lockdown feature for preventing desktop users from changing real-time settings		
25.	Should support insertion of disclaimers to message bodies		
26.	Product shall be provided with all the required licenses, software as applicable to meet all the above mentioned specification and hence the proposed solution.		
27.	The bidder has to account for the following client antivirus software : 1. for all servers being installed in the SDC 2. for all other computing devices such as desktops, laptops etc.		
28.	The bidder would ensure client antivirus subscription valid for the period of project, therefore, no. of client antivirus software/solution, there subscription should work for the project period with out any expiration of services.		

29.	The antivirus solution should be available on cross platform i.e. Windows, RHEL etc. available in the SDC		
30.	Anti virus software should be provided with 50 user licenses.		

1.2.2.8.2 Anti-Virus Solution – Hardware

S.No	Description	Qty	Pg No. where the functionality/ specification mentioned
Anti-Virus Solution – Hardware – Blade Server		1	
S.No.	Component	Desired Specifications	Compliance/ Deviation
1.	Make Offered	Mention Make	
2.	Model Offered	Mention Model	
3.	Certification(s) Required	OEM - ISO 9001 Manufacturer Certified on proposed OS(s)	
	Std. Compliance(s)	UL, FCC & RoHS	
	Server Form Factor	Rack mountable (not a chassis based server), pl. mention server height in U	
5.	No. of CPU	2 X Quad Core	
	Speed (Mention anyone)	Min. 2.3 GHz (Intel Xeon Or AMD Opteron)	
	Cache Memory	Min. 2 MB L2 Cache	
6.	Chipset	Latest Server Chipset	
7.	RAM (Min/Scalable)	16 GB scalable to 64 GB	
	Type of RAM	DDR3/SDRAM/FB-DIMM with ECC	
8.	Hard Disk Drive(s)	4 x 146 GB scalable up to min. 6 such HDD	
	Type of HDD	Hot plug @ 10K SFF SAS	
	HDD Controller	Dual Channel H/W RAID Level 0,1	
9.	Network Port	Min. 2 X 1Gbps	
10.	Network Mgmt port	Required	
11.	Optical Drive	1 x DVD Drive(latest speed)	
12.	Power Supply/Cooling Fans	Hot swappable - Redundant PS / Cooling units	
13.	Slot on board	At least 2 x PCIX/PCIE free slots	
14.	Virtualization	Support industry standard	

		virtualization solution		
15.	Management	a. OS independent hardware health status b. Standards based OEM remote server management suite/sw		
	Keyboard & Mouse	Virtual KVM based remote control		
16.	Blade Chassis/Enclosure: (Section 1.2.1.2)			
17.	Operating System(s) (Software should be of latest version with license, req. media, docs for entire project period Etc)	Bidder has to choose appropriate Enterprise OS with adequate no. of licenses as per the hardware mentioned above with updates, patches, OEM support pack etc. valid for a project period. (Mention OS)		
18.	Any other feature which the bidder wish to mention here	Please mention here: 1.		
		2.		
		3.		

Note: The above hardware for Anit-Virus Solution is indicative. However bidder has to provide appropriate hardware as per the solution proposed.

For all the hosting models, the SDC will be responsible for providing free of cost Power, Cooling and Space. Monitoring through EMS and Anti Virus support will be free for the entire DC space and also the responsibility of the DCO through the initially procured licenses. Additional licenses if required would be provided by the State/Line Department but EMS monitoring and Antivirus support would be free.

1.2.2.8.3 OS Software Licenses for Antivirus Servers

S.No	Description	Quantity License	Pg No. where the functionality/ specification mentioned
OS Software for AntivirusServer			
1.	Operating System(s) (Software should be of latest version with license, req. media, docs for entire project period Etc)	Bidder has to choose appropriate Enterprise OS with adequate no. of licenses as per the hardware mentioned above with updates, patches, OEM support pack etc. valid for a project period. (Mention OS)	1

1.2.2.9 Management Solution

1.2.2.9.1 Management Solution - Software Specification

S.No	DESCRIPTION	QTY	Pg No. where the functionality/ specification mentioned
Management Server – Software		1	
S.No.	Desired Specifications	Compliance/ Deviation	
	Features		
1.	Bidder should propose the software for the security and network management solution for the state Datacenter which should be integrated with the EMS solution.		
2.	Product shall be provided with all the required licenses, software as applicable to meet all the above mentioned specification and hence the proposed solution.		

1.2.2.9.2 Management Servers – Hardware

S.No.	DESCRIPTION	QTY	Pg No. where the functionality/ specification mentioned
Management Server		1	
S.No.	Component	Desired Specifications	Compliance/ Deviation
1.	Make Offered	Mention Make	
2.	Model Offered	Mention Model	
3.	Certification(s) Req.	OEM - ISO 9001 Manufacturer	
		Certified on proposed OS(s)	
	Std. Compliance(s)	UL, FCC & RoHS	
4.	Server Form Factor	Rack mountable(not a chassis based server),, pl. mention server height in U	

5.	No. of CPU	2 X Quad Core		
	Speed (Mention anyone)	Min. 2.3 GHz (Intel Xeon Or AMD Opteron)		
	Cache Memory	Min. 2 MB L2 Cache		
6.	Chipset	Latest Server Chipset		
7.	RAM (Min/Scalable)	16 GB scalable to 64 GB		
	Type of RAM	DDR3/SDRAM/FB-DIMM with ECC		
8.	Hard Disk Drive(s)	2 x 146 GB scalable to 6 HDD		
	Type of HDD	Hot plug @ 10K SFF SAS		
	HDD Controller	Dual Channel H/W RAID Level 0,1		
9.	Network Port	Min. 4X1Gbps		
10.	Network Mgmt port	Required		
11.	Optical Drive	1 x DVD Drive(latest speed)		
12.	Power Supply/Cooling Fans	Hot swappable - Redundant PS / Cooling units		
13.	Slot on board	At least 2 x PCIX/PCIEfree slots		
14.	Virtualization	Support industry standard virtualization solution		
15.	Management	a. OS independent hardware health status b. Standards based OEM remote server management suite/sw		
16.	Management	OS independent hardware health status		
	Keyboard & Mouse	Virtual KVM based remote control		
17.	Other	Product shall be provided with all the required licenses, software as applicable to meet the the proposed solution.		
18.	Any other feature which the bidder wish to mention here	Please mention here: 1.		
		2.		
		3.		

Note:

- Apart from the above feature please define all the hardware features of the Management server that bidder is providing.
- Product shall be provided with all the required licenses, software as applicable to meet the the proposed solution.

- Bidder has to ensure the requirement of solution proposed, hence bidder can suggest better hardware, software to meet the requirement. (Above is indicative)

1.2.2.9.3 Software Licenses for Management Servers

S.No	Description	Quantity License	Pg No. where the functionality/ specification mentioned
Software for Management Server			
1.	Operating System(s) (Software should be of latest version with license, req. media, docs for entire project period Etc)	Bidder has to choose appropriate Enterprise OS with adequate no. of licenses as per the hardware mentioned above with updates, patches, OEM support pack etc. valid for a project period. (Mention OS)	1

1.2.2.10 IP KVM

S. No.	DESCRIPTION	QTY	Pg No. where the functionality/ specification mentioned
IP KVM		5	
S.No.	Desired Specifications	Compliance/ Deviation	
Hardware features			
1.	Form Factor - It should be rack-mountable		
2.	Supported servers – Min. 256 in a two-level cascade		
3.	Minimum Ports : 16 x 10/100 Mbps-RJ45 server ports 1 x 15 Pin SVGA/XGA 1 x PS/2 or USB 2.0 Mouse 1 x PS/2 or USB 2.0 Keyboard		
4.	It should support min. 1 LAN (Local), min. 3 WAN(Remote) access		
5.	It should support min. 4 number of simultaneous users		
6.	<i>The KVM switch should be SNMP Trap Support enabled. It should be operable from remote locations.</i>		
7.	It should have 15 inch TFT monitor and a movable front panel		
8.	It should support multiple operating system		
9.	It should have serial device switching capabilities		
10.	It should have dual power with fail over and built-in surge protection		
11.	It should support multi-user access and collaboration		
12.	It should have support for blade server and rack mounted server of different brands/OEM		
13.	It should include required software (server / client), cables, and other accessories		
14.	It should support password protection for restricted access		
15.	Any other feature which The	Please mention	

	bidder wish to Mention here	here: 1.		
		2.		
		3.		

Adequate number of desktops,laptops, multifunction device which are required to make the solution work would have to be included by the bidder.

1.2.3 Technical Specifications – IT Network Components

Following are different types of equipment configurations that shall be required for the State Data Center (SDC).

Items and the configurations categorically mentioned below are the configurations required for the Implementation of SDC network and security architecture. Any thing proposed by vendor over and above the minimum required specs are acceptable; however, anything that is below the minimum mentioned requirement even in a single specification may get the product disqualified.

The vendor has to include this as the part of the technical proposal with the make and model numbers. The requirement of various components may be in phases.

The solution elements given by the bidder should comply with the specifications of various devices mentioned below. Bidder shall have the responsibility to make to solution work and hence any additional component might be required for the solution to work shall be provided by the bidder at their own cost and within the implementation schedule. Also, the migration of IPv4 to IPv6 if required by the state in future shall be done by the bidder at additional cost which shall be out of scope of this RFP.

As per recommended and best practices, the components shall preferably be appliance based (wherever applicable) and the intranet and internet firewalls shall be from different OEMs.

Provisioning of the internet bandwidth is the responsibility of the State government. DCO will only liaison with the ISPs..

The bandwidth details are as under:

Denomination	=	2x10 Mbps Internet bandwidth
Ratio	=	1:1
End point type	=	SDC, RJ45

The DCO get the payment shall be made as per actual upon submission of periodical bills.

Manuals for configuring of switches, routers, firewall, IPS etc shall be provided by the selected bidder.

**1.2.3.1 LAN Switch – Core
Hardware Specification (Quantity - 2)**

The suggested core switch should have features as under:

S.No	Description	Quantity	
1.	LAN Switch – Core	1+1	
S.No.	Specifications	Compliance Yes/No	Page Reference in product data sheet
	Hardware Features		
1.	<ul style="list-style-type: none"> • High back plane speed (700 Gbps or more) 1.1 19” rack mountable 1.2 Active switching bandwidth should be 700 Gbps or more with offered modules. 1.3 <i>The forwarding rate should be 300 Mpps for IPv6</i> 1.4 Should have at least 48 x 10/100/1000 BaseT auto sensing ports with Line rate forwarding performance 1.5 Min 1 x 48 SFP Gig Fiber ports with fiber modules (SX) 1.6 The switch should have minimum of 9 slots. 1.7 Should be a single chassis 1.8 Optional 10 g interface support. 1.9 Multicast support (PIM SM & DM and IGMP Snooping) 1.10 Wire speed performance on each offered interfaces. 1.11 The switch should provide IPV4 and IPV6 without any performance degradation 		
2.	<ul style="list-style-type: none"> • Should have redundancy at various levels: 2.1 Should have redundant Power Supply, preferably single power supply should be sufficient to provide fully loaded chassis. 2.2 Should support redundant Switching engine. 		

	<p>With failure of one switching engine, there should be no performance degradation.</p> <p>In the event of failure of one switching engine, forwarding should not stop & failover from one engine to other should be state full.</p>		
3.	<ul style="list-style-type: none"> • Layer 2 Features 4.1 Layer 2 switch ports and VLAN trunks 4.2 IEEE 802.1Q VLAN encapsulation 4.3 Support for at least 4000 VLANs. 4.4 802.1s 4.5 802.1w 4.6 Port trunking capability. 4.7 Port mirroring capability 4.8 Support for 50,000 or more MAC addresses 		
4.	<ul style="list-style-type: none"> • Layer 3 features 5.1 VRRP/HSRP 5.2 Static IP routing 5.3 IP routing protocols 5.4 Open Shortest Path First 5.5 Routing Information Protocol 5.6 IP Version 6 support. 5.7 Should support DHCP 		
5.	<ul style="list-style-type: none"> • Standards 6.1 Ethernet : IEEE 802.3, 10BASE-T 6.2 Fast Ethernet : IEEE 802.3u, 100BASE-TX 6.3 Gigabit Ethernet: IEEE 802.3z, 802.3ab 6.4 IEEE 802.1D Spanning-Tree Protocol 6.5 IEEE 802.1w rapid reconfiguration of spanning tree 6.6 IEEE 802.1s multiple VLAN instances of spanning tree 6.7 IEEE 802.1p class-of-service (CoS) prioritization 6.8 IEEE 802.1Q VLAN encapsulation 6.9 IEEE 802.3af 6.10 IEEE 802.3ad 		

	<p>6.11 IEEE 802.1x user authentication</p> <p>6.12 1000BASE-X (small form-factor pluggable)</p> <p>6.13 1000BASE-X (GBIC) (Support for SX,LX,ZX)</p>		
6.	<ul style="list-style-type: none"> • High Availability <p>7.1 Shall support Redundant Power supply</p> <p>7.2 Shall support On-line insertion and removal for cards, Power Supply and Fan tray.</p> <p>7.3 Shall support multiple storage of multiple images and configurations.</p>		
7.	<ul style="list-style-type: none"> • QOS support • Rate limiting based on source/destination IP /MAC, L4 TCP/UDP 		
8.	<ul style="list-style-type: none"> • Security Features <p>9.1 AAA support using RADIUS and/ or TACACS.</p> <p>9.2 Unicast MAC filtering</p> <p>9.3 IP Access list support.</p> <p>9.4 Multiple privilege level authentication for console and telnet access.</p> <p>9.5 Shall support per port broadcast, multicast and unicast storm control.</p>		
9.	<ul style="list-style-type: none"> • Management <p>10.1 Shall have support for Web based management, CLI, Telnet and SNMPv1, 2c,v3</p> <p>10.2 Shall support SSH</p> <p>10.3 Should support multiple levels of administration roles to manage and monitor the device.</p> <p>10.4 Should support Network Time Protocol.</p> <p>10.5 Should be able to send and receive Syslog and SNMP traps from devices.</p>		
10.	"Min 16 Nos of 10 Gig ports".		
11.	"The Switch should be EAL certified"		

1.2.3.2 LAN Switch – Access

Hardware Specification (Quantity - 6)

S.No.	Description	Quantity	
1.	LAN Switch – Access	6	
S.No.	Specifications	Compliance Yes/No	Page Reference in product data sheet
Hardware Features			
1.	<ul style="list-style-type: none"> • Switch Architecture 1.1 19” rack mountable 1.2 24 X 10/100/1000 port switch and 2 X 10 Gig ports 1.3 Port mirroring capability. 1.4 Multicast support (PIM, IGMP snooping, SM and DM) 		
2.	<ul style="list-style-type: none"> • Switch Throughput 2.1 88 Gbps or more forwarding bandwidth. 		
3.	<ul style="list-style-type: none"> • Protocol and standards support 3.1 IPv6 support from day 1 3.2 Ethernet : IEEE 802.3, 10BASE-T 3.3 Fast Ethernet : IEEE 802.3u, 100BASE-TX 3.4 Gigabit Ethernet: IEEE 802.3z, 802.3ab 3.5 IEEE 802.1D Spanning-Tree Protocol 3.6 IEEE 802.1w rapid reconfiguration of spanning tree 3.7 IEEE 802.1s multiple VLAN instances of spanning tree 3.8 IEEE 802.1Q VLAN encapsulation 3.9 IEEE 802.3ad 3.10 IEEE 802.1x user authentication 		
4.	<ul style="list-style-type: none"> • QoS support 		
5.	<ul style="list-style-type: none"> • Manageability 		

	5.1 Built in Web based management support 5.2 Built in Console port 5.3 SNMP 5.4 Should support auto-sensing and auto-negotiation on each non-GBIC ports. 5.5 Network Timing Protocol (NTP).		
6.	<ul style="list-style-type: none"> • Security Features supported 6.1 TACACS+ and RADIUS support. 6.2 MAC-based port-level security prevents unauthorized stations from accessing the switch. 6.3 Private Vlan or equivalent feature		
7.	<ul style="list-style-type: none"> • Switch Architecture: 1.5 “Switch should support stacking”, 1.6 “Switch should have internal redundant power supply” • Protocol and Standard Support: “Static routing, RIP, OSPF, RIPng, OSPFv3.” “The Switch should be EAL certified”.		

1.2.3.3 INTERNET Router

Hardware Specification (Quantity - 2)

S.No	Description	Quantity	
1.	Internet Router	1+1	
S.No	Specification	Compliance Yes/ No	Page Reference in product data sheet
	Hardware Features		
1.	<ul style="list-style-type: none"> • Router Architecture 1.1 19" rack Mountable 1.2 Modular chasis. 		
2.	<ul style="list-style-type: none"> • High Availability Requirements 2.1 VRRP/ HSRP 2.2 High Mean Time between Failure values should be available to ensure long life of router hardware. 2.3 The router should be capable of booting from a remote node or external flash memory, where the router image is present. 2.4 The Router should have internal redundant power supply 2.5 Support for hot swappable modules 		
3.	<ul style="list-style-type: none"> • Miscellaneous Hardware Requirements 3.1 Sufficient RAM must be available for proper router operation to keep IGP and EGP routes. 3.2 Extensive debugging capabilities to assist in hardware problem resolution. 		
4.	<ul style="list-style-type: none"> • Interface Modules have/ support 4.1 4.2 8 X 10/100/1000 baseTX ethernet 		

	<p>interfaces for LAN and WAN</p> <p>4.3 All the Serial Ports should be Flex-Configured for RS-232/V.35 interfaces.</p> <p>4.4 Shall be able to support variety of other interfaces.</p>		
5.	<ul style="list-style-type: none"> • • Performance requirement: The router should have a minimum of 1 Mpps throughput The router should have minimum 700 Mbps of IPSEC performance 		
6.	<ul style="list-style-type: none"> • Router Software Features <p>6.1 Should support the standard routing protocols with QoS.</p>		
7.	<ul style="list-style-type: none"> • Router Functional Requirements <p>7.1 Network address translation.</p>		
8.	<p>8.1</p> <ul style="list-style-type: none"> • IP Routing Protocols <p>8.1 RIP v1 and v2</p> <p>8.2 OSPF v2 and v3</p> <p>8.3 BGP</p> <p>8.4 Policy Routing.</p> <p>8.5 Static Routing Protocols</p> <p>8.6 DHCPv6</p> <p>8.7 IPV6 ICMP</p> <p>8.8 IPv6 QoS</p> <p>8.9 IPv6 Multicast</p> <p>8.10 MLD</p> <p>VPN</p>		
9.	<ul style="list-style-type: none"> • Protocols <p>10.1 PPP</p> <p>10.2 Multilink PPP</p>		
10.	<ul style="list-style-type: none"> • Multicasting and QoS (PQ, cRTP, LFI, WRED) 		
11.	<ul style="list-style-type: none"> • Accounting <p>12.1 Network Time Protocol.</p>		

	<p>12.2 Packet & Byte Counts.</p> <p>12.3 Start Time Stamp & End Time Stamps.</p> <p>12.4 Input & Output interface ports.</p> <p>12.5 Type of service, TCP Flags & Protocol.</p> <p>12.6 Source & Destination IP addresses.</p> <p>12.7 Source & Destination TCP/ UDP Addresses</p>		
12.	<ul style="list-style-type: none"> • Security <p>13.1 Support for Standard Access Lists and Extended Access Lists to provide supervision and control.</p> <p>13.2 Controlled SNMP Access.</p> <p>13.3 Control SNMP access through the use of SNMP with authentication.</p> <p>13.4 Multiple Privilege Levels.</p> <p>13.5 Support for Remote Authentication Dial-In User Service (RADIUS) and AAA.</p> <p>13.6 Support GRE and IPSEC based encryption</p>		
13.	<ul style="list-style-type: none"> • Other required features <p>14.1 Ethernet Interface of the Router should support 802.1Q</p> <p>14.2 Support for additional Ethernet Interface card</p> <p>14.3 Should have automatic route optimization and load distribution over multiple service provider networks.</p>		
14.	<ul style="list-style-type: none"> • Management Requirements <p>15.1 Telnet and SSH</p> <p>15.2 SNMP</p> <p>15.3 Shall have Console port for local management.</p> <p>15.4 Configuration replacement and roll back functionality</p> <p>15.5 Preplanned reboot</p>		
15.	Security: "Support DOS prevention and CGNAT/		

	Dual Stack”		
16.	“The Switch should be EAL certified”		

1.2.3.4 Firewall Internet

Hardware Specification (Quantity - 2)

S.No	Description	Qty	Pg No. where the functionality/ specification mentioned
Firewall – Internet		1+1	
S.No	Specification	Compliance /Deviation	
1.	Make Offered	Mention Make	
2.	Model Offered	Mention Model	
3.	<ul style="list-style-type: none"> • Hardware Architecture <ul style="list-style-type: none"> ▪ Modular chassis ▪ 19” rack mountable ▪ ▪ Shall Support At least 6 zones or more physically isolated zones from each other @ 10/100/1000Mbps and should have 2 x 10 Gig interfaces ▪ Statefull 		
4.	<ul style="list-style-type: none"> • Performance <ul style="list-style-type: none"> ▪ The firewall throughput performance should be at least 5Gbps or more ▪ ▪ Should support 3DES/AES VPN Throughput Up to 1.2 Gbps ▪ ▪ The firewall should provide at least 4,00,000 or more concurrent connections ▪ Should provide at least 26,000 connections per second or more. ▪ Should support 802.1Q trunking and at least 50 VLANs. ▪ ▪ Should support integration with AAA 		

	<p>server</p> <ul style="list-style-type: none"> ▪ ▪ Should have Application inspection for standard applications like SSHv2,, FTP, HTTP/HTTPS, ICMP, TCP, ▪ Should support inbuilt support for IPSEC VPNs with DES/ 3DES and AES support. ▪ Firewall should support MD-5 and SHA-1 authentication 		
5.	<ul style="list-style-type: none"> • Firewalling at layer 2 and layer 3 of the OSI layer. <ul style="list-style-type: none"> ▪ Static route, RIPv2, OSPF for routing ▪ NAT and Port Address Translation feature ▪ Should support IPv4 and IPv6. ▪ Optional support to be able to detect, respond to and report any unauthorized activity. 		
6.	<ul style="list-style-type: none"> • Firewall features shall include: <ul style="list-style-type: none"> ▪ ▪ ▪ ▪ ▪ Application/Protocol Inspection Engines: <ul style="list-style-type: none"> ▪ L2 transparent firewalling ▪ Advanced HTTP Inspection Engine ▪ Time-based ACLs or equivalent 		
7.	<ul style="list-style-type: none"> • VPN feature shall support: <ul style="list-style-type: none"> ▪ Support for n-tiered X.509 certificate chaining ▪ Manual X.509 certificate enrollment (PKCS 10/7 support) 		
8.	<ul style="list-style-type: none"> • <ul style="list-style-type: none"> ▪ ▪ ▪ ▪ 		

9.	<ul style="list-style-type: none"> High Availability 		
10.	<ul style="list-style-type: none"> Management <ul style="list-style-type: none"> Embedded web based configuration / management support. Should have Management access through console, SSH and GUI for managing the firewall. Should have the capability of restricting the access through the Console and out-of-band management interface to protect the devices from local threats. 		
11.	Product shall be provided with all the required licenses, software, management servers (Ref: 1.3.15) as applicable to meet all the above mentioned specification.		
12.	“Firewall should be ICASA/NSS/EAL certified.”		

1.2.3.5 Intrusion Prevention System - Internet Hardware Specifications (Quantity - 2)

S.No.	Description	Quantity	
1.	Intrusion Prevention System for Internet	1+1	
S.No	Specification	Compliance Yes/ No	Page Reference in product data sheet
	Hardware Features		
1.	<ul style="list-style-type: none"> The IPS should be appliance based and should have the following Interfaces <ul style="list-style-type: none"> 1.1 “The IPS should have minimum of 2 pairs of 10/100/1000 ports to support up to 4 inline protected segment support.” 		

	<p>1.2 1 Dedicated Management port</p> <p>1.3 “2X 10 Gig populated.”</p>		
2.	<ul style="list-style-type: none"> • Performance and Availability <p>2.1 The IPS device should provide an overall throughput of at least 1 gbps or more</p>		
3.	<ul style="list-style-type: none"> • Attack Detection Techniques <p>3.1 The IPS System should have the following attack detection techniques</p> <p>3.2 Vendors Signature Database of at least 1000 signatures.</p> <p>3.3 Shall be able to support user defined signatures.</p> <p>3.4 Zero day attack protection using protocol and traffic behavior analysis.</p> <p>3.5 Backdoor Detection</p> <p>3.6 DoS/ DDoS / SYN-flood/ TCP-flood /UDP-flood</p> <p>3.7 Monitoring of protocols such as TCP/IP, ICMP, FTP etc.</p>		
4.	<ul style="list-style-type: none"> • Action on Attacks <p>4.1 The IPS system should be able to do the following in the event of detecting an attack:</p> <p>4.1.1 Block/Drop/Terminate attacks in real time without logging.</p> <p>4.1.2 Block/Drop/Terminate attacks in real time and log.</p> <p>4.1.3 Reset connections without logging.</p> <p>4.1.4 Reset connections and log.</p> <p>4.1.5 None (Log only)</p>		
5.	<ul style="list-style-type: none"> • Other Capabilities <p>5.1 Should be capable of handling IPS evasion techniques like fragmentation and TCP reassembly etc.</p> <p>5.2 Shall be able to support user defined signatures, “Shall be able to perform</p>		

	<p>application based inspection.”</p> <p>5.3 Shall be able to support automatic signature updation from the OEM over the internet using a secure communication mechanism in the case of emergencies.</p> <p>5.4 Default security Policy.</p>		
6.	<ul style="list-style-type: none"> • High Availability <p>6.1</p> <p>6.2 “The device should support internal redundant power supply”</p> <p>6.3 It should support either active/passive or active/active</p>		
7.	<ul style="list-style-type: none"> • Deployment Modes <p>7.1 The IPS should be deployable in Bridge/Transparent mode.</p> <p>7.2 promiscuous / Inline mode</p>		
8.	<ul style="list-style-type: none"> • Management and Monitoring Capabilities <p>8.1 The IPS Systems should have a Management Console and remote telnet, SSH and Web capabilities for basic configuration of the device</p> <p>8.2 The IPS should have a dedicated port for Out-of-Band Management and should not use any traffic ports for the management purpose</p> <p>8.3</p> <p>8.4</p> <p>8.5</p> <p>8.6 The system should be able to support log file, Syslog/SDEE and snmp.</p> <p>8.7 Shall support role based administration for various administrator and user levels.</p> <p>8.8 “IPS should be ICASA/NSS/ EAL certified”</p>		
9.	<ul style="list-style-type: none"> • Product shall be provided with all the required licenses, management server software as applicable to meet all the 		

	above mentioned specification & proposal.		
--	--	--	--

1.2.3.6 End Point Protection for Servers and PCs (HIDS/ HIPS)

Bidder has to come up with number of licenses required and provide the same.

S.No	Description	Quantity	
	End Point Protection for Servers and PC's in the SDC (HIDS/ HIPS)	For all servers and PCs supplied by DCO	
S.No	Specification	Compliance Yes/ No	Page Ref in product data sheet
	Features		
1.	<ul style="list-style-type: none"> • Exploit Prevention <p>1.1 It should be able to Control applications, services and programs to only allow “good” behavior. This behavior-based, proactive functionality protects against day-zero threats. Buffer Overflow prevention should be related to this functionality also.</p> <p>1.2 It should provide broad default policy set, so that little policy editing is required for deployment.</p>		
2.	<ul style="list-style-type: none"> • Buffer Overflow Protection <p>2.1 It should provide protection against classic buffer overflow memory attacks.</p> <p>2.2 The Protection should be based on behavior, not signatures, so that even unknown buffer overflows are blocked.</p>		
3.	<ul style="list-style-type: none"> • Application Firewall <p>3.1 It should be able to monitor and block network traffic for threats.</p>		
4.	<ul style="list-style-type: none"> • Out-of-the-Box Policies <p>4.1 It should contain a group of ready-to-run protection policies for standard applications and OS functions.</p> <p>4.2 The default policies should provide coverage for all applications when</p>		

	<p>installed on a system - with minimal time needed to edit the policy.</p>		
5.	<ul style="list-style-type: none"> • File and Registry Protection/ Lockdown <p>5.1 It should protect system files and registry entries from modification or deletion.</p> <p>5.2 It should be able to provide process control based on the application initiating the change, the target file/ registry key, the user/group attempting the change and finally based on additional arguments used when starting the application.</p> <p>5.3 It must provide the ability to lock files/ key down from all applications, while allowing other applications to edit or read the file/key - so that enterprise admin tools can perform their task without manual intervention.</p>		
6.	<ul style="list-style-type: none"> • User Privilege Level Controls <p>6.1 As a part of 'Policy enforcement', user rights can be de-escalated by policy. Thus a user with "admin" rights may be downgraded to "user", with fewer rights.</p> <p>6.2 It should provide a way for users to 'override' the protection in case they need to change the system in ways that would normally be blocked.</p>		
7.	<ul style="list-style-type: none"> • Device Controls <p>7.1 It should be able to prevent use of devices e.g. USB devices/ CD-ROM drives.</p>		
8.	<ul style="list-style-type: none"> • Broad Platform Support <p>8.1 It should be able to provide Prevention and Monitoring support for heterogeneous environment, including Windows, UNIX and Linux .</p>		
9.	<ul style="list-style-type: none"> • Policy Enforcement 		

	<p>9.1 The policies should control the behavior of system services and user actions, It should ensure that people or applications, cannot initiate harmful functions even if they are requested to do so. An example of a disallowed user function would be an attempt to run a *.bat or *.exe file attachment from an incoming e-mail. Similarly, System Services would not be allowed access to IIS information.</p> <p>9.2 The protection should be both extendable/ customizable and prevent users from avoiding the protection (or shutting it off).</p>		
<p>10.</p>	<ul style="list-style-type: none"> • Pre-defined Graphic and Text Reports – textual and graphical <p>10.1 It should come with the most common reporting metrics pre-configured in textual or graphic reports.</p> <p>10.2 It should provide custom query/report generation tools for generating new queries.</p>		
<p>11.</p>	<ul style="list-style-type: none"> • Security Event Forwarding <p>11.1 It should be able to Filter and forward security events to the central console.</p> <p>11.2 It should provide additional alerting methods to send events on to other systems - via e-mail, SNMP or output logs.</p> <p>11.3 The Alerting should be configurable to provide forwarding of only specific events, as well as event consolidation to reduce size and volume of forwarded data.</p>		
<p>12.</p>	<ul style="list-style-type: none"> • Centralized log collection for easy search, archival and retrieval <p>12.1 It should collect defined log files in a central log report for storage and retrieval.</p> <p>12.2 It should provide high volume 'bulk' event</p>		

	<p>logging to consolidate events to reduce event bulk and avoid cluttering the console with unneeded information.</p>		
13.	<ul style="list-style-type: none"> File and Registry Monitoring <p>13.1 It should monitor critical system files and registry entries to track unauthorized edits or deletions.</p>		
14.	<ul style="list-style-type: none"> Smart Event Response <p>14.1 It should provide pre-defined, automated responses to events. Actions include alerting the administrator, disabling the user account, logging the event..</p>		
15.	<ul style="list-style-type: none"> Sophisticated policy-based auditing and monitoring <p>15.1 It should have policy based auditing of systems that produce logs of library listed activities that are available for administrative and system/regulatory compliance use.</p> <p>15.2 It should be able to provide monitoring of security, compliance and configuration events that is extensible and configurable.</p>		

Adequate number of anyother devices such as AAA,server Load balancer etc which are required to make the solution work would have to be included by the bidder.

1.2.3.7 Server Load Balancer (Qty: 1+1)

S.#	Description / Specification	Compliance	Deviation
1.	Architecture		
	○ 19" rack mountable		
	○ Server load balancer should have ASIC based architecture & not PC based architecture		
	○ Should have min 4 x 10/1000/1000 Base T Ports.		
	○ Should support minimum 1 Million concurrent Sessions		
	○ Should support minimum 1,00,000 connection per second		
	○ Should support minimum 1 Gbps L7 throughput and upgradeable to 2 Gbps without change in hardware or any new addition in hardware		
	○ Should support logical interfaces		
	○ Should support Port Aggregation IEEE 802.3ad		
	○ Should support VLAN Trunk IEEE 802.1Q		
	○ Should have 512 MB RAM from day 1 and upgradeable to 1GB RAM.		
	○ Should support following deployments		
	○ Routing Mode : where client-side and server-side VLANs are on different subnets		
	○ Bridge Mode: where client-side and server-side VLANs are on the same subnets.		
2.	Load Balancing Features		
	○ Should support minimum 1000 or more real Servers for load balancing.		
	○ Should support minimum 500 or more Virtual servers.		
	○ Should support minimum 500 or more server farms		
	○ Should support following load balancing algorithms		
	○ Cyclic - Round Robin		
	○ Hash		
	○ Weighted Cyclic		
	○ Least Connections		
	○ Least number of users.		
	○ Least Bandwidth		
	○ Least Response time		
	○ Server load balancing based on SNMP parameter like CPU load, Memory utilization etc		
	○ Should support Client NAT & Server NAT		
	○ In case of Server / Application failure device should detect it in not more than 30 seconds.		
	Should support following content based Load balancing features		
	○ It should be able to support global load balancing in future with the help of soft or internal/external hardware upgrade.		
○ HTTP Header based redirection			

	<ul style="list-style-type: none"> ○ URL-Based Redirection ○ Browser Type Based Redirection ○ Preferential Treatment (Cookie-Based) 		
3.	Server Management Features <ul style="list-style-type: none"> ○ Should support Graceful shutdown of Servers ○ Should support Graceful Activation of Servers ○ Should able to redirect traffic based on Source IP, Destination IP & TCP PORT 		
4.	Segmentation/ Virtualization		
5.	Health Monitoring <ul style="list-style-type: none"> ○ Should provide individual health checks for real servers & farms ○ Should allow to monitor protocol like HTTP, SMTP, POP, FTP etc ○ Should allow to configure Customize health probes based on TCP & UDP parameters ○ Should provide GUI to configure Health Monitoring ○ Optional Support for user defined / custom health checks as per the requirement. 		
6.	Redundancy <ul style="list-style-type: none"> Should support industry standard redundancy protocol like VRRP. Should support transparent failover between 2 devices Should Supports active-standby and active-active redundancy. 		
7.	Management <ul style="list-style-type: none"> Should support following Management Applications ○ Telnet ○ SSH ○ http ○ HTTPS ○ Console ○ SNMP (V1, V2 and V3). ○ Should support GUI for configuration & monitoring ○ based redirection 		
8.	Product shall be provided with all the required licenses, management server software as applicable to meet all the above mentioned specification & proposed solution.		

1.2.3.8 Authentication, Authorization and Accounting (Qty: 1)

S.#	Description / Specification	Compliance	Deviation
1	Should be a hardware based appliance solution / Server Based solution for Authentication, Authorization and Accounting and 802.1x implementation.		
2	Shall perform AAA function for all configured networking devices that includes routers, switches, firewalls, IDS etc in the network.		
3	Should support RADIUS in conformance to the following IETF RFCs		
	RFC 2138, Remote Authentication Dial In User Service		
	RFC 2139, RADIUS Accounting		
	RFC 2865, RFC 2866, RFC 2867, RFC 2868, RFC 2869		
4	Should provide login authentication functionality.		
5	Upon successful login, the system shall be configurable in way so that command access to certain devices for a particular username can be restricted.		
6	The system should log failed attempts of authentication and command execution.		
7	Should allow the network administrators to control who can log in to the network from wired connections, What privileges each user has in the network, What accounting information is recorded in terms of security audits or account billing, What access and command controls are enabled for each configuration administrator		
8	Should support downloadable ACLs for any Layer 3 devices like routers, firewalls.		
9	Should support user and administrative access reporting, dynamic quota generation and time based restrictions based time of day and day of week		
10	Should support PAP, CHAP and MS-CHAP, EAP-MD5, EAP-TLS password protocols.		
11	Should support PEAP to provide a new, secure, and client-server authentication method for wireless networks.		
12	Should support packet-filtering mechanism to block traffic on all but from necessary AAA-specific TCP and User Datagram Protocol (UDP) ports.		
13	Should support SSL for administrative access		
14	Should support integration with Windows user database and LDAP database.		

15	Should allow the main network administrator to control whether other network administrators can change passwords during Telnet sessions.		
16	Should support PKI		
17	Should support Network Time Protocol for time synchronization with the network.		
18	Should be integrable with the offered Security management system.		
19	Should support Windows user database integration for authentication function		
20	Should support access connection type of wired/wireless LAN, dialup, broadband, and virtual private networks (VPNs)		
21	Should be integral with the offered Antivirus mediation server to determine antivirus posture at network access		
22	Should support HTTP port allocation feature to configure the range of TCP ports used by the AAA system for administrative HTTP sessions.		
23	Should support 802.1x authentication for end stations of the campus network.		
24	Should support the following features –		
	Lightweight Directory Access Protocol (LDAP) and Open Database Connectivity (ODBC) user authentication support		
	Device command set authorization		
	Network access restrictions		
	User and administrative access reporting		
	Restrictions such as time of day and day of week		
	User and device group profiles		

1.2.4 SDC EMS Architecture

Enterprise Management System (EMS)

The proposed EMS solution should manage service availability of various citizen-centric services hosted at Punjab SDC by identifying critical services, the infrastructure they depend on and the relevant applications. The proposed solution should provide comprehensive and end-to-end management of all the components for each service including Systems ,Database and Application infrastructure.

1. Infrastructure Management System

(a).Network Fault Management:

- To provide comprehensive Event Management, Event Correlation, Root-cause Analysis for any Network fault, Service Management including SLA monitoring etc. for the SDC

(b.)Performance Management

Performance Management System must monitor performance management across key parts of the PUNJAB SDC infrastructure. Extended performance management console will be provided to bidder .Bidder must integrate network & server performance information & alarms in a single console & repository and thus provide a unified reporting interface for network ,server & database components at SDC.

- The extended Network Performance Management consoles must provide a consistent report generation interface at PUNJAB SDC for monitoring devices at SDC. Using central console bidder should monitor & provide all required network performance reports (including latency, threshold violations, packet errors, availability, bandwidth utilization etc.) for the network infrastructure managed at SDC.
- Bidder should define necessary performance threshold for monitored devices at SDC using extended NMS console and forward threshold exceptions to central fault management console for centralized view of alarms generated.
- Bidder should monitor near real time performance of critical devices like bandwidth\cpu utilization using extended performance management console.
- Bidder should configure & generate necessary Performance reports like **At-A-Glance** , **Trend Reports** , **Top N Reports** , **What-If Reports** , **Service Level Reports** , **Health**

Reports for monitored network devices ,servers & database using extended monitoring consoles.

(i) Datacenter Network Traffic Analysis System

Analyzing network traffic pattern is very critical component to help in troubleshooting issues related to network traffic congestion .Proposed tool should help in identifying type of traffic flowing from SDC to SWAN & SWAN to SDC based on various applications & protocols for capacity analysis and providing breakup of traffic utilization on critical interfaces.Tool should help in identifying what application servers are generating maximum traffic in SDC thus consuming most amount of bandwidth.Tools should provide following features

1. Tool should help in determining whether right traffic is flowing through or it is rogue traffic which is not required.
2. The tool must support heterogeneous Flow monitoring and traffic analysis for any of technology vendors like NetFlow, J-Flow, sFlow, Net-stream, IPFIX technologies.
3. The solution should be of the type passive monitoring without a need to install any probe or collector for data collection.
4. The proposed solution must be able to monitor and report on unique protocols per day and display utilization data and baselines for each protocol individually by interface.
5. The proposed traffic analysis system must be capable of automatically detecting anomalous behavior such as virus attacks or unauthorized application behavior. The system should analyze all NetFlow traffic and alert via SNMP trap and syslog of any suspicious activity on the network and send it to central network console.
6. Proposed tool must integrate with Central Network Fault & Performance Management System seamlessly for sending alarms and context sensitive reporting.
7. The proposed traffic analysis system should provide visibility into new and unknown traffic patterns which is critical for ensuring the performance of networked applications, as well as identifying security risks. It should provide real-time analysis of traffic behavior in infrastructure to help ensure network delivers application services reliably and securely.It should provide Enterprise Network Behavior Summary for:
 8. Fragmented Packet Sources, High Volume Sources, Packet Fan Out Sources,Syn/Rst only sources,High Flow Sources,Number of TTL Expires
9. The solution must provide the following NetFlow based metrics:
 10. Rate,Utilization,Byte Count,Flow Count,IP hosts with automatic DNS resolution,IP conversation pairs with automatic DNS resolution,Router/interface with automatic SNMP name resolution,Protocol breakdown by host, link, ToS or conversation,Utilization by bit pattern matching of the TCP ToS field,AS number,BGP next hop address,IPv6 addresses

11. The proposed system must be capable of sending alerts via SNMP trap. Alerts should have the following configurable parameters:
12. The ability to choose any protocol, interface or group of interfaces, ToS, rate, volume, utilization, time filters (i.e. business hours) over a specified threshold being monitored by the system.
13. Database Definition
 - 13.1. The proposed solution must keep historical rate and protocol data for a minimum of 12 months (most recent) in its current long term operating database. All data in that database must have a maximum 15 minute window granularity without roll up. A user must be able to select any 15 minute window over the last 12 months and display unique utilization and protocol data for every monitored interface.
 - 13.2. The proposed solution must keep historical rate and protocol data for a minimum of 30 days (most recent) in its short term operating database. All data in that database must have a maximum 1 minute window granularity. A user must be able to select any 1 minute window over the last 30 days and display unique utilization and protocol data for every monitored interface.
 - 13.3. The proposed solution must be able to monitor and report on unique protocols per day and display utilization data and baselines for each protocol individually by interface.
 - 13.4. The proposed solution must keep and report on unique hosts and conversations per day for each monitored interface.
 - 13.5. The system must maintain this custom ToS based information for each interface for at least 12 months at a minimum 15 minute granularity.
 - 13.6. All custom reports from the long term database must support the ability to be run manually or scheduled to run automatically at user selectable intervals.
 - 13.7. All reports should be generated and displayed directly by the system from a common interface.
 - 13.8. The system should allow via API for Excel to download data to generate reports.
 - 13.9. The system must be able to restrict views and access for defined users to specific routers, interfaces, and reports.
14. The user must be able to generate reports from the long term database based on specific thresholds defined by the user where the threshold can be compared to rate, utilization or volume of every monitored interface as a filter for inclusion in the report.
15. Search for any traffic using a specific configurable destination port, or port range, autonomous system (AS) number, BGP next hop IP address, ToS bit, clients or servers that are experiencing more than a specified number of TCP resets per hour, IPv4 or IPv6 conversation bad IP Header, unreachable destination, TTL expired, traceroute requests, MAC addresses, TCP flags, VLAN.

16. NetFlow collection device must support a minimum of 5 million flows per minute up to 9 million flows per minute and be capable of storing gathered information in a common database where all long term reporting information is held.
17. The overview page must include an email function that provides a GUI driven method for emailing the page in PDF format as well as for scheduling the email of this page at regular intervals without user intervention to one or more recipients.
18. The system must provide the ability to group interfaces into functional groups based on any user criteria. The grouping function must allow users to create group names and add interfaces into that grouping for reporting purposes. Once created, these groups must be available for selection within custom reports as a mechanism to include multiple interfaces without individual selection for inclusion.
19. The system must support interface specific report generation for every monitored interface in the network. It must provide menu or GUI driven access from the main system page that allows users to select from the automatically generated interface list and navigate to interface specific information.
20. This page should display a graph representing the total number of NetFlow flows that the data was derived from. It must represent flows for the selected period of time, for this interface.
21. The user must be able to easily change the data type of the main interface view from protocol specific to a single graphical representation of utilization over multiple points in a 24 hour day as compared to all other similar points in the days in that month.
22. The monthly view must provide a graphical representation of the level of utilization for each fifteen minute interval of each day of the month.
23. The user must be able to easily change the data type of the main interface view to a tabular format showing the increase or decrease of traffic generated by that protocol as a percentage using discrete least-squares approximation to find a best fit line of growth.
24. The proposed traffic analysis system should provide visibility into new and unknown traffic patterns which is critical for ensuring the performance of networked applications, as well as identifying security risks. It should provide real-time analysis of traffic behavior for every client and server in infrastructure to help ensure network delivers application services reliably and securely. Network behavior analysis should help in :
 - .1. Providing early insight into virus-infected hosts and worm attacks
 - .2. Identifying unauthorized or incorrectly configured server activity
 - .3. Alerting on unauthorized application deployments
 - .4. Identifying network misconfigurations, such as routing loops and inaccessible network sources
 - .5. Reporting the sources of fragmented traffic

It should provide Enterprise Network Behavior Summary for:

- Fragmented Packet Sources
- High Volume Sources
- Packet Fan Out Sources
- Syn/Rst only sources
- High Flow Sources
- Number of TTL Expires

(iii) Server & Database Performance Management System

- All collected performance information for monitored servers must be stored in existing NMS Performance Monitoring database. Bidder has to import/integrate server & database performance monitoring data & alarms into existing NMS providing centralized performance reporting & alarm information for monitored Network & Servers in one console.
- Monitored servers should be discovered in extended NMS console to provide topology view of monitored network devices as well as servers depicting in topology what all servers are connected to what all ports of monitored switches in SDC.
- The proposed tool should be able to monitor various operating system parameters such as processors, memory, files, processes, file systems, etc. where applicable, using light footprint agents on the servers to be monitored.
- The proposed tool should support operating system monitoring for various platforms including Windows, UNIX and Linux.
- The proposed server monitoring solution should detect threshold violations in real-time, sending an alert to the extended network fault management console .
- Proposed Performance Monitoring Solution must Provide At-A-Glance report for servers monitored. The following charts must appear in reports for servers: Availability ,CPU Utilization ,Disk Faults, Disk I/O ,File Cache Miss Rate ,Interface Utilization ,Latency ,Pages Paged ,Pages Swapped ,Physical Memory ,System Partition Utilization ,Total Packets ,User Partition Utilization ,Virtual Memory Utilization
- The Monitoring tool should support database performance agents for performance reporting of standard RDBMs like Oracle, MS-SQL, Sybase and DB2.
- Database performance management solution for Distributed RDBMS must include hundreds of predefined scans for monitoring various database, operating system and network resources.
- Bidder should integrate Database performance monitoring solution with extended fault & performance monitoring console in order to view database specific alarms & run performance reporting from extended NMS consoles.

(c).Application Performance Management

Application Performance is very critical measure for PUNJAB SDC for monitoring critical citizen centric applications accessed by external users. The proposed Application Performance Management System at PUNJAB SDC must provide the following features:

- The proposed solution must determine if the root cause of performance issues is inside the monitored application, in connected back-end systems or at the network layer from a single console view.
- Bidder should integrate proposed APM tool with existing extended NMS Fault Management console to forward application specific alarms & map them to application service definitions in NMS console. In event NMS received application performance alarm from APM tool it should show impacted services and raise a service degradation alarm depicting root cause of service degradation is bad application performance. This will help SDC operators to identify that application service is degraded due to bad application performance & not at network layer. This will help state in solving blame game problems between various stakeholder to determine whether issue lies at network(SWAN) or at SDC infrastructure.
- The proposed solution should be able to proactively monitor all real user transactions; detect failed transactions and help diagnosis of problems that affect user experience and prevent completion of critical business processes.
- The proposed solution must provide deeper end-to-end transaction visibility by monitoring at a transactional level and without deploying any software at end user desktop. The solution must provide a single view that shows entire end-to-end real user transaction and breaks down times spent within the application components, SQL statements, backend systems and external 3rd party systems.
- Real time end user response monitoring & application performance diagnostic should be tightly integrated out of the box without a need to perform extensive customizations.
- The proposed solution must be able to provide analysis of all problems and find root-cause for problems showing the problematic areas within the application infrastructure..
- The proposed solution must be able to detect production Memory Leaks from mishandled Java Collections and isolate exact component creating leaking Collection.
- The proposed solution must allow monitoring granularity of no more than 15 seconds for all transactions.
- The proposed solution must provide real-time monitoring of resource utilization like JVM memory usage, Servlets, EJB pools, DB connection pools and Threads.

- The proposed solution must tie SQL statements to components involved, i.e. SQL queries should be able to get correlated to the Java components calling them. This should be clearly visible by showing the transaction call stack ("Blame stack").
- The proposed solution must identify any changes to application configuration files(.xml, properties etc), File system or application code and be able to correlate changes to application performance dynamically in production environments.
- The proposed solution must proactively identify any thread usage problems within applications and identify stalled (stuck) threads. The proposed solution must also monitor web services across multiple processes (cross JVM tracing)
- The proposed solution should allow access to performance data both using a Graphical user interface (GUI) and over the web (web based access) and provide ability to monitor performance of applications up to the method level of execution (Java/.Net method) 24x7 in production environments with negligible impact on monitored application.
- The proposed solution must provide for dynamic instrumentation of application code, i.e. enhance be able out of the box monitoring with extra monitoring definitions without having to restart application.
- The proposed solution should measure the end users' experiences based on transactions without necessitating installation of client agents / probes on end-user desktops. · The proposed solution should measure the end users' experiences based on real user transactions & not synthetic or robotic transactions generated without. The solution should be an appliance-based system acting as a passive listener on the network thus inducing zero overhead on the network and application layer.
- The proposed system must be able to detect user impacting defects and anomalies and reports them in real-time. The proposed system must also be able to provide user usage analysis and show how user's success rate, average time and transaction count has changed over a specific period of time such as current week versus previous week.
- The proposed system must be able to pro-actively determine exactly which real users were impacted by transaction defects, their location and status.
- The proposed system must be able to provide the ability to detect and alert when users experience HTTP error codes such as 404 errors or errors coming from the web application.
- The proposed system must allow to dynamically instrument components of transactions revealed in a trace session without restarting the Java Virtual Machine (JVM).
-
- The solution must show out of the box application triage maps that allow to instantly grasp the layout of the applications in the environment in a visual manner to help identify and triage current and emerging problems.

- The solution should have provision for automatic transaction discovery, for example by setting up some bounding parameters to describe transactions like the web site, the language, and parameters (such as post, query, and cookies).
- The proposed solution must provide a single view that shows entire end-to-end real user transaction and breaks down times spent within the J2EE application components, SQL statements, backend systems, industry standard databases and external 3rd party systems.
- The proposed solution must gather available performance indicator metrics from all within real-time production environments and real user transactions 24x7 with minimal overhead on monitored applications
- The proposed solution must provide means to integrate monitoring data with SNMP/TCPIP managers.
- The proposed solution must be able to monitor application performance to all connected backend systems and supporting external systems within the application.
- All application stakeholders (i.e. DBA, Operation and application developers) must get performance data pertaining to their specific areas from Java/.Net application agent within the application server
- The proposed application performance management solution must support monitoring of various industry standard application servers like JBOSS Application Server ver 4.23 and above.

(d.) Helpdesk Management System

Proposed Helpdesk Management software at SDC should integrate with existing helpdesk running at SWAN in order to provide State complete status of issues, incidents, service level violations and their resolution time for both SWAN & SDC infrastructure in a single helpdesk console. Bidder should create separate view for SDC operator to log & view SDC incidents.

- The proposed helpdesk solution must provide flexibility of logging, viewing, updating and closing incident manually via web interface.
- The proposed helpdesk solution must support ITIL processes like request management, problem management, configuration management and change order management with out-of-the-box templates for various ITIL service support processes.
- Each escalation policy must allow easy definition on multiple escalation levels and notification to different personnel via window GUI/console .
- The proposed helpdesk solution must have an updateable knowledge base for technical analysis and further help end-users to search solutions for previously solved issues.
- The proposed helpdesk solution must support tracking of SLA (service level agreements) for call requests within the help desk through service types.

- The proposed helpdesk solution must integrate tightly with the Knowledge tools and CMDB and should be accessible from the same login window.
- The proposed helpdesk solution must allow the IT team to see the CI relationships in pictorial format, with a specified number of relationships on single window.
- The proposed helpdesk solution must have a built-in workflow engine. The proposed helpdesk solution must support Non-linear workflows with decision based branching and the ability to perform parallel processing. It should also have a graphical workflow designer with drag & drop feature for workflow creation and updates.
- The proposed helpdesk solution must have an integrated CMDB for better configuration management & change management process. CMDB should have more than 50 CI families, 140 CI Classes and 70 CI Relationship Types out of the box. Both Service Desk & CMDB should have same login window.
- It should support remote management for end-user & allow analysts to do the desktop sharing for any system located anywhere, just connected to internet.
- Remote desktop sharing in Service desk tool should be agent less & all activity should be automatically logged into the service desk ticket.
- Proposed helpdesk must be certified on all 14 ITIL v3 processes by certifying agencies like pink elephant.

(e).Host based Access Control for securing critical datacenter servers

- Host based security solution must allow controlling of access to system resources including data files, devices, processes/daemons and audit files.
- The solution should Self-protect itself – Must be able to prevent hackers with root access from circumventing or shutting down the security engine. Must use a self-protected database for storing all security information.
- The solution should provide Rights Delegation - Must provide the ability to designate specific users as Administrators, Auditors, and Password Managers etc with appropriate rights. Must also provide the ability to designate specific users as Subordinate or Group Administrators, to manage users and file permissions for their Group
- The solution should support cross platform Management – Must support management and policy distribution across Windows, Linux and Unix platforms from a central management console. It must support the deployment of the same policies across multiple servers ensuring consistency of security policies across machines in the enterprise.
- The solution must provide capability to allow access to sensitive resources only through approved programs.

- Administrators must be able to define critical files that are not supposed to change. If these files are modified, the process that checks the sensitive files must find that the files have changed and write an audit record.
- The solution should allow protection of files on even non-NTFS file systems like FAT and CDFS.
- The solution must provide support for IPv6 and FIPS140-2 and must provide Services and Registry Values Protection on Windows
- The solution must provide administrative password checkout function. It should provide workflow for requesting and checking out a system-generated. The solution should provide the functionality to force the user to check the password in once their task is completed, or PUPM should provide the capability to be configured to automatically check the password in after a specific time period; and it can be a manually forced check in as well.
- The privilege user password management (PUPM) must provide a fully functional and customizable workflow that provides common out-of-the-box use cases for PUPM. The solution must provide a break glass feature. A break glass scenario occurs when a privileged user needs immediate access to an account that they are not authorized to manage. Break glass accounts are privileged accounts that are not assigned to the user according to their role. However, the user can obtain the account password immediately, without approval, if the need arises. This eliminates the possibility of a delay for an admin to approve the request. All transactions related to the break glass scenario must securely be logged for audit purposes.
- The solution should provide a feature to eliminate passwords from scripts. Via PUPM, it should be possible to replace hard-coded passwords in scripts with privileged account passwords that are generated by PUPM only when needed.
- The solution should provide a unified web based console which consolidates all aspects of privileged user management under a single console — host access control and privileged user management across physical and virtual systems, devices and applications.
- The PUPM must support a wide range of virtualization platforms including but not limited to: VMware ESX, Solaris 10 Zones, LDOMs, Microsoft Hyper-v, IBM VIO, AIX LPAR, HP-UX VPAR, Linux Xen and Mainframe x/VM, providing for more consistent security management of access control risks across these virtual partitions, in addition to physical platforms.

EMS Integration Points

- Network fault management system should attach an asset identifier when submitting a helpdesk ticket. In case the asset is not found in the helpdesk database, it should be automatically created prior to submitting the ticket.

- When certain user tries to make any change on network device through fault management console a helpdesk ticket should be generated automatically. The Service Desk operator must have the ability to view the proposed configuration change. Once the ticket is approved the admin is automatically notified and is able to proceed with the change.
- The existing Fault Management Solution must support integration with helpdesk or trouble ticketing system such that integration should Associates alarms with Service Desk tickets in the following ways:
 - o Manually creates tickets when requested by Fault Management GUI operators
 - o Automatically creates tickets based on alarm type
 - o Provides a link to directly launch a Service Desk view of a particular ticket created by alarm from within the Network Operation console.
 - o Maintains the consistency of the following information that is shared between alarm and its associated Service Desk ticket including status of alarms and associated tickets and current assignee assigned to tickets.
- Helpdesk ticket number created for associated alarm should be visible inside Network Operation Console. Helpdesk incident can be launched once clicked on ticket number for associated alarm from within Network Operation Console.
- SLA's violation on monitored application end user response time must open a helpdesk incident out of the box.
- Bidder should integrate NMS consoles to provide unified workflow between the fault and performance management systems including bi-directional and context-sensitive navigation, such as
 - Navigate from the Topology View to At-a-Glance or Trend Reports for any asset
 - Navigate from the Alarm View to At-a-Glance, Trend or Alarm Detail Reports
- Bidder should integrate existing NMS at PAWAN with additional Application, Server & Database, helpdesk monitoring tools proposed at SDC in order to provide single unified view of monitored SDC infrastructure. Bidder should define application service at NMS & map Application, Server & Database Performance alarms from SDC monitoring tools to application service definition at existing NMS console at PAWAN. This will help state level operator to pin point if hosted SDC Application service outage is due to bad application performance or due to bad hosting server\database performance\availability or due to bad SWAN or SDC network performance\faults. This will help state to pin point root cause of application service outage by identifying which component is impacting and hence come out of blame game whether problem is at SDC level or at SWAN level.

1. Host-based OS Access Control System

The proposed Host-based Server Access Control Solution should be able to protect critical server infrastructure in the SDC environment and minimize security risks by regulating access to confidential data and mission critical services. The solution should provide policy-based control of who can access specific systems, what they can do within them, and when they are allowed access for all servers within the SDC. Specifically, it should proactively secure access to data and applications located on Windows ,Linux, UNIX and system servers throughout the proposed SDC infrastructure.

- Host based security solution must allow controlling of access to system resources including data files, devices, processes/daemons and audit files.
- The solution should intercept security-sensitive events in real-time, and evaluate its validity before passing control to the OS.
- The solution should be Non-Intrusive – Must make no changes to the operating system kernel or binaries. Software must allow for quick uninstall if necessary.
- - The solution should Self-protect itself – Must be able to prevent hackers with root access from circumventing or shutting down the security engine. Must use a self-protected database for storing all security information.
- The solution should provide Rights Delegation - Must provide the ability to designate specific users as Administrators, Auditors, and Password Managers etc with appropriate rights. Must also provide the ability to designate specific users as Subordinate or Group Administrators, to manage users and file permissions for their Group
- The solution should support cross platform Management – Must support management and policy distribution across Windows, Linux and UNIX platforms from a central management console. It must support the deployment of the same policies across multiple servers ensuring consistency of security policies across machines in the enterprise.
- The solution must provide capability to allow access to sensitive resources only through approved programs.
- The solution should provide Process Controls - Administrator must be able to control the circumstances, under which authorized users may terminate sensitive processes (daemons), including time and day, where from, etc.
- The solution should prevent tampering of audit files by anyone while it is running on the machine. Additionally, any change of rules should always be audited.
- The solution must provide a warning mode that can be used during implementation to verify policies and their impact before deployment.
- The solution should allow protection of files on even non-NTFS file systems like FAT and CDFS.

- The solution should be able to fully work with Win 2K Active Directory in both directions, ensuring any existing deployment of AD infrastructure is not affected.
- The solution must provide support for IPv6 and FIPS140-2
- The solution must provide Services and Registry Values Protection on Windows.

1.2.4.1 Technical Specifications - EMS

1.2.4.1.1 Hardware Specification (Quantity – Minimum 3 Servers)

S.N	DESCRIPTION	QTY	Page Reference in product data sheet
	EMS	Min 3 servers	
S.No.	Specifications	Compliance	Page Reference in product data sheet (If any)
	Hardware features	(Yes/No)	
I	1* Quad core processor scalable up to 2*Quad Core Processor (2.0 GHz or above)		
II	2MB or above L2 cache per core CPU		
III	Processor should be latest series/generation for the server model being quoted		
IV	Should have support for 32/ 64 bit Linux/Windows OS platform		
V	4GB memory scalable up 16 GB		
VI	Min 2x 146 GB 10K RPM SAS HDD		
VII	2 Ethernet Ports of 100/1000 Mbps		
VIII	Should network management port for remote administration		
IX	All cards should be on 64 bit PCI-X/PCI-e slots/module operating at minimum 133MHz. Minimum 2 PCI slots should be free		
X	Redundant, hot swappable, power/cooling units		
XI	RAID Controller: RAID controller to support various levels of RAID		

Note: Minimum 3 no of servers need to be quoted. However bidder has to provide the sufficient number of quantity over and above to meeting the solution requirement and hence Bidder can suggest better hardware, software, quantity to meet the requirement.

1.2.5 Functional requirement for Disaster Recovery Management Software

Disaster Recovery Management Software enables operational automation of the entire life cycle of the IT DR process, while masking the heterogeneous technology complexity.

The scope of the Disaster Recovery Management Software will be for the entire DR infrastructure that will be covered under this RFP.

The following features must be supported by Disaster Recovery Management software that will be used for Monitoring, DR Drills, Failover, SLA Reporting and Replication management for various applications that would be hosted in SDC.

“DR location for Punjab SDC will be (NIC Data Centre location to be confirmed at the later stage) who would be facilitating the DR activities in their Data Centre. The DR will be a Storage based replication from DC to DR., The replicator which will be positioned in the DR and will have the capacity to virtualize the backend storage on which NIC is giving 25TB initially. In future State may go beyond 25 TB space.

S No	Description	Compliance
1	Recovery Monitoring	
	Real time monitoring of Recovery Point Objective at database and application level.	
	DR solution health – real time monitoring of primary & DR subsystem health and alerts on DR solution	
	Provide alerts on event threshold conditions such as RPO deviation and replication log space full at application level and support policy based actions for these alerts	
	DR Manager dashboard – single dashboard to track DR readiness status of all applications under DR	
2	Recovery Automation	
	Central console to start, stop & track recovery workflows for each application.	
	Report on number of steps and estimate of time for failover recovery for each application.	
	Automated failover of each application to the DR site with single click.	
	A ready to use library of recovery automation actions for third party databases and replication products. This must significantly reduce custom development of scripts and speed deployment of DR solutions.	
3	DR Drill	
	Central console to start, stop & track DR drill related workflows for each application.	

	Readymade, single click based automated switch-over and switch-back workflows for industry popular databases and replication products	
	Pre-flight check DR workflows to ensure conditions are met to ensure a successful drill	
	Automated drill reports with evidence of control and granular timing of each step.	
4	Reporting	
	Readymade reports on RPO deviation, RTO deviation, Datalag, Application DR readiness status, WAN utilization	
	Ability to create UI based custom reports. Data can be exported to popular reporting engines.	
5	Management	
	<p>Built-in file replication that is not tied to a specific platform or OS for application environment protection with the following features:</p> <ul style="list-style-type: none"> • Replication from multiple sources to multiple destination files/folders and nested files & folders • Preserves file attributes & option to skip or copy open files • Maintain primary & DR equivalence. Files deleted on the primary will be deleted on DR • Provides log of replicated file names, pending files and number of files to be replicated and statistics on throughput • Support replication for Unix symbolic links • Restart replication after a break from last successful replicated point • Replicate only portions of the file that have changed • On the fly compression for reduced bandwidth • Ability to provide alerts when specific files change on production systems 	
	Notification using SMS and email and support for notification lists to handle groups of users at a time	
	The software must be able to integrate any application into its DR management framework in the field, for application environment and configuration monitoring	
	The software must provide GUI based application component dependency map across primary and DR sites so that failure identification is quick and easy	
	The software must provide monitoring and management capability for remote management.	
	The software must have the capabilities to be integrated with the major EMS systems.	
	The software must provide infrastructure/application based and role based access control to users to support large environments securely.	
	The software should provide single integrated management interface to meet all the disaster recovery management functionality	

5	Support	
	The software must support major platforms including Linux, Windows, Solaris, HPUX, and AIX.	
	The software must have inbuilt support for several popular databases including Oracle, MSSQL and DB2.	
	The software must have inbuilt support for several replication products including Oracle Dataguard, MSSQL Native Replciation, HDS TrueCopy and HUR, EMC SRDF, HP Continuous Access among other. .	
	The software must support physical and virtual servers across primary and DR sites without any restrictions.	
6	Management Console Server	
	The solution must provide with DR Management Console Servers with the required licenses and future scalability	

Roles & Responsibility for DR

The primary role of DCO within the Disaster Recovery is to create & maintain a Disaster Recovery Plan to support a timely and effective resumption and recovery of all interrupted state services running from state data center.

The scope of disaster recovery plan shall include but not limited to:

1. Gathering need of services running from SDC.
2. Understanding policies, impact, and risk of services running from SDC.
3. Define Key Assets, Threats and Scenarios.
4. Define Recovery window.
5. Define Recovery solutions for data and services
6. Communication plan including escalation, notification, and declaration plans for each service running from state data centre.
7. Roles and responsibilities of teams working during disaster.
8. Exercising the plans, either to test and improve the plans, or to actually recover from a disaster situation that affects Service Delivery.
9. Updating, maintaining, managing, testing, and implementing any portion of the Disaster Recovery plans and activities that relate to the continued provisioning of the Services
10. DCO will be the primary point of contact that will communicate to PSEGS, affected services delivery manages about the disaster and recovery windows and procedure's.

11. It is the complete responsibility of the DCO to meet all defined SLAs with PSEGS or any other State Department / State PSUs in event of Disaster.

12. “DR location for Punjab SDC will be (NIC Data Centre location to be confirmed at the later stage) who would be facilitating the DR activities in their Data Centre. The DR will be a Storage based replication from DC to DR., The replicator which will be positioned in the DR and will have the capacity to virtualize the backend storage on which NIC is giving 25TB initially. In future State may go beyond 25 TB space.

1.2.6 Functional requirement Specification for Cloud

The cost will be discovered separately. The solution asked in cloud should cover the entire DC IT Infrastructure and the licence discovery of all the modules should be there (chassis/server/processor/socket/instance) whichever is applicable with proper weightage for price discovery for future procurement whenever it is required.

Cloud Roles & Responsibility

DCO shall manage, maintain and implement cloud for the state and departments. Its roles and responsibilities include but not limited to:

1. Adapting, porting or deploying an application to a cloud.
2. Designing the private cloud, understanding and evaluating the technologies and vendors needed to deploy the private cloud.
3. Day-to-day cloud maintenance and monitoring activities.
4. Capacity planning and application sizing for deploying an application to cloud.
5. Maintenance of SLA's.
6. Change management and document management.

1.2.6.1 General Requirement

S. No.	Requirements
i.	The Solution should be capable of allowing applications to self-service compute, network and storage infrastructures automatically based on workload demand
ii.	The Solution should be capable of decoupling applications and application infrastructure configurations in portable containers called images
iii.	The tool should provide image library, where Software and server images can be maintained. Facilities should be there to import new server templates to the library and registering , so as to use the same for provisioning the new virtual servers
iv.	The Solution should be able to isolate and allow secure authenticated access to infrastructure services

v.	The Solution should be capable of orchestrating compute and storage resource placements based on flexible policies to maximize hardware utilization
vi.	The Solution should be able to abstract compute, network, and storage resources for the application and user self-service regardless of hypervisor, server, network and storage hardware
vii.	The Solution should be capable of supporting multi-tenancy to run cloud services (compute, network, storage) for multiple consumers on a single platform while dynamically and automatically managing the isolation of virtual machines into secure pools. This functionality should be exposed via API
viii.	The solution must provide API reference, So as to aid in integrating with third party system.
ix.	The Solution should be able to provide workload migration, orchestration, interoperability between private and public clouds (like auto-scaling, cloud-bursting)
x.	The Solution must support standards-based REST and SOAP interfaces
xi.	The Solutions should be deployable on a wide variety of open source and proprietary host Operating Systems
xii.	The Solution should support open format
xiii.	The solution should also be able to restrict usage of each tenant to defined values, else it would lead to control over-consumption and under consumption of resources

1.2.6.2 Functional Requirement Specification(FRS) for Cloud Enablement

Server Virtualization Functional Capabilities		
1	Hypervisor	Compliant/ Non-Compliant
i.	The Virtualization software should be based on hypervisor technology which sits directly on top of Hardware (Bare Metal/Host/Embedded)	
ii.	The Solution should be able to run various operating systems like windows client, windows server, linux, solarisx86, novell netware and any other open source	
iii.	The Solution should have the capability for creating Virtual Machines templates to provision new servers	
iv.	The Solution should continuously monitor utilization across Virtual Machines and should intelligently allocate available resources among the Virtual Machines	
v.	The Virtualized Machines should be able to boot from iSCSI, FCoE and fiber channel SAN	
vi.	The Virtualized Infrastructure should be able to consume Storage across various protocols like DAS, NAS , SAN	

vii.	The Solution should allow for taking snapshots of the Virtual Machines to be able to revert back to an older state, if required	
viii.	The Solution should be able to dynamically allocate and balance computing capacity across collections of hardware resources of one physical box aggregated into one unified resource pool	
ix.	The Solution should cater for the fact that if one server fails all the resources running on that server shall be able to migrate to another set of virtual servers as available	
x.	The Solution should provide support for cluster services between Virtual Machines	
xi.	The Solution should provide patch management capabilities such that it should be able to update patches on its own hypervisor and update guest operating system through the existing EMS	
xii.	The Solution should provide the monitoring capabilities for storage, processor, network, memory so as to ensure that the most important Virtual Machines get adequate resources even in the times of congestion	
xiii.	The Solution should support Live Migration of Virtual Machine from one host (Physical Server) to another	
xiv.	The Solution should deliver above listed Hypervisor capabilities using standard server infrastructure supporting Intel/AMD OEMs	
xv.	The Solution should provide security on the hypervisor, as well as guest VMs. It should provide the ability to apply security to virtual machines and security policies that can follow the machines as they move in the cloud.	
xvi.	The Solution should provide policy-based configuration management to ensure compliance across all aspects of the datacenter infrastructure, including virtual and physical resources.	
2	Compute	
i.	The Software should have the capability to create Virtual Machines with required number of vCPUs	
ii.	The Solution should allow Virtual Machines consume RAM dynamically in such a way that if some of the VMs in Physical machine are not utilizing the RAM, this RAM can be utilized by some other VM in the same physical machine which has a requirement	
iii.	The Solution should be able to use power saving features like, in case of off-peak hours, if not all servers are required to be powered on, the	

	solution should shut down to save power	
3	Storage	
i.	The Solution should also integrate with FC,FCoE and iSCSI SAN and infrastructure from leading Vendors so as to leverage high performance shared storage to centralize Virtual Machine file storage for greater manageability, flexibility and availability	
ii.	The Solution should have the ability to thin provision disks to avoid allocating all storage space upfront	
iii.	The Solution should provide the capability to migrate the live Virtual Machine files from one storage array to another storage	
4	Network	
i.	The Solution should allow configuring each Virtual Machine with one or more virtual NICs. Each of those network interfaces can have its own IP address and even its own MAC address	
ii.	The Solution should allow for creating virtual switches that connect virtual machines	
iii.	The Solution should support configurations of 802.1 q VLANs which are compatible with standard VLAN implementations from other vendors	
iv.	Solution should take advantage of NIC Teaming Capabilities	
v.	The Solution should have the capability for moving Virtual Machines from Primary site to the Secondary site.	

Security Capability in Cloud		
1	Security Capabilities	Compliant/ Non-Compliant
i.	The Solution should offer Automated and Approval based Upgrades for Virtual Machines delivered through cloud infrastructure	
ii.	The Solution should able to extend existing malware protection solution in SDC for Virtual Machine	
iii.	The Solution should be able to provide existing Host Firewall protection for the virtual machine.	
iv.	The Solution must offer Identity, Authentication and Role based access to User Departments Infrastructure - Machines (Virtual or Physical), Application or Common Services	
v.	The Solution must offer Policy based administration by putting User	

	Departments Machines (Virtual or Physical) in logical groups and apply relevant policies.	
vi.	The Solution should have the ability to not just enforce policies but also track and report non-conformance	
vii.	The Solution should generate reports on non conformance and escalation for privileged access by unauthorized roles/ identities	
viii.	The Solution should support VLAN isolation by supporting multiple networks per resource pool	
ix.	The Solution should support secure communication between cloud framework and all target systems	
x.	The Solution must offer ability to Copy, convert, or migrate an image (P2V, V2V, V2P).	
xi.	The Solution must offer ability to utilize existing Intrusion detection System / Intrusion Protection system to seamlessly extend into Virtualization environment	

Service Provisioning Capabilities		
1	Service Portal Capabilities	Compliant/ Non-Compliant
i.	The Solution should provide a simple to use intuitive Web and experience for SDC Cloud Administrator and User Departments	
ii.	<p>The Solution should have self-service capabilities to allow Users Departments to log service requests - in SDC</p> <p>The Solution should use cloud helpdesk for logging call and maintaining escalation and in addition provide integration with existing helpdesk for maintaining record</p> <p>The Solution should be able to allow extension of the existing EMS Solutions available at the SDC to cover cloud environment (CA, HP, IBM) while permitting cloud EMS to function independently in monitoring Cloud environment required to manage cloud functionality</p>	
iii.	The Solution should be able to offer choice of various Service offering on multiple hypervisors (such as XEN , Hyper-V, VMware) with an option to	

	select multi operating systems such as Windows 2003, 2008, RHEL / SUSE Linux, etc., VLAN , Storage and quickly compute associated price for the same as well as shows the deduction for overall Tenant approved infrastructure Quota	
iv.	The Solution should offer Service catalog listing availability of Cloud infrastructure like Virtual Machines, Physical Machines, Applications , Common Services offered by State Private cloud	
v.	The Solution should provide comprehensive service catalog with capabilities for service design and lifecycle management, a web-based self-service portal for users to order and manage services	
vi.	The solution should provide an on-boarding mechanism for the new tenants (Department) on the cloud infrastructure that automatically creates the tenant, the tenant administrators, allocates specific resources for the tenant like storage pools, server pools, S/W packages, network pools (including VLANs, DNS, IP address spaces, etc...)	
vii.	The Solution should offer Registration, Signup , Forgot Password and other standard pages (Profile, Billing or Contact information)	
viii.	The Solution should enforce password policies and allow to personalize the look & feel and logo on the user-interface panels	
ix.	The Solution should be able to offer choice of various hardware profiles, custom hardware profile, Selection of operating systems, VLAN, Storage	
x.	The Solution should automate provisioning of new and changes to existing infrastructure (Virtual, Physical, Application or Common Services) with approvals	
xi.	The Solution should allow creation of library hosting various Operating System, Databases and middleware that can be selected while creating new virtual servers	
xii.	The Solution should track ownership and utilization of virtual machines, Physical machines, and common services	
xiii.	The Solution must provide the capability to support the following Service Request Types or reasons for contact: <ul style="list-style-type: none"> • Provisioning of Computing Infrastructure - Virtual, Physical or Applications • Repair (New, Cancellation, Change, Status Update) for the above infrastructure • Enquiry (New, Cancellation, Change, Status Update) 	

	<ul style="list-style-type: none"> • Customer Complaint (New, Cancellation, Change, Status Update) • Order (Feasibility, Provide, Cease, Change, Amend, Cancel, Reconnect, Status Update) 	
xiv.	The Solution should allow for implementing workflows for provisioning, deployment, decommissioning all virtual and physical assets in the cloud datacenter	
xv.	The Solution should allow easy inventory tracking all the physical & virtual assets in the Private Cloud. It should provide capabilities to track S/W licenses usage and non-compliance situations.	
xvi.	The Solution should employ Role Level Access Control with the ability to central manage Roles and Identities in an LDAP based Identity Store	
xvii.	The Solution should have the ability to manage Virtual Assets across the major multiple virtualization platforms (Microsoft, VMware, Xen)	
xviii.	The Solution should allow the ability to identify non-compliant systems (both Virtual and Physical) in terms of Desired Configuration (e.g. Lack of a Firewall or a file system policy on a VM etc.) and automatically remediate the same wherever possible	
xix.	The Solution should be able to dynamically allocate and balance computing capacity across collections of hardware resources aggregated into one unified resource pool with optional control over movement of virtual machines like restricting VMs to run on selected physical hosts.	
xx.	The Solution should have Show-Back (to check the usage patterns and reporting for the user department) and the same solution should have the capability to be updated into Charge-Back whenever this functionality is required by the SDC	
xxi.	The Solution should offer usage report by tenant, by region, or by virtual machine reporting usage of memory consumption, CPU consumption, disk consumption	
xxii.	The solution should allow the users to schedule a service creation request in a future date/time; the solution should check if a request scheduled for a future time can be fulfilled and reject the request in case of projected resources shortage or accept the request and reserve the resources for that request,	
xxiii.	The Solution should have web based interface for administration	
xxiv.	The Solution should provide quality-of-service capabilities for storage I/O so as to ensure that the most important virtual machines get adequate I/O	

	resources even in times of congestion.	
xxv.	The Solution should have the ability generate customize report as well as the native ability to export to common formats	
xxvi.	Whenever the Charge Back mechanism is enabled, the Solution must satisfy the following requirements: <ul style="list-style-type: none"> - The Solution should support different cost models like allocated or reserved cost per virtual machine. It should also allow tracking usage of resources - The Solution should allow mixing of different cost model/ policies - The Solution should have the ability to charge differently for different level of services - The Solution should support cost calculation of shared/ multi tenant application 	
xxvii.	The Solution should provide service catalog with capabilities for service offering design and lifecycle management, a self-service portal for users to order and manage services	
2	User Department Requirement	
i.	The User Departments should be able to view Department's infrastructure as Services e.g. : group his servers by- application LOB servers, All web servers, all Small servers etc	
ii.	The User Departments should be able to select between a managed infrastructure or an unmanaged infrastructure. (e.g. who will manage the Patched Updatons on virtual machines)	
iii.	The Solution should allow User Departments to delegate user services to others on their team	
iv.	The User Department should be able to allocate, monitor, report and upgrade allocated capacity	
v.	The Solution should give User Department capability to view logged, Queued , Assigned solved or Resolved queries	
vi.	The Solution should allow selecting various Operating System as well as option of Installing additional software's on the provisioned Virtual Machines to User Department while Requesting for provisioning of new virtual servers from Self service GUI	
vii.	The User Department should be able to report Department's allocated Quota, Used Quota and balance Quota of infrastructure capacity	

viii.	The User Department should be able to generate consumption reports for Department's cloud infrastructure (Virtual, Physical, Application or Common Services)	
3	SDC Private Cloud Administrator Requirement	
i.	Administrators should be able to automatically scale and/or manage resources unilaterally (as also termed in the NIST definition) for tenant services without manual intervention as and when required by the SLA requirements of the service	
ii.	The Cloud Automation framework should provide capability for Role based Access for performing specific tasks	
iii.	Private Cloud Administrators should be able to easily configure, deploy, and manage services through a highly intuitive service-centric interface, while using a library of standard templates	
iv.	Private Cloud Administrators should be easily be able to take resources offline and online	
v.	Private Cloud Administrators/Application Owners should be able to create, manage, services using a web-based interface that presents a customized view of resources based on your role in the organization	
4	Capacity Management	
i.	The Solution should be able to determine how many more virtual machines can fit the environment	
ii.	The Solution should identify idle, underutilized capacity to provide inputs to the capacity management function such that informed decisions can be taken	
iii.	The Solution should support to identify and determine optimum sizing and placement of virtual machines	
iv.	The Solution should provide forecast reports demonstrating forecasted utilization	
v.	The Solution should support all of the following modeling scenarios: Physical to Virtual, Virtual to Virtual, Virtual to Physical, Virtual to SDC private Cloud, and Test to Production	
vi.	The Solution should provide a mechanism to automatically assess high volumes of workloads and determines optimal placement on virtual machines across the enterprise's shared resource pools	
vii.	The Solution should be able to utilize existing investment in tools/	

	Functionality and extend these to virtual environment as well, which are available from leading vendors like BMC, CA, IBM, HP and Microsoft	
--	---	--

Automation, Orchestration and Monitoring

Process Automation

The Solution should demonstrate a way to comprehensively model cloud datacenter process end to end across multiple Vendors software and hardware thus enforcing Operational Best Practices and Procedures
The Solution should be integrated to existing ITIL Service Support Areas functions including but not restricted to Event Management, Incident Management, Request fulfillment, Problem Management, Access Management
The Solution should allow automating best practices, such as those found in Information Technology Infrastructure Library (ITIL) through workflow processes that coordinate management tools to automate incident response, change and compliance, and service-lifecycle management processes
The Solution should have capabilities to create workflows to automate common admin challenges
The Solution should have the ability to develop highly customized workflows and easy user interface.
The Solution should have web based interface

2	Integration Capabilities	
i.	The Solution should be able to create processes across multiple vendors' software and hardware	
ii.	The Orchestration Solution should be open and interoperable and has rich integration capabilities that support interfaces from command line interface and web services	
iii.	The Solution should be capable of extending entire functionality to virtual environment utilizing existing components of SDC such as Enterprise Management System (EMS)	
iv.	The Solution should provide resource-level operations across compute resources, hypervisors (VMware, Xen, Hyper-V), storage resources and network resources. It should support provisioning for multiple platforms including Windows, Linux, & ESX on x86 (32 and 64 bit)	
v.	The Virtual Machine should be able to be monitored from the existing EMS solution available in SDC	
vi.	The Solution should provide capability for orchestrating tasks across systems for consistent, documented, compliant activity.	

vii.	The Solution should possess capabilities to extent resource & cloud fabric management onto other Private Clouds	
viii.	The Solution should be able to move identified workloads to another private cloud	
ix.	The Solution should be able to audit and monitor execution of processes and report on violations against the same	
x.	The various participating HW & SW components in the Data Center process as modeled by the solution should be easily manageable by this Orchestration layer	
xi.	The Solution should provide a set of adapters that should be able to utilize existing infrastructure elements and IT service management tools to provide smooth, precise orchestration of automated processes	
xii.	The Solution should be able to accelerate adequate utilization of subsystems (not limited to but including) the backup solution, the service manager/helpdesk module, the operations modules, the virtual asset provisioning modules etc	

3	Monitoring Capabilities	
i.	The Solution should be able to monitor User Department Virtual Resources independent of the platform & solution/service they are running	
ii.	The Solution should be able to monitor key performance characteristics of the virtual resource (OS, RDBMS, Memory, Storage, Network etc.)	
iii.	The Solution should monitor all the critical operating system level services and should check for their status like running, not running, paused. In addition, deviations from a defined Configuration should be detectable and reported	
iv.	The Solution should give User Department ability to select performance counters and duration for which they want to view the performance data	
v.	The Solution should have the mechanism to store the historical data for problem diagnosis, trend and analysis	
vi.	The Service level dashboard provided with the Solution should have a web based interface	
vii.	The Solution should be able to send the reports through e-mail to predefined user with pre-defined interval	

viii.	The Solution should be able provide integration with the existing helpdesk system for incidents in SDC	
ix.	The Solution should trigger automated actions based on incoming events / alerts	
x.	The Solution should provide a Knowledge base to store history of useful incident resolution	

1.2.7 Security Components

Functional Requirement for Data Loss Prevention

S No		Compliance
1	The solution shall be able to discover, classify, monitor and protect data.	
2	Overall the solution shall provide a central point of control and management for all its components. The discovery and classification shall be based on various identification mechanisms including regular expressions, keywords and phrases, dictionaries, re-usable entities using programmatic validation logic to detect patterns, full and partial fingerprinting, and proximity analysis using weightage as well counting of detected parameters.	
3	Should provide a single DLP solution management and policy creation interface for DLP components –endpoints. The product shall come with pre-defined policies which should be editable and also could be used to create new ones.	
4	The solution shall have a dashboard showing details of the current activity within the organization from the DLP point of view. The DLP system should be able to provide detailed view of each of the components in the DLP systems like the agent scanning status, detection point status, incident status etc. The dashboard should be completely customizable and the solution should also able to provide a different dashboard for each user with login privileges, as per his / her preferences or roles.	
5	The solution shall have extensive reporting and auditing capabilities. The solution should also provide out of box options to integrate with external Security and Incident Management system as well as provide customized reports and notifications.	
6	The solution shall provide incident notification as well as escalation workflows for unattended incidents.	
9	The solution should be able to highlight the violated content within the incident for clear identification and resolution of the incident.	
10	The solution should be able to provide identity information on the sender (such as full name, manager name, business unit). This should be accomplished across all incidents email, non-email, storage as well as endpoint.	
11	Different actions should be configurable based on the user context and risk level associated with a particular data match - the risk levels too should be configurable based on the risk score calculated.	

Functional Requirement for Security Incident Management

S No		Compliance
1	The solution should offer Single View of All the Data captured from devices across sites/geographies.	
2	The solution should be able to collect raw logs in real-time to a Central log database from any IP Device including: <ul style="list-style-type: none"> • Networking devices(router/switches/voice gateways) • Security devices (IDS/IPS,AV,Patch Mgmt, Firewall/DB Security solutions) • Operating systems(Windows 2003/2008,Unix,linux,AIX) • Main frames(IBM etc) • Virtualization Platforms(Microsoft HyperV, VMware Vcenter/VSphere 4.X) • Databases(Oracle/SQL/MYSQL/DB2) Note : For detail technical specifications please refer section 1.2.3.5 for IPS & 1.2.3.6 for End Point Protection for Servers and PCs (HIDS/ HIPS)	
3	The solution should be able to collect the logs in an agent/ agent less manner and store the same in real-time to a Central log database from any IP Device. The logs should be time stamped, compressed to optimize storage utilization.	
4	The solution should collect the entire log sent by the devices. This will help in maintaining digital chain of custody. These logs can be modified by a malicious indented user. In order to make these logs tamper proof solution must store events in compressed archives that are temper proof encoded.	
5	The solution should provide tools for developing collection and parsing capabilities for home-grown or any other unsupported /unknown IP applications.	
8	The system should provide for integration with third party ticketing systems for escalated incidents that need escalation.	
9	The tool should provide flexible dashboard interface customized to user preferences allowing the examination of a specific event or a holistic view of the systems within the enterprise.	
10	The tool should have the capability to fetch logs from the solution in real time or desired period (hours/days/specific period etc) to ensure comprehensive trend and historical analysis and reporting.	
11	The solution should allow filtering log data based on log message payload like source and destination ip, ports, usernames, workstation address, domain etc.	
12	The Solution must provide remediation of the incidents by prioritizing incidents based upon the security policies and generating tickets for a quick response to security threats associated with the affected assets. It should also be track these changes.	

Functional Requirement for Policy Management

S No		Compliance
1	Policy management security control would aim to identify the issues and help define and build a strong foundation for corporate wide Governance risk and compliance framework	

S No		Compliance
2	The framework should provide a centralized infrastructure for creating policies, standards and control procedures and mapping them to objectives, regulations, industry guidelines and best practices	
3	The framework should also enable SDC to communicate policies across its user base, track acceptance, assess comprehension and manage valid exceptions	
4	The Policy Management framework should allow to grant or deny exception requests based on the value of the control standard to SDC corporate objectives and governance program	
5	The framework should also allow reporting on exceptions across the enterprise, monitoring them by control, department, severity or other meaningful criteria	
6	Should provide the capability to demonstrate compliance in an efficient and cost-effective manner and must be able to automate processes wherever possible, reduce duplication of effort and quickly react to deficiencies identified in the assessment process	
7	<p>The compliance management solution should allow SDC to achieve at a minimum the following:</p> <ul style="list-style-type: none"> - Document control procedures and test plans, mapping them to applicable control standards, regulations, business units, risks, business processes and technologies. - Determine which controls need to be tested for a given assessment criteria. - Perform continuous controls monitoring by capturing the results of automated configuration checks. - Auto-generate deficiencies for non-compliant control activities, and map those findings to policies, regulations and risks. - Route findings to appropriate personnel, who can resolve them through remediation tasks or exception requests. - Form a consolidated picture of compliance efforts and remediation processes through reports and dashboards. 	
8	The process should be supported by a solution that can deliver a central management system for identifying risks, evaluating their likelihood and impact, relating them to mitigating controls and tracking their resolution.	
9	Reports should detail compliance adherence to security policy in SDC. Data being of prime importance to the SDC, compliance reports should pick incidents from data loss and store in the database. This data can be used to check for the adherence to data loss policy along with other security violations	
10	This solution should be able to provide the tools to implement SDC's unique enterprise risk management methodology—automating, streamlining, exception handling, measuring and reporting at every step of the process.	

S No		Compliance
11	<p>The risk management process would provide SDC the capability to provide</p> <ul style="list-style-type: none"> - A registry of potential risks, and relates them to corporate objectives, key risk indicators and mitigating controls. - Maintain a repository of qualitative, quantitative and trending metrics, and automate the collection of supporting data. - Calculate inherent and residual risk automatically based on assessment scores and risk mitigation. - Generate real-time reports and executive dashboards, providing clear visibility into key risk indicators, the status of assessment efforts and your organization's overall risk profile. - Integrated management and reporting of risk management data and processes with the compliance management process to achieve efficiency and transparency enterprise-wide. 	

TECHNICAL SPECIFICATIONS PACKAGE – CIVIL & INTERIOR WORKS

1.3 SDC Architecture – Physical Infrastructure

1.3.1.1 Layout of Data Centre

Entire SDC area is logically divided in Zones based on MIT guidelines. Each of these zones are having different objective described further in this section. The respective area of each Zone would actually vary, primarily on the basis of number of applications and Size of the State. Total SDC area for the Data Centre of Punjab is nearly 4000 sq. ft. The site is proposed to be in Mohali. SDC is proposed to be on first floor of the building.

Zone A - This DC Server room area would host servers, server racks, storage racks and Networking component. The area required for Zone A should approximately be 1500 sq. ft, This has to include the staging area.

Zone B - Comprises of NOC room (16'.0"X15'.9"), reception area, Help Desk area, BMS Area (11'.0"X11'.0"), Testing /Monitoring room, staging and reception, DC manager area, DC operation and media storage room.. This zone requires approximately 1500 sq. ft

Zone C - Comprises of room for power panels, UPS and other power equipments (900 sqft). This zone requires approximately 1000 sq. ft.

A revised Layout plan have been included in the RFP indicating individual sizes as sent to DIT earlier along with RFP assessment framework.

1.3.1.2 Technical Specifications – Civil and Interior Work

i. **Demolition Work – Since this is a new building**, demolition work is not required. In case some amount of demolition is required then DCO should take enough care not to make heavy noises that disturb other areas in the building. Any damage done to the structure or other area to be borne by the DCO. The DCO has to get permission from SIA before start of dismantling. Cutting of reinforcement in any element for the building shall not be carried out without prior permission of the SIA. The debris accumulated due to dismantling has to be disposed in an area that is far from the area as directed by the SIA. There will be no accumulation of debris in the SDC vicinity for more than 12 hours.

ii. **PEST CONTROL**

Pest control treatment for the facility has to be done in accordance to the guideline laid as per IS 633 part II.

iii. **TRENCH WORKS**

Trenches may be required for cables to run from the DG area to the SDC electrical room. The bed of the trench shall be even throughout. The trench has to be filled by lime concrete or sand as directed by SIA. Trench walls to be made on hard bricks. There has to be service pits on the length of the trench properly covered. These covers are to be openable and have sufficient strength so that it does not get damaged. Care to be taken for not making any damage to the existing pipes, drains, cables. Any damage done has to be borne by the DCO.

iv. **MASONRY WORKS**

Brick Work:

a. All brick work should be carried out as per approved drawings mutually agreed between the consultants, SIA and DCO. The brick work shall be done as per the norms laid down by CPWD. The bricks (table molded) shall conform to IS 1077. Other country bricks shall be approved by the SIA. Proper curing has to be done for all the brick walls. Brick work is not envisaged inside the DC area. However it may be required for the DG area. The DCO has to create a DG shed so as to protect the DG from sun and rain. The DG platform to be raised over the ground so that water does not enter the DG. The fuel tank has to be mounted in similar fashion.

v. Plastering

The requirement of plaster work if required shall be to provided absolutely water tight enclosure, dense, smooth and hard and devoid of any cracks on the interior or exterior. Masonry and concrete surfaces, which call for applications of plaster, shall be clean, damp and sufficiently rough and keyed to ensure proper bond, subject to the approval of the SIA.

vi. Water Proofing

Water proofing wherever required has to be done by the DCO as per the direction of SIA and in accordance to the existing IS standard or as per CPWD norms.

vii. Laying of Vitrified Tile Flooring:

The vitrified tiles shall be selected by SIA and DCO mutually. Necessary edge, hole cutting and chamfering and miter joints shall be done wherever required. The finished material shall be protected against wear and tear and other works using heavy duty PVC sheets and 40mm thick Plaster of Paris. This shall be cleared with acid as soon as the place is ready for occupation. This shall be removed as soon as the related interior works are over.

viii. Granite wall cladding :

Granite wall cladding using 19mm thick pre polished slab as per the SIAs specs fixed to the wall surface by means of 1:3 cement mortar used as a bonding agent, necessary clamps, screws and cement grout. The vertical and horizontal joints between each panel of granite should have groove (as per SIAs details). Necessary edge and hole cutting, chamfering and granite joints shall be filled with cement paste mixed with pigment to match the colour of the granite. The finished granite surface shall be protected against wear and tear by cladding it with PVC sheet and gum tape. The final surface shall be granite polish by machine. The pricing shall include hacking the existing wall or other places. All edge chamfers / cutting of granite shall be mirror polished and no extra shall be paid for the same.

ix. Hardware And Metals

The hardware throughout shall be of superior quality. The DCO may be required to produce and provide samples from many different sources before the Consultant/SIA. Fitting generally shall be brass oxidized, unless otherwise specified and shall be suitable for their intended purpose. In any case, it will have to be approved by the SIA before the DCO procures it at the site of work.

Screws are to match the finish of the article to be fixed, and to be round or flat headed or counter sunk as required. The DCO should cover up and protect the metal surfaces such as brass, bronze, SS etc. with a thick grease or other suitable protective material, renew as necessary and subsequently clean off and clear away on completion.

Aluminum and stainless steel shall be of approved manufacture and suitable for its particular application. Generally the surface of aluminum shall have an anodized finish and both shall comply with the samples approved by the SIA. All steel, brass, bronze, aluminum and stainless steel articles shall be subjected to a reasonable test for strength, if so required by the SIA at the DCO's expense.

x. Glazier

All glass to be complying with IS 1548-1966. The compound for glazing to metal is to be a special non-hardening compound manufactured for the purpose and of a brand and quality approved by the SIA. All fire rated glass will be clear glass and with or without wire mesh. Fire rating of glass to be 60 minutes.

xi. Paint

Providing and applying fire retardant paint of approved make and shade to give an even shade over a primer coat as per manufacturers' recommendations after applying painting putty to level and plumb and finishing with 2 coats of fire retardant paint. Base coating shall be as per manufacturer's recommendation for coverage of paint.

For all vertical Plain surface.

For fireline gyp-board ceiling.

Providing and laying POP punning over cement plaster in perfect line and level with thickness of 10 - 12 mm including making good chases, grooves, edge banding, scaffolding pockets etc.

Applying approved fire retardant coating on all vertical surfaces, furniture etc. as per manufacturer's specification.

xii. Upholstery

This may be required for the reception area of the SDC. This will be of first class standard workmanship with webbing, no sag springs, coiled springs, padding and filling as specified on drawing. Covering fabrics will be soon tufted and corded as approved by the SIA.

xiii. Plywood/ MDF Boards

Plywood/ medium density fiberboard/ blackboard/ teak particleboard/ veneered board, etc. As specified in the approved list of manufacturers shall only be used. Only B.W.P grade phenol formaldehyde bonded hot pressed plywood generally conforming to I.S.I 303 of approved make shall only to be used. Marine plywood shall generally conform to I.S. 710-1980. Blockboard shall be equal or superior quality as per B.S. 3444

xiv. Laminates

Laminates where specified shall be of approved brand, type, texture and thickness and manufactured as per IS: 2046 –1969. Fixing of laminates shall be done as per best trade practices and strictly as per printed instructions of the manufacturers using Phenol Formaldehyde Synthetic Resin Adhesive of approved make.

xv. False Flooring

The datacenter should have raise flooring on the area where IT equipment such as Server racks, storage network racks are placed. The height of the raise floor to be 450 mm from the real floor. The following specifications for the raise flooring may be adhered. Vendor to Quote for product that is either meet the following specs or higher.

A: Mandatory Structural Parameters

Concentrated Loads :

540 Kgs (1200 lbf) with a top-surface deflection under load and a permanent set not to exceed , respectively, 2.54 & 0.25 mm (0.10 & 0.010 inch)

Ultimate Concentrated Load:

1350 Kgs (3000 lbf)

Rolling Loads :

270 kgs (600 lbf) of the following magnitude, with a combination of local and overall deformation not to exceed 1.02 mm (0.040 inch)

Stringer Load Testing :

204 Kgs (450 lbf) at the centre of the span with a permanent set not to exceed 0.25mm (0.010 inch)

Pedestal Axial Load Test :

22 Kn axial Load per pedestal

B : Other Optional Structural Parameters :

Floor Panel Impact – Load Performance :

100 lbf when dropped from 36 inches (914 mm) on to 1-Sq.Inch (6.5 sq.cm) area located anywhere on Panel without failing.

Uniformly Distributed Load (UDL):

1620 kg/m² with a maximum permissible deflection of not more than 1.52 mm tested over an area of 300x300 mm square for 100kgs load

C : Other Non structural Parameters :

Fire Rating :

The Panels shall confirm to Class O & Class 1 Fire Ratings tested as per BS 476 Part 6 (Fire Propagation) & 7 (Surface spread of flame) as also ASTM E84 1998 (Flammability) and ASTM E136 (Combustibility)

Electrical Resistivity :

As per ASTM F150/ NFPA 99 / ANSI S7.1 but modified for surface to ground to place one electrode on the floor surface and to attach the other electrode on the pedestal.

xvi. Modular ceiling Tile

Providing and fixing of Mineral Fiber Ceiling tiles in true horizontal level false ceiling grid. Using hot dipped galvanized steel section, exposed surface chemically cleaned capping prefinished in baked polyester powder paint, Main tee of size 15 x 35 x 0.33 mm at every 1200 mm C/C max and rotary stitched cross tee of size 15 x 30 x 0.33mm at every 600 mm C/C 0.457 mm wall angle around the wall to form a grid of 600 mm x 600 mm and suspending the grid using 2 mm GI rod and 6 mm rawl plug at every 1200 mm intervals at the main tee and laying the Ceiling tiles of size 595 mm x 595 mm x 15 mm over the formed grid having fire rating of 60 minutes as per BS 476/23 of 1987, Noise reduction Coefficient (NRC) of 0.50-0.60, to resist temperature and humidity conditions up to 40degree (104deg. F) and humidity of 95% RH, Weight of 3.5Kgs/SQ.M.

xvii. Gypsum Ceiling

Suspended gypsum board false ceiling of G.I.Channel grid type framework, gypsum boards, paper tape, gypsum putty and cutouts for light fittings, A/C grills, and Fire Alarm accessories has to be provided by the DCO in the area wherever required as per mutually agreed and approved drawing. The gypsum board panels 12 mm thick are secured on to bottom of the frame work by means of screws. Necessary cutouts for lights, detectors and other ceiling mounted equipment needs to be provided. The surface of the ceiling must be smooth. Plastic emulsion paint to be done on the gypsum ceiling.

xviii. Record protection equipment – Fire proof cabinets**Features:**

Computer Grey, Polyurethane (PU) paint.

sizes -300 ltrs.

Protects from fire, dust, heat, moisture, magnetic fields, electrostatics and accidental damage.

Designed to withstand temperatures up to 1000 degree C for over an hour.

Average Internal temperature below 30 degrees C after 60 minutes of testing in furnace.

Average internal temperature below 44 degree C after a 6-hour soak out period.

Adjustable shelves and pull out trays should be available

Locking system

Two 10- lever high security Cylindrical Locks.

Snap shut mechanism.

The safe has to be as per IS:14562 for 1 hr. Fire endurance and 1 hr. Fire & Impact Test.

1.3.1.2.1 Modes of Measurement

1.	Walls, Partitions, main wall	Elevational Area (volumetric)
2.	Flooring	Plan area between skirting
3.	Skirting	Running length
4.	Windows	Elevational Area (including frame)
5.	False Ceiling	Actual Area between partitions (Rate shall be inclusive of making holes/ cutouts / openings for light fittings, AC grills, Smoke Detectors, Sprinklers, provision of perimeter channel for support/fixing of grills / light fittings and suitable boards of 300 x 300 x 10mm for spotlights. No deductions shall be made for any such cutouts/opening). However, column areas shall be deductible.
6.	Partition	Elevational Area (From finished floor/false floor level to finished false ceiling level).
7.	Wall Paneling	Elevational Area

8.	Workstations	Nos.
9.	Tables	Nos.
10.	Rear/Side Credenzas	Elevational Area
11.	Utility/Staff counters	Running length
12.	High/Low Storages	Elevational Area
13.	Storage above counter	Elevational Area
14.	Door/Frames	Nos.
15.	Rolling Shutters/Collapsible gate	Elevational Area
16.	Shutters for ducts and below window cill	Elevational Area
17.	Blinds	Elevational Area
18.	Grills	Actual surface area
19.	Pest Control / Anti-termite treatment	Carpet floor area, plan area

Note: Measurements shall be recorded upto three digits after decimal point

Note:

All material to be used shall be of first quality unless otherwise specified.
 All sizes of materials mentioned shall be finished sizes.
 All materials used shall be of I.S.I grade wherever applicable.

Important conditions:

- All types of shop/ coordinated/ elevation/ working/ Good for construction drawing has to be submitted to the SIA and without the approval of the SIA no work will be executed.
- Data sheet/ Catalogues/ brochures of the material have to be submitted before use.
- The vendor has to get the sample of each item approved from the SIA before using for construction
- The sample required any test as per the direction of SIA the cost of sample and testing will be borne by the bidder. Test lab will be decided by SIA.
- Quantity mentioned in the BOQ is approximate. Bidders need to visit the site and assess the quantities before quoting.

1.3.1.3 Technical Specifications – Electrical

1.3.1.3.1 UPS, Batteries and Accessories

Purpose

The purpose of this specification is to define the design, manufacture and testing characteristics required in view of supplying, putting into operation and maintaining an Uninterruptible Power Supply system (referred to as a UPS in the rest of this document). The UPS system shall be designed to supply dependable electric power to:

The total load supplied by the UPS system shall be equal to 250kVA, at a load power factor pf greater than 0.9.

Brief description

There will be 2 UPS system of 250KVA each in each BUS of the LT Panel. Each set of UPS in a BUS will have separate battery banks for 30 minutes backup on each on full load UPS units (same power rating), operating in double-conversion mode (also called on-line mode); it shall be a VFI-type UPS (as per standard IEC 62040-2).and shall comprise the following components, described below in this specification:

- 6 pulse/12 Pulse/PWM rectifier with active/passive filter (if required)
- battery charger;
- inverter;
- battery;
- static bypass (via a static switch) for each UPS unit; manual maintenance bypass for each UPS unit user and communications interface;
- battery management system;
- any and all other devices required for safe operation and maintenance, including circuit breakers, switches, etc.

The UPS system shall ensure continuity of electric power to the load within the specified tolerances, without interruption upon failure or deterioration of the normal AC source (utility power) for a maximum protection time determined by the capacity of the backup batteries installed.

Operating principle

Each double-conversion UPS unit (also called on-line) shall operate as defined below.

i. Normal operation

The rectifier shall supply the corresponding inverter with DC current while the charger simultaneously float charges its battery. The load is continuously supplied with dependable electrical power by the inverter.

ii. Operation on battery power

Upon failure or excessive deterioration of the normal AC source, the inverter shall continue to supply the load with power from its battery without interruption or disturbance, within the limits imposed by the specified battery backup time.

iii. Battery recharge

When the normal AC source is restored, the rectifier shall again power the corresponding inverter, without interruption or disturbance to the load, while the charger automatically recharges the battery.

iv. Load sharing operation and redundancy

The units shall operate in load sharing mode with redundancy, with the load shared equally between the units.

Redundancy shall be of the "n+n" type, i.e. "both the UPS will work independently but synchronized for voltage, and frequency through load bus synchronization technology . In case of failure of one UPS the load will be transferred to the other one without affecting or creating any disturbance to the load.

v. Transfer to bypass AC source

In the event of an overload exceeding system capabilities (short-circuits, heavy inrush currents, etc.) the load shall be automatically transferred, instantaneously and without interruption, to the bypass AC source, on the condition that bypass power is available and within tolerances.

To that end, synchronisation of each inverter in phase and frequency with the bypass source shall be automatic. Transfer of the load back to the UPS-unit outputs shall be automatic or manual. During transfer, the load shall not suffer an outage or disturbance in the supply of power.

To ensure transfer in complete safety, the system shall close simultaneously the static switches.

On request, the UPS system may automatically transfer the load with a micro-interruption if a major fault occurs on the UPS system and if synchronisation with the bypass source has not been established.

The above feature is required but may not be necessarily in force as it is not expected or desirable to feed unconditioned power to the SDC through bypass line.

vi. Maintenance on UPS units

For maintenance purposes, all electronic components shall be accessible from the front of the UPS. In addition, a built-in manually-operated mechanical bypass system shall be:

Installed in each UPS unit; Installed separately in an external bypass enclosure or cubicle

For personnel safety during servicing or testing, this system shall be designed to isolate the UPS units while continuing to supply power to the load from the bypass AC source. Transfer to the manual bypass mode and back shall be possible without interruption to the load.

The UPS shall also include a device making it possible to isolate the rectifiers and the chargers from the normal AC source.

vii. Battery maintenance

For safe maintenance on the battery of each UPS unit, the system shall include a circuit breaker to isolate the battery from the corresponding rectifier/charger and inverter.

When the battery is isolated from the system, the UPS shall continue to supply the load without interruption or disturbance, except in the event of a normal AC source outage.

Sizing and general characteristics

i. Technology

The UPS shall be based on double conversion SCR/PWM rectifier and IGBT Inverter technology with built-in thermal monitoring and a high free-frequency chopping mode to dynamically optimise efficiency and power quality.

RatingThe UPS system shall be sized to continuously supply a load of 80 kVA (min), at a load power factor (pf) of 0.9. It shall be made up of 2 UPS units in each BUS, each with an identical rating of 80 KVA.

ii. Battery backup time

The backup time of each battery in the event of a normal AC source outage shall be 30 minutes per UPS (min 80KVA load with 0.9 load pf of resistive load)

The service life of each battery shall be equal to at least 15 years.

Batteries shall be selected and sized accordingly.

iii. Reliability and MTBF

The UPS has to be highly reliable with a high MTBF

iv. Types of loads accepted

If all the connected loads are non-linear (100% non-linear loads), each UPS unit shall accept high crest factors (3:1) without derating of output.

For both linear and non-linear loads, the voltage total harmonic distortion at UPS output (THDU downstream) shall respect the following limits:

- THDU downstream ph/ph and ph/N \leq 3% for linear loads;
- THDU downstream ph/ph and ph/N \leq 5% for non-linear loads.

v. Limitation of harmonics upstream of the UPS system

The UPS system shall not draw a level of harmonic currents that could disturb the upstream AC system, i.e. it shall comply with the stipulations of guide IEC 61000-3-4 (formerly IEC 1000 3-4).

In particular, the UPS shall respect the following characteristics at the normal AC input: total harmonic current distortion (THDI) upstream of the rectifier not exceeding:

1. 7% at full rated load for an computer grade load
2. input power factor (pf) greater than or equal to 0.92.

To achieve the above use of different kinds of rectifier, active or passive filters are acceptable. However the foot print of the UPS due to this should not vary by more than 15%.

These performance levels, due to the "clean" input rectifier drawing sinusoidal current, limit upstream distortion and avoid oversizing of upstream equipment (cables, circuit breakers, etc.), without requiring additional filters.

vi. Efficiency

Overall efficiency of each UPS unit shall be greater than or equal to:

- 92% at full rated load in normal mode;
- 90% at 50% rated load in normal mode;
- 85% at quarter rated load

vii. Noise level

The noise level, measured as per standard ISO 3746, shall for each unit be less than:

- 72 dBA.

AC sources

The UPS system shall be designed to receive power from the sources presented below.

i. **Normal AC source** (rectifier input)

The normal AC source supplying the UPS shall, under normal operating conditions, have the following characteristics:

- rated voltage: 415V +10%, -15% at all load conditions
- number of phases: 3 ph + earth. The neutral may or may not be necessary.
- frequency: 50 Hz \pm 6%.

ii. **Bypass AC source**

(static-bypass input, if separate from rectifier input)

The bypass AC source shall continue to supply the load, without interruption, if its characteristics remain within voltage tolerances

Outside these tolerances, it shall be possible to supply the load, but in downgraded mode.

Electrical characteristics

I. **Rectifiers and chargers**

i. **Supply**

The rectifier and charger module shall be supplied via the normal AC input. It must be capable of operating without a neutral

ii. **Inrush current**

A device shall be provided to limit inrush currents.

iii. **Battery-current limiting**

For long battery life, an electronic device shall automatically limit the charging current to the maximum value specified by the battery supplier

iv. **Voltage regulation**

Rectifier/charger regulation on each unit shall take into account the ambient temperature of the battery and shall ensure DC output voltage fluctuations of less than 1% irrespective of load and AC input voltage variations

II. **Batteries**

The UPS system batteries shall be 2 Volt, Sealed, lead acid, valve regulated, heavy duty type having design float life of 15 years , sized considering end cell voltage of 1.75 Volts per cell 30 Minutes discharge.

Bidder has to submit detailed battery backup calculation duly authenticated by battery manufacturers.

III. Inverters

Each inverter shall be sized to supply a load rated 250 KVA at a load power factor (pf) of 0.9, taking into account the characteristics presented below.

i. Output voltage

- Rated voltage:[380 / 400 / 415] volts rms, adjustable via the user interface, within tolerances of +/- 3%.
- Number of phases: 3 phases + neutral + earth.
- Steady-state conditions: The variation in the rated voltage shall be limited to $\pm 2\%$ for a balanced load between 0 and 100% of the rated power, irrespective of normal AC input and DC voltage levels.
- Voltage variations for load step changes: Output voltage transients shall not exceed $\pm 5\%$ of rated voltage for 0 to 100% or 100 to 0% step loads. In all cases, the voltage shall return to within steady-state tolerances in less than 50 milliseconds.
- Unbalanced load conditions: For a 100% load unbalance, the voltage unbalance shall be less than 2% in phase-to-neutral amplitude.

ii. Output frequency

- Rated frequency: 50 Hz.
- Variations :- ± 0.5 Hz,

iii. Synchronisation with bypass power

- When bypass power is within tolerances

To enable transfer to bypass power, the inverter output voltage shall be synchronised with the bypass source voltage whenever possible. To that end, during normal operation, a synchronisation system shall automatically limit the phase deviation between the voltages to 3 degrees, if the bypass frequency is sufficiently stable (within adjustable tolerances of $\pm 0.5\%$ to $\pm 8\%$ with respect to the rated frequency).

- Synchronisation with an external source

It shall be possible to synchronise with all types of external source.

For example, if the bypass source is a generator set, the synchronisation tolerances shall be approximately $\pm 0.5\%$ to $\pm 8\%$ (adjustable) with respect to the rated frequency.

- Autonomous operation following loss of synchronisation with bypass power

When the bypass source frequency deviates beyond these limits, the inverter shall switch over to free-running mode with internal synchronisation, regulating its own

frequency to within $\pm 0,001\text{Hz}$. When bypass power returns to within tolerances, the inverter shall automatically resynchronise.

- Variation in frequency per unit time

During the switch to free-running mode and the switch back to synchronised mode, frequency variations per unit time (dF/dt) shall be limited to 1 Hz/s or 2 Hz/s (user defined).

iv. Overload capacity

The UPS shall be capable of supplying for at least:

- 10 minute a load representing 125% of the rated load;
- 60 second a load representing 150% of the rated load.

IV. Static-bypass

I. Static bypass

Each UPS unit shall be equipped with a static bypass comprising a static switch. The static bypasses shall be controlled simultaneously by a built-in system. Instantaneous transfer of the load from the inverters to bypass power and back shall take place without a break or disturbance in the supply of power to the load, on the condition that the bypass source voltage and frequency are within the tolerances and that the inverters are synchronised.

Transfer shall take place automatically in the event of a major overload or an internal inverter fault.

Manually initiated transfer shall also be possible.

II. Static-switch protection

Each static switch shall be equipped with an RC filter for protection against switching overvoltages and lightning strikes.

III. Discrimination and short-circuit capacity

If the bypass power is within the tolerances specified, the presence of the static switch shall make it possible to use the short-circuit power of the bypass source to trip the downstream protection devices of the common inverter output.

V. Mechanical characteristics

I. Mechanical structure

The UPS and batteries shall be installed in cabinet(s) with a degree of protection IP20 (standard IEC 60529). Access to the subassemblies making up the system shall be exclusively through the front.

II. Dimensions

The UPS shall require as little floor space as possible. To gain space, it shall be possible to install the UPS with the back to the wall. However, space in the back can be given based on technical requirement. The ratio between the floor print and weight will be a criterion for selecting the product/ brand. It should be as low as possible.

III. Connection

To facilitate connections, all terminal blocks must be easily accessible from the front when the UPS is installed with the back to the wall. Entry of upstream and downstream power cables, as well as any auxiliary cables, shall be possible through the bottom for a false floor.

The neutral conductor shall be oversized for any third-order harmonic currents and their multiples (the size of the neutral shall be 1.5 times that of each phase).

IV. Safety

The equipment shall meet the requirements of degree of protection index IP21, in compliance with standard IEC 60529.

For the safety of maintenance personnel, the cabinet shall be provided with a manually operated mechanical bypass designed to isolate the rectifier, charger, inverter and static switch while continuing to supply the load from the bypass AC source.

It shall be possible to send to the UPS an external EPO order resulting in opening of the battery circuit breaker and the upstream circuit breaker.

VI. Environment conditions

I. UPS (not including batteries)

i. Operation

The UPS shall be capable of operating under the following environmental conditions without loss of performance:

- ambient temperature range: 0° C to +40° C;
- recommended temperature range: +20° C to + 25° C;
- maximum relative humidity: 95% at 25° C;
- maximum altitude without derating: 1000 meters.

ii. Storage

The UPS, not including the battery, shall be designed for storage under the following conditions:

- ambient temperature range: -10° C to +45° C.

VII. Protection

I. UPS

Each UPS unit shall include protection against AC-source overvoltages (as per standard IEC 60146), excessive external or internal temperature rise and vibrations and impacts during transport.

II. Rectifier and charger

The rectifier and charger shall automatically shut down if the DC voltage reaches the maximum value specified by the battery manufacturer or if the temperature exceeds the limits specified above.

III. Inverter

Inverters shall self-protect against overloads and short-circuits, irrespective of the operating mode (AC power or battery power). There has to be a inbuilt Isolation transformer of full capacity at the output of inverter for galvanic isolation.

IV. Batteries

i. Protection against deep discharge and self-discharge

The UPS shall comprise a device designed to protect the battery against deep discharges, taking into account the characteristics of the discharge cycles, with isolation of the battery by a circuit breaker.

ii. Independent regulation and monitoring systems

A regulation system shall regulate the battery voltage and the charge current.

A second system, independent of the regulation, shall monitor the battery voltage and the charge current. Consequently, if the regulation system fails, the monitoring system steps in to shut down the charger and avoid overcharging.

iii. Regulation of the battery voltage depending on the ambient temperature

A temperature sensor adapts the charge voltage to the ambient temperature.

This regulation system takes into account the chemical reaction and prolongs the battery service life.

The permissible temperature range is set in the personalisation parameters.

An alarm shall be issued for temperatures outside the permissible range.

iv. Self-test

Battery monitoring shall be carried out by an automatic device. Self-test intervals shall be set to one month by default, but shall be adjustable.

This self-test system shall, where necessary, initiate indications via LEDs on the front panel or a message to a remote monitoring system.

v. Possibility of battery circuit-breaker management

Each UPS unit shall be capable of receiving and managing two battery circuit breakers. Battery availability is improved by dividing it into two sections. If one section is faulty, the second shall remain available and provide approximately half of the backup time.

VIII. Battery Management

I. Battery meter

The battery-meter function estimates the available backup time of the UPS as a function of the battery charge and the percent load.

II. Digital battery monitoring

The UPS shall be equipped with a system for battery digital management.

Based on a number of parameters (percent load, temperature, battery type and age), the system shall control the battery charge voltage and continuously calculate:

- The true available backup time
- The remaining service life.

IX. User interface and communication

I. User interface

UPS operation shall be facilitated by a user interface, on each UPS unit, comprising:

- a graphic display;
- controls;
- status indications with mimic panel.

The information and controls shall be centralised by a system (electronic board) built into one of the UPS units.

II. Graphic display

The graphic display shall facilitate operation by offering the functions listed below.

- **Operating language:** It shall be possible to display in the language all the operating information supplied on the screens.

Step by step operating help

The graphic display shall assist the user by providing step by step help in the user's language.

- **Display of measurements**

It shall be possible to display the following measurements:

- inverter output phase-to-phase voltages;
- inverter output currents;
- inverter output frequency;
- voltage across battery terminals;
- battery charge or discharge current;
- rectifier/charger input phase-to-phase voltages;
- rectifier/charger input currents;
- active and apparent power;
- power factor of the load;

- **Display of status conditions and events**

It shall be possible to display the following indications:

- load on battery power;
- load on UPS;
- load on automatic bypass;
- general alarm;
- battery fault;

Remaining battery backup time;

- low battery warning;
- bypass AC source outside tolerances;

- **Display of operating graphs**

It shall be possible to display on the screen curves and bargraphs over significant periods for the measurements mentioned above.

- **Log of time-stamped events**

This function shall store in memory and make available, for automatic or manually initiated recall, time-stamped logs of all important status changes, faults and malfunctions, complete with an analysis and display of troubleshooting procedures. It shall be possible to time stamp and store at least 200 to 2000 events for each UPS unit.

III.Controls

The UPS shall comprise the following controls:

a. ON and OFF buttons

ON /OFF button shall control UPS-unit ON/OFF status.

It shall be possible to turn OFF the UPS externally via an isolated dry contact.

b. EPO terminal block

The UPS shall be equipped with an emergency power off terminal block for complete system shutdown following reception of an external control signal. The EPO command shall result in:

- a. shutdown of UPS units;
- b. opening of the static switch on the bypass line and of the battery circuit breaker;
- c. Opening of an isolated dry contact on the programmable card.

c. Alarm reset button

This button shall turn off audio alarms (buzzer). If a new alarm is detected after clearing the first, the buzzer sounds again.

d. Status indications with mimic panel

Indication of status conditions shall be distinct of the graphic display.

Three LEDs on the control panel indicate the following status conditions:

- i. load protected;
- ii. minor fault;
- iii. major fault.

The mimic panel shall represent the UPS and indicate the status of the load supply using five two-colour (red and green) LEDs:

- load supplied (LED at UPS output on mimic panel),
- inverter on (inverter LED on mimic panel),
- operation on battery power (LED between battery and inverter on mimic panel),
- bypass activated (bypass LED on mimic panel),
- PFC rectifier on (rectifier LED on mimic panel).

IV. Communication**i. Standard communication**

It shall be possible to remote the following controls, indications and measurements. To that end, each UPS unit shall have as standard equipment:

- d. a programmable card for input/ output information.

This card shall provide a total of eight dry contacts, six for outgoing information and two for incoming information.

- e. at least three communication ports for later addition, without interrupting operation, of communication cards implementing different protocols, e.g. SNMP, JBus/ModBus, RS232.

ii. Communications options

The UPS system shall be designed to enable the extension of communications, without system shutdown, to the following types of cards:

- a. an SNMP communication card for connection to an Ethernet network, for connection to a computer-network management system;
- b. an RS485 serial-link communication card capable of implementing the JBus/ModBus protocol for connection to a building management system (BMS);
- c. an RS232 serial-link communication card for communication with a modem and a remote-maintenance system;
- d. an XML-Web communication card for direct UPS connection to an intranet network, without connection to a server, capable of supplying information via a standard web browser.

The UPS shall be detectable by supervision software for large UPS systems.

Shutdown and administration software shall be available in addition to the communication cards.

V. Standards, tests and quality assurance

1. Standards

All equipment shall be designed and built in accordance with accepted engineering practice and applicable international standards, in particular the standards listed below.

- i. IEC 6014B-4: UPS - Performance.
- ii. IEC 62040-1 and EN 62040-1: UPS - Safety.
- iii. IEC 62040-2 level A: UPS - Electromagnetic compatibility [level C3 / C2 class A is optional].
- iv. IEC 62040-3 and EN 62040-3: UPS - Performance.
- v. IEC 60950 / EN 60950: Safety of IT equipment, including electrical business equipment.
- vi. IEC 61000-2-2: Compatibility levels for low-frequency conducted disturbances and signalling in public low-voltage power supply systems.
- vii. IEC 61000-3-4: Limits for harmonic current emissions (equipment input current > 16 A/ph).
- viii. IEC 61000-4: EMC - Electrical fast transient/burst immunity.

- ix. EN 55011 and EN 55022: Limits and methods of measurement of radio interference characteristics of industrial, scientific and medical (ISM) radio-frequency equipment - Level A conducted and radiated emissions.
- x. IEC 439: Low-voltage switchgear and controlgear assemblies.
- xi. IEC 60529: Degrees of protection provided by enclosures (IP Code).
- xii. ISO 3746: Sound power levels.
- xiii. CE marking/ Equivalent as per Indian standard.

The equipment must comply with environmental-protection standards; with production taking place on premises certified ISO 14001. The UPS design procedure shall be covered by an ISO 9001 quality system as well as a dependability study to ensure maximum reliability.

2. **Certification of conformity**

The manufacturer shall provide, on request, a complete qualification file demonstrating compliance with the above standards.

VI.Services

1. **Maintenance**

The DCO shall propose contracts covering four levels of maintenance.

- i. **Level one:** simple checks and settings, procedures accessible without any dismounting and involving no risk.
- ii. **Level two:** preventive maintenance, checks not inhibiting continuous operation of the system and preparing operators for Manufacturer services.
- iii. **Level three:** trouble-shooting. Repairs by standard exchange of subassemblies and functional power and control components. Preventive-maintenance operations, both systematic and when indicated by qualified diagnosis.
- iv. **Level four:** major preventive and corrective maintenance operations or technical upgrades during start-up, operation or renovation of the UPS installation and recycling of equipment or components representing a risk. These operations require the use of devices and means that have been calibrated by certified organisations.

2. **Technical competency**

- i. Customer operators: the supplier shall offer a level 2 training program.
- ii. Service personnel: the supplier shall ensure that service personnel are qualified for level 4.

3. System start-up

The system and equipment shall be started up on site by the supplier or its authorised agent. The procedure shall include checks on the characteristics of the upstream and downstream protection devices and on the UPS installation parameters.

4. Replacement parts

The supplier shall undertake to provide certified original replacement parts for at least ten years following the date of delivery.

5. Recycling and renovation/substitution

At the end of the UPS service life, the supplier shall guarantee the continuity of service of the customer's installations if necessary, including dismantling of equipment and replacement of equipment, in compliance with applicable standards on environmental protection.

VII.Warranty

The rectifier/ charger and inverter subassemblies shall be guaranteed (parts and labour on site) for five year following the start-up date.

The sealed lead-acid battery shall be covered by the same warranty as the UPS.

VIII.Services**Required services include:**

- supply of the UPS and any accessory parts or elements;
- carriage - paid UPS transportation and delivery to the site.

Options:

- UPS handling and installation on the site;
- connections between the battery and the UPS;
- connection of the normal AC source to the rectifier/ charger;
- connection of the bypass AC source to the input transformer or bypass input;
- connection of the load circuits to the UPS output.
- Static Transfer Switch: Static Switch (STS) should be planned for the IT equipments where there is no provision of redundant RPS, the equipments like L2 switches, Firewall, IPS etc may be considered. (The basic purpose of a static switch is that it takes the power from 2 sources and output it as one, it has an inbuilt automatic bypass switch which will enable any one source to be enabled and if one goes down the other input starts working which will give a uninterrupted power at the output. The specification is 16A STS switch.

1.3.1.4 Technical Specification – Diesel Generating Sets

Scope

Work covered by this contract shall conform to latest CPCB norms effective from July 1, 2004 include design, manufacture, supply, transportation, delivery, installation, testing and commissioning of automatic start direct coupled Diesel Generator Sets suitable for continuous round the clock operation at upto rated output with permissible overload along with associated works. Items included (but not limited to) in the contract are abstracted as below.

- Diesel engines directly coupled with alternators mounted on a rigid fabricated steel base frame with resilient antivibration mountings.
- AMF cum Auto Synchronising cum load sharing panels. All DG sets should be automatic, not manual. I.e. they should turn on and off automatically.
- DG cooling system. Radiator cooled.
- Exhaust piping with Silencer to provide 25 dBA insertion loss
- Electric starting equipment including batteries and battery chargers.
- Fuel supply system including Oil Storage and automatically operated Fuel Transmission System. Real Time Flow meter based monitoring of diesel through BMS should be there.
- Acoustic treatment of DG set as per prevailing norms.
- Statutory approvals including permission from Electric Supply Authority for operation of DG sets, approval from EB power authority clearance from Electrical Inspector, approval from Pollution Control Board.
- Coordination with DG Auto Synchronisation, Auto Load Control & AMF Panel Vendor. And there should be proper maintenance schedule to maintain the best efficiency.

PROPOSED OPERATIONAL SCHEME

The premises power supply is from Transformer for lighting, power and HVAC loads. The supply of transformer is not in the scope of bidder. The standby power also has 3 numbers of 320 KVA (+/-5%) DGsets for Entire loads which work in parallel fashion with auto synchronising facility.

The Synchronising power bus has been split into three different sections by two bus coupler. This has been done to ensure that, in case, the synchronising feature does not

work for any reason, the bus coupler can be switched off and the DG sets can be operated individually. All DG sets shall start immediately on sensing loss of EB power after an adjustable time gap from 0 to 10 seconds. This shall be controlled based on the time run by each of the DG sets and shall be field settable. Provision shall also be made to manually select the sequence of starting of the DG sets. Once all the DGs are in running condition, the Intelligent micro controller will switch off the DGs one by one based on the load condition. In case the load is less than 80% of 320 KVA (+/-5%), DG-3 will switch off first and then the DG-2. The DG-1 will be running and feed the load. At any point of time the load increases beyond 80% of 320 KVA (+/-5%) but within 80% of 640 KVA (+/-5%), DG-2 will start. The DG-3 will always act as a stand by to DG -1 and DG -2. In case of failure of DG-1 & DG-2, DG-3 will take over.

Upon restoration of Board Power, the changeover from DG power to Board Power will be automatically done by the AMF cum synchronising panel by switching off the DG set after a specified period of time. The AMF cum synchronising panel is given total manual override to take care of unexpected failure of auto start.

The Integrated microprocessor based controller on the DG set shall have auto synchronizing, auto load balancing and auto load management features.

GENERAL SPECIFICATION

The DG set shall be capable of safe, prime power continuous running at variable load for unlimited number of hours and shall also be able to run for one hour period in every 12 hours run period at 110% of the rated power. Noise, mechanical and thermal stresses shall be within permissible limits. The equipment shall be designed with regard to ease of maintenance, cleaning and inspection.

All parts subjected to substantial temperature changes shall be designed and supported to permit free expansion and contraction without resulting in leakage, harmful distortion. The DG sets and associated auxiliary equipments shall be manufactured as per relevant Indian standards and the lists of Indian standards are:

IS: 4722 - Specification for rotating machinery

BS: 649 - Performance and testing of diesel engines for general purposes.

IS 4729 - Measurement and evaluation of vibration of rotating electrical machines.

IEC 34 - Rotating electrical machines

BS 5000 - PART 3 Reciprocating IC engines: Performance

IS10002 - Performance requirements of Diesel Engines

BS 4999 (IEC 34-1) - Rotating electrical machines

IS 10000 (OR) Equivalent BS code - Method of tests for IC engines

BS 5514 / (ISP 3046) - ENGINE

The DG set shall comply with latest guidelines, regulations and Central Pollution Control board (CPCB) norms.

I. ENGINE

- The diesel engine shall be indoor-type, four stroke, multi-cylinder, 1500RPM with 2% speed variation for operation between 10% and 100% load, Turbo charged inner cooled, compression ignition with Electronic Fuel Injection system complete with its self contained lubricating system.
- Engine mounted radiator designed to dissipate the generated heat effectively shall be used.
- High-speed diesel oil shall be used as fuel for the engine.
- The engine shall be de-rated in accordance with the tables given in BS649 to suit site conditions.
- The engine shall be directly coupled to the generator.
- The noise level limitations shall be as per CPCB norms.
- The engine shall be capable of taking 10% overload for one hour in every 12 hours.
- The engine shall be capable of producing the desired nominal output at site referred to the generator terminals and with machine operating under ambient conditions as specified in the specific requirements.
- The lube oil system shall be provided with engine driven lube oil pump and lube oil-priming facility for use when the engine is not in operation
- The Engine to be fitted with silencer to provide min 25 dBA insertion loss.

ALTERNATOR WITH ACCESSORIES:

The Alternator shall have the following characteristics

Type - Brushless, rotating field design alternator rated for 660 volt / 50 Hz complying to IS 4722-1992, BS 5000 Part-III and IEC 34.

Excitation system - Permanent magnet generator (PMG) powered excitation system

Speed -1500 RPM

Net Site Output - Rated continuous at ambient conditions and as per schedule of quantities.

Voltage Regulation - Within 0.5% of the rated voltage

Overload - More than 10% of the nominal for 1 hour every 12 hours without exceeding permissible temperature rise.

Harmonics - Maximum 1% between phase and neutral and total maximum 3%

- The Alternator shall be capable of delivering the rated output at rated power factor as spelt out in specific requirement sheet
- The Alternator shall be capable of withstanding without damage a three-phase short circuit at its terminals when operating at rated KVA and PF and at 5% over voltage with fixed excitation for 3 seconds.
- The Alternator shall be capable of withstanding without damage
 - 50% overload for 15 seconds.
 - 10% overload for one hour every twelve hours.
- The line and neutral leads of phase windings of the Alternators shall be in suitable terminal boxes with flexible rubber bellows wherever the outgoing is Busduct.
- The neutral shall be taken to a neutral earthing cubicle cum DG control panel, where 1 No of CT shall be provided in the neutral before connecting it to ground point. The CT shall be connected to an E/F relay for generator protection. The neutral shall be taken to the ground through a removable link. The relays and motors shall also be housed in the control panel. Please refer to enclosed specific requirement sheets.
- Thermistors shall be provided in the Alternators windings and connected to Thermistors relay at the cubicle, which shall have contacts for alarm and trip.
- The neutral earthing cubicle/control panel shall all be integrated into one vertical hosing all the switches, lamps, annunciators, relays, etc.
- The Alternator winding shall have class of insulation H class with temperature rise limited to Class B.

AUTO-SYNCHRONISING CUM AMF CUM AUTO LOAD MANAGEMENT PANEL

The control and power panel shall comprise of components as specified in the BOQ including meters, protection relays, switchgears, control components, control and power wiring etc.

The panel manufacturer must have a CPRI or ERDA certification for a panel of equivalent rating or more.

The panels shall be fabricated from 2mm thick CRCA sheet and load bearing members with 2.5 mm thick. This shall be of compartmentalized and sectionalized design. The main supporting framework shall be of angle iron or of heavier gauge sheet metal. The panel shall be self-supporting design, dust and vermin proof, dead front and fully inter locked with isolating switches. The panel should meet IP54 or better requirements.

The panel shall be designed so as to facilitate inspection, cleaning and repairs. The clearance between phase to phase and phase to earth or metal parts shall be as per relevant IS standards. The metering instruments like voltmeter, ammeter etc. shall be (as per B.O.Q) flush mounted and shall be of 0.5 class accuracy and of standard design. All indication lamps shall be of LED lamp type.

The panel shall be treated for rust protection comprising of de-greasing and de-scaling in Sulphuric acid, baked and powder coated for smooth finish. The colour of paint shall be Siemens grey. The Panel shall be tested at site before commissioning. The Panel drawings shall be first got approved from consultants before taking up for fabrication.

The panel shall have separate cable alley and a bus bar chamber. The bus bars shall be rigid hard drawn Aluminium and insulated with colour coded heat shrinkable sleeves. The neutral bus shall be rated for capacity of half the size of phase bus unless otherwise stated in schedule of quantities/ drawings.

All busbars, cables, wires, lugs etc. adequately rated and temperature de-rated.

All control cabling/ wiring inside the panel shall be done with FRLS copper conductor wires/ cables rated for 1100 V and of adequate current carrying capacity but in any case the current drawn by the conductor shall not exceed 80% of the total current carrying capacity of the cable/ wire. The cables/ wires shall be a minimum of 2.5 sq. mm cross-section.

All the control / power cabling and bus bars must be colour coded as follows only:

- Red for red phase

- Yellow for yellow phase
- Blue for blue phase
- Black for neutral
- Green for earthing.

The insulation of the cable / wires shall be PVC FRLS. The minimum size of cable / wires shall be: < 25 Amps - 6.0 sq. mm, >25 Amps < 32 Amps - 10 Sq.MM, > 32 Amps < 45 Amps - 16 sq. mm, >45 Amps < 55 Amps - 25 sq. mm, > 55 Amps < 72 Amps - 35 Sq.MM, > 72 Amps < 95 Amps - 50 sq. mm, > 95 Amps < 125 Amps - 70 sq. mm, > 125 < 160 Amps - 95 sq. mm, > 160 Amps < 180 Amps - 120 sq. mm. For higher current ratings bus bars shall be preferably used. The specifications stated under Cabling and termination of this specification shall apply.

The insulators for supporting the Bus-Bars shall be SMC / DMC type. All the power components/ frames installed in the panel shall be earthed from the main bus with adequate size of bus bar. The doors shall be fitted with concealed hinges and shall be earthed with flexible braided copper earth, to be connected to the earth bus. An earth bus of copper 100 mm x 5 mm shall be fixed along the length of the panel at the lower section. Adequate ventilation for the panel shall be provided. Logic diagram of operation of switches shall be with LED mimic. The nameplates for each feeder shall be of engraved design and screwed to the respective switchgear. The letters shall not be less than 10 mm size for individual feeders and not less than 15 mm for the main feeders. All switchgear to be mounted in the panel shall be as per schedule of quantities.

The minimum depth of the panel shall be 1 meter. All connections shall be accessible from the back. For ease of cable terminations the outgoing links of all feeders shall be extended by 0.5 meter at the back duly supported on insulators.

The panel may be connected to a Building management system and the contractor shall take into account the requirements and shall provide potential free contacts brought out to the gateway terminal blocks rated minimum 10 A at 230 V. All CT secondary connections shall be routed through linked terminal block.

A separate dedicated cubicle / compartment shall be provided with terminal blocks for connections to and from the BMS to the feeders for remote monitoring.

Type: Cubical, front operated with detachable cable gland plates 2mm thick for top/ bottom cable entry.

Enclosure: 2MM CRCA suitably rust inhibited and baked enamel painted and provided with square section neoprene gaskets. Load bearing members shall have a thickness of 2.5 mm with IP54 protection.

Mounting: Floor mounted with channel framework of 100mm height.

The panel shall have space heaters, ventilation fans, earthing, sheet steel treatment as Described in the LV Switchgear panel.

For all equipment's (components) installed in the panel, certificates issued by the manufacturer shall be provided.

AMF FEATURE

- While the GRID supply is healthy, the Diesel Generating set is at rest and load is supplied directly by the grid through grid circuit breaker.
- The 415V 3Ph, 4wire supply, tapped from line the side of incomer, will be fed as input to the AMF panel. The status of the supply has to be monitored by the U/V relay provided in the AMF panel.
- When the Grid voltage fails or drops below a certain pre-set value, the automatic control system gives a starting signal to the diesel generator set after ensuring the grid CB at 415v MAIN PANEL (PMCC) is off.
- As soon as the alternator set reaches its operating speed & rated voltage, then a signal shall be generated by the D.G control panel to close the DG incomer CB at 415V MAIN PANEL (PCC).
- A maximum of three attempts of starting facility for the DG set shall be provided and in case the diesel engine fails to start & reach its operating speed with in stipulated time, as per DG set characteristic, the feature should automatically lock out the operation of DG set and further operation of DG set should be prevented in both auto & manual condition. This lockout signal shall be given to a hooter, indication lamp with rest button and two potential free contacts.
- When the main supply restored to normal value for atleast one minutes then a suitable signal shall be generated and close the Main supply breaker automatically and open the DG supply Breaker.
- The set has thus reverted to its standby condition and will only start when the mains fail again.
- After restoring back to its normal operation (i.e the grid feeding the loads while DG is off), if the grid supply fails once again with in ONE hour of restoration, then the

grid breaker (415v) shall be tripped off and the AMF circuit shall be triggered by the DG control panel. Then the system should remain in D.G operation and the feature of automatic switching over from DG to GRID shall be locked-out. This feature shall be put in to function only after operating personnel's intervention. This shall be suitably annunciated in the control panel.

- Selector switch shall be provided to select the following feature.
 - Auto/ Manual

The DG Synchronising panel will have all necessary relays, devices etc. for operating the DG in Auto Synchronising mode with necessary facility for sharing the loads automatically in each DG and performing the synchronising through relays. This shall also have facility such that in case Auto Synchronising fails, manual synchronising can be done.

The sensing to start the DG under EB source failure shall be with Auto Mains failure feature. The load sharing shall be done with load controllers, which should be settable for each DG independently and give the command to start the DG after one DG reaches particular set load.

The microprocessor should be a complete integrated, automatically synchronising load controller with protection relays and engine and alternator management features having the following essentials:

i. Engine control

Engine pre-glow, Fuel solenoid control, engine starter control, KVA controlled cool down timer, Oil pressure monitoring, water temperature monitoring, battery voltage monitoring, speed monitoring and over speed protection.

ii. Synchronizing

Digital signal processing to eliminate harmonic contents induced in system, adjustable phase voltage windows, windows as small as 2 deg. phase errors and 1% voltage matching, safe dead bus closing, multiple re closing with adjustable time delay, auto and check synchronizing relay, manual voltage and speed adjustments for manual synchronizing (synchro check must be active during manual synchronizing).

iii. Load controller

True RMS power for load control, iso synchronous auto load sharing of KVAR & KW equally with a tolerance of 5%, KW and KVAR droop for manual load control, VAR sharing, VAR & PF control.

iv. Automatic generator sequencing

Auto starts generator when load exceeds a preset % load, controlled unloads for engines, engine priority sequence. The Sequencing of DG sets shall be done using selector switch, timer, Micro processor based relay and necessary control circuiting such that normally the DG, which has been given the priority, shall start. When the load exceeds preset % of the DG capacity the other DG shall start and the load shall be shared equally.

v. Generator protective features

Over & under voltage, Over & under frequency, Reverse power, loss of excitation, loss of main detection, speed / frequency mismatch, load surge, KVA load switch, inverse and definite time over current and earth fault, restricted earth fault, differential protection.

vi. Engine protective features

High / Low coolant temp, High / Low oil pressure, Over speed, Start failure, Over crank.

vii. PC interface

Easy upload and download of configuration set points

Communication with third party devices / BMS through RS 232 C and Backnet protocol.

TESTING OF THE PANEL

Skeleton testing: On approval of the drawing the contractor shall inform at least three days in advance for inspection of the skeleton fabricated and painted and ready for mounting the switch gear.

The panel shall be assembled in factory and tested for the following:

- Insulation resistance
- HV test.
- Operational test with all functional inter locks.
- CT secondary injections for protection and metering circuits. The contractor shall keep all the test equipments ready at site.

viii. DRAWING SUBMISSION:

The following shall be submitted for approval for DG set:

Drawing Name	Number of copies
a. Foundation drawing with loading data :	--- 05 ---
b. Schematic drawings :	--- DO ---
c. All control & Indication circuit drawings :	--- DO ---
d. Schematic P&I drawing for Lube oil :	--- DO ---
e. Component list with ratings & ranges: of all items.	--- DO ---
f. Design/Engineering of DG exhaust system including BOQ :	--- DO ---
g. Design/Engineering of DG cooling system Radiator type cooling with BOQ :	--- DO ---
h. Design / Engineering of automatic Fuelling system including the BOQ. :	--- DO ---

The final drawings with erection/operation & maintenance manual and literature, write ups and description of DG set excitation system, voltage regulator governor and other auxiliaries shall be submitted.

ix. TOOLS

Tenderer shall submit a list of the tools to be used for installation and operation.

x. PRE-COMMISSIONING CHECKS

All standards checks including the ones elaborated in the specifications to ensure that the installation of the DG sets and associated systems has been carried out satisfactorily shall be done on completion of installation. These shall include.

DG sets

- Checking of piping interconnections
- Checking electrical interconnections

- Checking of insulation resistance
- Checking of earthing
- Checking of instruments and controls.
- Checking of alignment
- Checking of vibration transmission to building a structure.
- Checking of expansion joints.

Fuel system

- Checking of automatic operation of fuel transfer pumps. If separate bulk storage tank is provided.

Exhaust system

- Checking of Surface Temperature of Exhaust Piping.
- Checking of Silencer operation.

xi. PERFORMANCE TESTING AND TYPE TESTS

i. Performance Testing

DG sets shall be tested at varying loads at manufacturers works prior to dispatch of the sets to site. The performance tests at the works shall be carried out in presence of authorized representative from the Engineer-in-Charge. Due notice for the programme of performance testing at works shall be given to the Engineer-in-Charge to enable them to arrange for their representatives for this inspection to be at manufacturers works for this inspection and testing. The costs for the arrangement shall be borne by the Contractor.

The performance test on each DG sets shall be of minimum 8 hours duration.

All instruments, materials, consumables (fuel oil, lube oil etc.) load and labour required for carrying out of the test shall be provided by the Contractor.

Following test acceptance criteria shall be applicable.

Fuel consumption at 50%, 75%, and 100% load.	+ 5% of guaranteed performance. Actual alternator efficiencies as determined in the manufacturer's works tests shall be used as the basis of calculation of specific fuel consumption ratio.
--	--

Voltage regulation from no load to full load	+ 0.5%
Frequency regulation from no load to full load	+ 0.5%
Maximum water temperature	+ 5% of guaranteed performance
Maximum lubeoil temperature	+ 5% of guaranteed performance
Minimum lubeoil pressure	+ 5% of guaranteed performance

ii. Test Certificates

Copies of all documents of routine and type test certificates of the equipments shall be furnished to the department along with the supply of equipments and these are as below.

Routine Test Certificates.

- Engine separately
- Alternator Separately

Type Test Certificates

- Engine
- Alternator
- All major components

iii. PERFORMANCE GUARANTEE:

The performance figures quoted in the technical particular sheets shall be guaranteed within the tolerance permitted by relevant; standards. In case of failure of equipment to meet the guaranteed figures, the purchaser reserves the right to reject the equipment. The rejected equipment may be used by the purchaser till the new equipment meeting the guaranteed requirements is supplied by the vendor.

- Daily Service fuel Tank/ Buffer Tank

Day fuel tanks / Buffer tank 990 litres capacity shall be provided. The tank shall be fabricated from not less than 3 mm M.S. Sheet. A removable cover of ample size with lock shall be provided to permit access to the tank interior. The tank shall be provided with all required appurtenances like inlet and outlet connections, drain connection, overflow connection etc. Fuel level indicator with low and high level visual shall be provided. The day tanks shall be floor/ wall supported on steel support 300 mm above FFL. Outlet valves

from all storage tanks shall be located at easily accessible points so as to facilitate immediate shutting off of the fuel supply in case of emergency. Each tank shall also be provided with measuring scale to check the level of oil manually.

- Pipes and pipe fittings

The MS pipes shall be of minimum class C (Heavy gauge) type. Makes of pipes and pipe fittings shall be as stipulated in the list of approved makes and as approved by Project Managers.

TESTING

Hydrostatic test to be carried out at manufacturer's works.

- Examination of welds shall be done by visual means. However, non-destructive testing such as spot radiography shall be carried out at manufacturer's works.
- All gauges and templates necessary for inspection, to the satisfaction of the inspector shall be supplied by the manufacturer.
- All tanks shall be subjected to hydraulic test at a pressure of 0.05 Mpa and checked for leaks. Test shall be carried out at manufacturer's works.

The Tenderer/Vendor shall obtain Explosive Certification & Other Statutory Approvals if applicable.

SPECIFIC REQUIREMENT SHEET

General

Quantity	:Refer Latest BOQ.
Type	:Radiator cooled
Rated voltage	:415V 3 Phase
Frequency	:50 Hz
Rated output of alternator	:Refer Latest BOQ
Rated power factor	:0.8 lagging
Degree of protection	:IP-23.Type of enclosure Screen Protected Drip Proof
Ambient temperature	:50 deg C
DG Auto mains failure cum	
Synchronising cum load sharing	

Control panel :included in scope of Panel vendor but corelation should be made with DG amanufacturer

- a. List of annunciations required on the DG Auto mains failure cum Synchronising cum load sharing control panel
 - Safety control trip for low lube oil pressure.
 - Safety control trip for high water temperature.
 - Safety trip for over speed.
 - DG fails to start.
- b. List of meters/reading required on the control panel on engine:
 - Lube oil temperature gauge.
 - Lube oil pressure gauge.
 - Water temperature Gauge.
 - Hour meter and RPM indicator.

Protection system:

THERMISTORS : As per spec. for winding

CT-Neutral Side : 1 no. (One on each lead)

Protection Core Ratio

Burden : 10VA

Class of accuracy : 5P10

Relays : THERMISTOR Relay

: On neutral side 51N element, range setting 10% to 40%, relay shall be provided

Indication lamps : Red, Yellow, Blue indication lamps for

Voltage indication.

- a. "Load on" indication Lamp.
- b. "Engine ON" indication lamp.
- c. "Grid supply healthy" indication lamp.

Switches / PB's :

- a. Starting Switch with key

- b. Auto/Manual sel. switches for "AVR " .
- c. Raise/Lower PBs for speed & voltage.
- d. Emergency stop PB (for Tripping DG breaker at PCC panel).

Annunciator: 12 window solid state annunciator with Test / Accept / Reset PBs.

BMS requirement: There will be integration of the DG system status, fuel tank level, fuel pump Operation, Panel with the BMS system, Necessary provisions to be made in respective areas.

The bidder has to ensure that there is an automatic system installed which allows for measurement of the diesel consumed and this system should also be integrated with Building Management System (BMS). The Flowmeter concept that has to be used for this is as mentioned below:

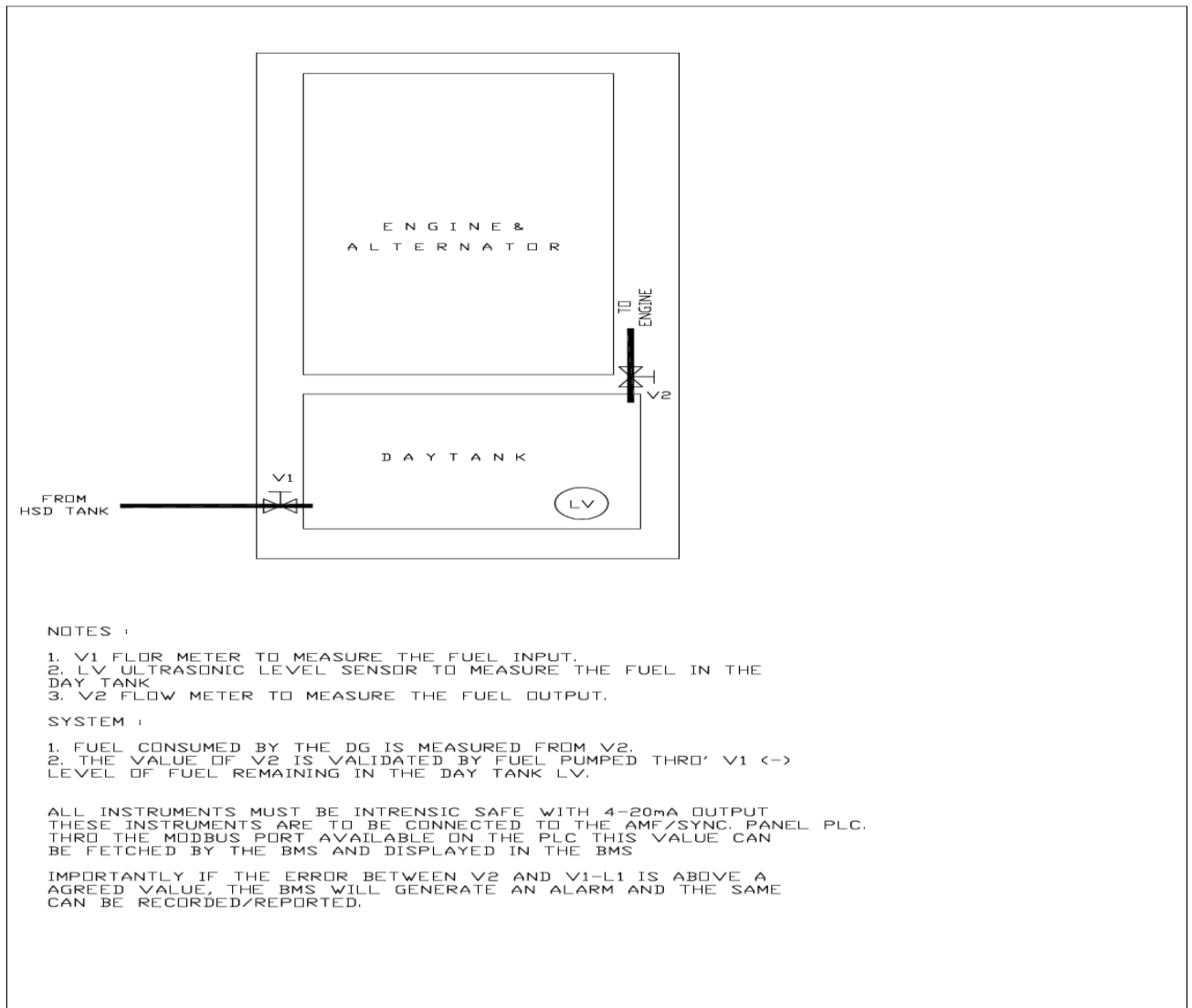

EXHAUST SYSTEM FOR DIESEL GENERATING SETS

I. SCOPE

The scope of this section is to design, supply, erection, testing and commissioning of D.G exhaust system in accordance with the prevailing Indian standards and Central Pollution Control Board norms.

The vendor shall study the location of DG set placement & shall provide the exhaust piping as per the norms & prevailing condition.

The scope should cover design of system, all necessary calculations, piping, piping supports, foundations and necessary steel cladding as required.

The vendor should submit all necessary drawings and calculations for approval.

Provision of testing port shall be provided on exhaust pipe line.

II. TESTING

Vendor shall carry out the tests as per codal requirements and CPCB requirement. The following testing is to be done.

- Checking of silencer operation
- Checking of surface temperature of exhaust piping

III. MISCELLANEOUS

All allied and implied equipments and accessories required for complete operation of the system shall be supplied and installed by the vendor, whether specifically mentioned or not.

The bidder/ supplier shall be responsible for engineering and functioning of complete system, fully meeting the intent and requirements of the specifications, attached data sheets/ drawings.

Necessary acoustic doors, acoustic Louvered doors, Ventilation hood for taking hot air from radiator, all other implied and allied items required for completely making the room sound proof as per CPCB norms.

Optional to provide factorymade acoustic enclosure with the prevailing norms.

Applicable Standards

The acoustic treatment system / sound proof system shall be in accordance with the standards given below and any other Indian Standards prevailing at the time of execution.

- IS 1950 (1962) – Code of Practice for Sound insulation of Non-Industrial Buildings.

- Central Pollution control Board norms with Latest amendments.

Noise and Vibration Control in Diesel Generator Room

The scope of this section consists of noise control measures for the DG set rooms and ventilation system include sound absorbing treatment to DG room, provision of sound reducing doors, provision of silencers in the ventilation system and provision of primary and secondary exhaust mufflers in the engine exhaust piping.

ACOUSTIC TREATMENT

Maximum permissible sound pressure level for the DG sets shall be 60 dBA at 1 m from the DG room with doors closed. The acoustic treatment shall achieve minimum 25 dBA insertion loss or meeting the ambient noise standards whichever is higher. If the ambient noise is higher, the performance of acoustic treatment shall be checked for noise reduction upto actual ambient noise level, preferably at night times. The measurement of insertion loss shall be done at different points at 0.5 m from the DG room and then averaged.

Walls and ceiling of DG room shall be acoustically treated by means of minimum 75 mm thick mineral wool of 64 kg/m³ density to achieve an insertion loss of minimum 25 dBA and a sound level of max. 60 dBA at 1 m from DG room.

In case the desired reduction in sound level to achieve max 60 dBA outside DG room at 1 m distance (with doors closed) is not achieved with the above treatment, the bidder shall provide additional thickness of acoustic insulation of the same or modified density to achieve the required reduction in sound level without any extra cost.

DG bidder shall also coordinate with DG room ventilation bidder regarding acoustic treatment (if applicable) of fresh air inlets and exhaust outlets to achieve the desired reduction in sound level outside the DG room.

PERFORMANCE

The specification indicates the general layout and measures required for meeting the end noise and vibration requirements. The bidder shall include in his offer whatever other materials are required to be supplied for satisfactory installation and performance of the system so as to meet the end criteria.

Design Requirements

- i. Noise Levels: Noise Level to be achieved outside the D.G room as per CPCB norms.
- ii. Layout

Room Size: As per site condition.

iii. Testing

Vendor shall carry out the tests as per codal requirements and CPCB requirement.

iv. Miscellaneous

All allied and implied equipments and accessories required for complete operation of the system shall be supplied and installed by the vendor, whether specifically mentioned or not.

CPCB Certificate shall be attained by the vendor after successful completion of the complete DG installation including the acoustic works.

1.3.1.5 Technical Specifications – Electrical: Low Side

I. GENERAL SPECIFICATIONS

i. SCOPE:

In general, the prime vendor/DCO shall supply, store, erect, test and commission all the equipment required for Electrical Installation. The DCO shall furnish all the materials, labour, tools and equipment for the electrical work, and in the bill of quantities and specifications herein after described.

ii. Prime Vendor/ DCO:

The DCO shall be Class A - licensed electrical contractor, possessing a valid electrical contractor license in the state, employing supervisors and skilled workers having a valid permits as per the Regulation of Indian Electricity Rules and Local Electrical Inspector's requirements and the same shall be got renewed from time to time.

iii. INFORMATION TO BIDDERS:

- a. The design and quality of goods supplied and the workmanship shall be in accordance with the best engineering practice to ensure satisfactory performance of the system throughout the service life.
- b. The goods and accessories offered shall be complete in all respects. Any material, and/ or component not specifically stated in this specification which is necessary for trouble free and successful operation shall be deemed to be included unless specifically excluded. All such components, accessories, etc., shall be supplied at no extra cost.
- c. The goods supplied shall be such that components, accessories of the same type shall be interchangeable. Likewise similar or corresponding parts, components/ accessories shall also be interchangeable.
- d. Wherever and whenever a material or article is specified or described by the name of a particular brand, manufacturer, vendor, the specific item mentioned shall be understood as establishing type, function, quality and not as limiting brand. However bidders may offer other similar components/ accessories provided they meet with the required standards, design, duties and performance. The bidders are free to use any brand as specified in the list of approved makes and no deviation shall be accepted by End user.

- e. Goods and accessories so offered shall conform to type tests and shall also be subjected to acceptance and routine tests in accordance with the requirements stipulated in this specification.

iv. STANDARDS:

Except as modified by this specification all materials to be supplied shall conform to the requirements of the latest editions of relevant standards mentioned there in.

v. DEVIATION IN SPECIFICATION:

All deviations in specification shall be brought out by the bidder and detailed clause by clause.

1. Deviation brought out elsewhere or in any other format will not be considered by the client and are liable for rejection. It shall also be deemed by the client in such an event that the bidder has conformed to the clauses in this specification scrupulously.
2. Deviation in specifications shall if possible be quoted with reference to standards. The bidder shall then furnish an authentic English version of such standards.

vi. LOCAL CONDITIONS:

1. It will be imperative on each bidder to fully inform himself of the local conditions and factors which may have any effect on the execution of the supply and services covered under these documents and specification.
2. It shall be understood and agreed that such factors will have been properly investigated and considered in any bid that is submitted. No claim for financial adjustments to the contract awarded under these specifications and documents will be entertained by the purchaser neither change in the time schedule of the contract nor any financial adjustments arising thereof shall be permitted by the client, which are based on incorrect information or its effect on the cost of the contract to the bidder.
3. Bidder are advised to visit the various areas where the U.G. Cables/ Earth pits are going to be installed and assess the problems due to restrictions in access, crossings to enable them to make proper costing and then quote accordingly.

II. TECHNICAL SPECIFICATION FOR LT PANELS

i. THE POWER CONTROL PANELS

The power control panels shall be metal clad, totally enclosed, rigid, floor mounting, air insulated, cubical type for use on 415 volts, 3 phase, 4 Wire 50 cycles system. The

equipment shall be designed for operation in high ambient temperature and high humidity tropical atmospheric conditions. Means shall be provided to facilitate ease of inspection, cleaning and repairs, for use in installations where continuity of operation is of prime importance.

- ii. The equipment shall be designed to conform to the requirements of:
 - a. IS 4237 - General requirements for switchgear and control gears for voltages not exceeding 1100 volts.
 - b. IS 2147 - Degree of protection provided by enclosures for low voltages switchgear and control gear.
 - c. ARE 375 - Marking and arrangements of bus bars.

Individual equipment housed in the power control to the following IS specifications:

- i. Air circuit breakers - IS 2516 (Part I & II/Sec.1) 1977
- ii. Fuse switch and switch fuse units - IS 4064 : 1978.
- iii. Fuse links - IS 1108 : 1962 or IS 9114 : 1979.
- iv. Current Transformer - IS 2705.
- v. Voltage Transformer - IS 3156.
- vi. Relays - IS 3231.
- vii. indicating Instruments - IS 1248.
- viii. Integrating Instruments - IS 711.
- ix. Control Switches and push buttons - IS 6875.
- x. Auxiliary DCOs - IS 2959.

iii. CONSTRUCTIONS:

The power control panels shall be:

- i. Of the metal enclosed, indoor, floor mounted free standing type.
- ii. It shall be made up of therequisite vertical section, which when coupled together shall form continuous dead front switch boards.
- iii. Provide dust and dump protection, the degree of protection being not less than IP 52 to IS - 13947.

- iv. Be readily extensible on both sides by the addition of vertical sections after removal of the end covers.

Each vertical section shall comprise:

- i. A front framed structure rolled / folded sheet steel channel section of minimum 3mm thick, rigidly bolted together. This structure shall house the components contributing to the major part of the equipment, such as circuit breaker cassettes, fuse switch units, main horizontal bus bars, vertical risers and other front mounted accessories.
- ii. The structure shall be mounted on a rigid base frame of folded sheet steel of minimum 3mm thick and 100mm height. The design shall ensure that the weight of the components is adequately supported without deformation or loss of alignment during transit or during operation.
- iii. A cable chamber shall house the cable end connections of power / control cable termination. The design shall be to ensure generous availability of space for easy installation and maintenance of cabling, and adequate safety for making in one vertical section without coming into accidental contact with live parts in and adjacent sections.
- iv. A cover plate at the top of the vertical section, provided with a ventilating hood where necessary. Any aperture for ventilation shall be covered with a perforated sheet having less than 1mm diameter perforated to prevent entry of vermin.
- v. Front and rear doors shall be fitted with nuts/ bolts including neoprene gaskets with fasteners designed to ensure proper compression of the gaskets. When covers are provided in place of doors, generous overlap shall be assured between sheet surfaces with closely spaced fasteners to preclude the entry of dust. The height of the panel should not be more than 2400mm. The maximum height of any operating mechanism shall not be more than 2100mm. The total depth should be adequate to cater for proper cabling space.
- vi. Doors and covers shall be of minimum 14 gauge sheet steel. All sheet steel work forming the exteriors or switchboards shall be smoothly finished, leveled and free from flaws. The corners should be rounded.

The apparatus and circuits in the power control panels shall be so arranged as to facilitate their operation and maintenance and at the same time to ensure the necessary degree of safety.

Apparatus forming part of the power control panels shall have the following minimum clearances:

- i. Between phases - 25 mm

- ii. Between phases and neutral -25 mm
- iii. Between phases and earth -25 mm
- iv. Between neutral and earth - 25 mm

If for any reason, the above clearances are not available suitable insulation shall be provided. Clearance shall be maintained during normal services conditions.

Creepage distances shall comply with those specified in relevant standards. All insulating materials used in the construction of the equipment shall be arranged in multi-tier formation, except that not more than two air circuit breakers shall be housed in a single vertical section. Metallic / insulated barriers shall be provided within vertical sections and between adjacent sections to ensure prevention of accidental contact with:

- i. Main bus bars and vertical risers during operation, inspection or maintenance of functional units and front mounted accessories.
- ii. Cable termination of one functional units, where working of those of adjacent unit / units.
- iii. All covers providing access to live power equipments / circuits shall be provided with tool operated fasteners to prevent unauthorized access. Provision shall be made for permanently earthing the frames and other metal parts of the switch gear by two independent connections.

iv. METAL TREATMENT AND FINISH:

All steel work used in the construction of the switchboards should have undergone a rigorous metal treatment process as follows:

- a. Effective cleaning by hot alkaline degreasing solution followed by cold water rinsing to remove traces of alkaline solution.
- b. Picking in dilute sulphuric acids to remove oxide scales and rust formation, if any, followed by cold water rinsing to remove traces of acidic solution.
- c. A recognized phosphating process to facilitate durable coating of the paint on the metal surfaces and also to prevent the spread of rusting in the event of paint film being mechanically damaged. This again, shall be followed by hot water rinsing to remove traces of phosphate solution.
- d. Passivating in de-oxalite solution to retain and augment the effects of phosphating.
- e. Drying with compressed air in a dust free atmosphere.
- f. Primer coating, with two coats of highly corrosion resistant primer, applied wet on stove dried under strictly controlled conditions of temperature and time.

g. A finishing coats (two coats) of power costed to the specified shade of IS.

The total thickness of paint should not be less than 25 microns.

v. BUS BARS

1. The bus bars shall be air insulated and made of high conductivity, high strength aluminium / electrolytic grade copper complying with the requirement of grade E91E of IS 5082.

2. High tensile bolts and spring washers shall be provided at all bus bar joints.

3. The main phase bus bars shall have continuous current rating throughout the length of each power control panel, and the neutral busbars shall have a continuous rating of at least 100% of the phase bus bars.

4. Bus bars shall be colour coded for easy identification of individual phases and neutral and protective earth.

5. CURRENT TRANSFORMER: Current transformer shall comply with the requirements of IS 2705. They shall have ratios, outputs and accuracy's as specified / required

6. INDICATING / INTERGRATING METERS: All indicating instruments shall be of flush mounting industrial pattern, conforming to the requirements of IS 1248. The instrument shall have non-reflecting dial, clearly divided and legibly marked scales and shall be provided with adjusting devices in the front

7. CABLE TERMINATION: Cable entries and terminals shall be provided in the switch-board to suit the number, type and size of aluminium conductor, power cable and copper conductor control cable specified in the detailed specifications.

8. Provision shall be made for top or bottom entry of cables as required. Generous size of cabling chambers shall be provided, with the position of cable glands and terminals such that cables can be easily and safely terminated. The minimum depth of the panel shall be restricted to 1600 mm for this purpose.

9. Barriers or shrouds shall be provided to permit safe working at the terminals of one circuit currents without accidentally touching that of another live circuit. Cabling risers shall be adequately supported to withstand the effects of rates short circuit currents without damage and without causing secondary faults. Cable sockets shall be of copper and of the crimping type as specified.

10. TVSS wherever required must be used in the panels to restrict the surge.

vi. CONTROL WIRING:

1. All control wiring shall be carried out with 1100 V grade single core PVC cable conforming to IS 694 / IS 8130 having standard copper conductor of minimum 2.5 Sqmm section for potential circuits and 2.5 mm section for current transformer circuits. Wiring shall bear neatly bunched, adequately supported and properly routed to allow for easy access and maintenance.

2. Wire shall be identified by numbered ferrules at each end. The ferrules shall be of the ring and of non-detoriating materials. They shall be firmly located on each wire so as to prevent free movement. All control circuit fuses shall be mounted in front of the panel and shall be easily accessible.

vii. TERMINAL BLOCKS:

Terminal blocks shall be of 500 volts grade of finger touch proof type. Insulating barriers shall be provided between adjacent terminals.

viii. LABELS:

Labels shall be on anodized aluminum, with white engraving on black background. They shall be properly secured with fasteners.

ix. TESTS:

Routine tests shall be conducted on each power control panel in accordance with CI 81, 2.2 of IS 8623 and shall comprise:

- i. Inspections of the power and control circuits including inspection of wiring and electrical operational tests where necessary.
- ii. Dielectric tests.
- iii. Checking of protective measures and electrical continuity of the protective circuits.

x. STORING:

The panels shall be stored in well ventilated dry places. Suitable polythene covers shall be provided for necessary protection against moisture.

xi. ERECTION:

Switch boards shall be installed on suitable foundation. Foundation shall be per the dimensions supplied by the panel manufacturer. The foundation shall be flat and level. Suitable grouting holes shall be provided in the foundation. Suitable MS base channel shall be embedded in foundation on which the panel can be directly installed. The switch boards shall be properly aligned and bolted to the foundation by bottom plate or top plate as the case may be, by using brass Siemens type compression glands. The individual cables shall then be led through the panel to the required feeder compartments for

necessary terminations. The cables shall be clamped to the supporting arrangements. The switch board earth bus shall be connected to the local earth grid.

xii. PRE-COMMISSION TESTS:

Panels shall be commissioned only after the successful completion of the following tests.

The tests shall be carried in the presence of SIA's representative.

- a) All main and auxiliary bus bar connections shall be checked and tightened.
- b) All wiring terminations and bus bars joints shall be checked and tightened.
- c) Wiring shall be checked to ensure that it is according to the drawings.
- d) All wiring shall be tested for insulation resistance by a 1000 Volts Megger.
- e) Phase rotation tests shall be conducted.
- f) Suitable injection tests shall be applied to all the measuring instruments to establish the correctness and accuracy of calibration and working order.
- g) Suitable injection tests shall be applied to all the measuring instruments to establish the correctness and accuracy of calibration and working order.
- h) All relay and protective devices shall be tested for correctness of settings and operation by introducing a current generator and ammeter in the circuit.
- i) High voltage test with 2.5KV for 1 min on power as well as control circuits.

xiii. CIRCUIT BREAKERS:

I. Air Circuit Breakers:

General:

1. Air circuit breakers shall conform to IS 13947-1 /IEC947-1 for general rules and IS13947 - 2 /IEC947-2 for circuit breakers.
2. ACBs shall be suitable for operation on 3 phase 660 Volts, 50Hz AC supply and shall have a rated insulation voltage of 1100V AC.
3. All circuit breakers shall be fully tropicalized - (T2) standard and pollution degree IV.

Type & Construction:

1. The Breaker shall be suitable for rear horizontal & vertical mounting and line load reversibility, without any deration.

2. The breaker shall comply with isolating function requirement of IS 13947-2/IEC 947 - 2 sec 7.1.2.
3. The breaker shall offer total insulation of the control part with respect to the power part and preferably shall offer double insulation on the front face (Class II degree of operating safety).
4. Inspection of the main contacts should be facilitated by a mechanical wear indicator.

Operating Mechanism:

1. ACBs shall be provided with motor operated or manually operated quick make, quick break, trip-free operating mechanism.
2. Wherever specified, motorised spring charging mechanism suitable for AC or DC shall be supplied.

Interlocking & safety arrangement:

1. The microprocessor control unit shall be equipped with a push to reset mechanical indicator, for anti-pumping function.
2. It shall not be possible for breaker to be switched 'ON' until it is either in 'Service' or 'Test' position.
3. The breaker shall be capable of being racked into test or isolated position and kept locked in any of these positions.
4. It shall not be possible to withdraw the breaker when the springs are charged.
5. It shall not be possible to insert breaker racking handle when cubicle door is open. It shall have defeat interlock facility.
6. Safety shutters should be closed automatically when ACB is withdrawn
7. OFF position pad-locking arrangement is required.

Rating & Breaking Capacity

1. The rating of the circuit breaker shall be as per the schedule of quantities. The ACB shall have minimum Service Breaking Capacity (Ics) equal to Ultimate Breaking Capacity (Icu)

2. The minimum Service breaking capacity (Ics) for rating upto 1600A shall be 65kA and for rating above 1600A, the service breaking capacity shall be 75kA.

The Short time withstand(Icw) for 1 sec for rating upto 1600A shall be 50kA and for rating beyond 1600A Short time withstand (Icw) shall be 75kA

Protection:

1. The microprocessor release shall be housed in separate enclosure and there shall be total insulation of the release with respect to the power circuit.

The microprocessor release shall measure the true rms values to make the measurement free from the influence of harmonics. The trip-time shall preferably be within 30 ms and the setting range shall cover the following:

Overload- The rated current (Ir) settings Short-circuit - adjustable from 1.5 to 10 times the rated current (Ir) with time delay setting range from Instantaneous to 0.4 sec Instantaneous - adjustable from 2 times the nominal current (In) upto the circuit breaker electro dynamical withstand. It should be possible to switch OFF the Instantaneous protection to enable total time discrimination upto the breaker breaking capacity.

Earth fault - adjustable threshold (0.2 to In) with time delay setting range from 100ms to 400ms.

Indication of type of fault (O/C, S/C or E/F) locally by LED is preferred.

Local over current pre-trip alarm is preferred by LED on microprocessor release with 2 levels:–

- (1) glowing steady when load current reaches 90% of rated current (Ir)
- (2) flashing when load current reaches 105% of rated current (Ir)

Thermal Memory: The microprocessor release shall optimize the protection of the equipment or the circuit conductors in the event of repeated overloads or faults by using thermal integration to memorize temperature rises.

Safety: Internal overheating of the microprocessor control unit shall be signalled by self monitoring alarm.

The microprocessor release shall make it possible to have full discrimination with down stream MCCBs.

Accessories:

ACB shall be provided with following accessories, if specified in schedule of quantities. Further these devices shall be field fitable from the front and common for all ratings.

- Under -voltage
- Shunt-trip
- Closing coil
- Auxiliary contacts: 4NO+4NC (provision for additional changeover switches wherever required)

Testing

Test certificate Original Test certificate of the ACB as per IS13947-2/IEC947-2 shall be provided on request.

II. Moulded Case Circuit Breakers:

i. General

Moulded case circuit breakers shall be incorporated in the PCC/MCC wherever required and shall be of current limiting type and preferably double break.

- MCCBs shall conform to IS 13947-1/IEC 947-1 for general rules and IS 13947-2/IEC 947-2 for circuit breakers in all respects.
- MCCB should be suitable for horizontal & vertical mounting and Line –Load reversibility and shall be suitable for Isolation.
- MCCB shall be suitable for three phase 690 V, 50Hz, AC with a rated insulation voltage of 750 V AC and impulse withstand of 8 kV.
- The MCCB shall be available in three & four pole version (selectable neutral protection at 0, 50% & 100%).
- The MCCB shall provide Class II insulation between the front and internal circuits.

All the breakers shall have tropicalisation as a standard feature.

Construction:

The MCCB case & cover shall be made of high strength heat resistant and flame retardant thermosetting insulating material. □ The operating handle shall be quick make, quick break trip free type. The operating handle shall have suitable 'ON', 'OFF', 'TRIPPED' indicators. □ In order to ensure suitability for isolation complying with IS13947-2/IEC947-2, the operating mechanism shall be designed such that the handle can only be in 'OFF' position.

Three phase MCCBs shall have a common operating handle for simultaneous operation and tripping of all the three phases.

It shall be possible to "seal on" the thermal-magnetic or electronic trip units to prevent unauthorized access to the settings.

It should be possible to interchange the trip units at site.

Rating & Breaking Capacity:

The rating of the circuit breaker shall be as per the and schedule of quantities.

The ACB will have minimum service breaking capacity (Ics) equal to Ultimate Breaking Capacity (Icu)

The Service Breaking Capacity (Ics) in kA for different ratings at 415V AC, 50Hz, at 0.2 p.f shall be as follows:

- 25kA for ratings upto 100A
- 35KA for ratings above 100A and upto 250A
- 45KA for ratings above 250A and upto 630A.

Protection:

All breakers upto 250A shall have thermal-magnetic trip unit with adjustable overload protection and fixed magnetic protection.

The MCCBs ratings above 250A shall be fitted with electronic trip unit. The overload setting adjustable from 40% to 100% of the nominal current(I_n).

It should be possible to have one or more LED indication(s) on the electronic release -

(1) for overload as a pre-trip alarm

- glowing at 90% of rated current (I_r).
- Flashing at 105% of rated current (I_r).

(2) Fault trip indication by LED locally on the electronic release for O/C, S/C & E/F (if supplied) wherever release with Communication option (COM) is specified.

The short circuit protection should be adjustable from 2 to 10 times the rated current (I_r). The Instantaneous Short Circuit protection to be fixed, without any time delay at 11 times the nominal current (I_n).

The Earth fault protection, if specified in schedule, shall have adjustable sensitivity with adjustable time delay settings.

It shall be possible to fully co-ordinate the over-load & short-circuit tripping of the circuit breakers with the upstream and downstream circuit breakers to provide Total Discrimination.

Accessories:

MCCBs shall be provided with the following accessories, if specified in schedule and all these devices shall be fittable at site. Each of these units shall incorporate a pre-wired terminal strip which is accessible from the front of the breaker without removing the cover. Preferably, the Shunt trip release and under voltage release shall be snap-in type.

- Under voltage
- Shunt trip
- Alarm switch
- Auxiliary switch
- Motor operated Mechanism

Interlocking:

MCCBs shall be provided with the following interlocking devices for interlocking the door of the switchboard. Handle interlock to prevent unnecessary manipulations of the breaker.

Door interlock to prevent door being opened when breaker is in ON or OFF position

Door-interlock defeat to open the door even if the breaker is in ON position.

Front operated rotary handle should have OFF-position pad-locking facility.

Testing:**Test certificate**

Original Test certificate of the MCCB as per IS13947-2/IEC947-2 shall be provided on request

DCOs

DCOs shall comply with IS 13947 1 for general rules and IS13947-4-1 for standards pertaining to contactors and motor starters. The contactor shall be capable of withstanding breaking & making capacities per following:

- AC3 Category AC4 Category
- Making Current - 10 times Rated Current 12 times rated current
- Breaking current - 8 times Rated current 10 times rated current
- Contactor shall be capable of withstanding an impulse voltage of 8KV and have an insulation voltage of 1000V.

The Contactors shall be capable of frequent switching and should operate without any degradation at 55 deg. C for AC3 application.

The coil shall have 3 terminals and the insulation class shall be preferably H class, to sustain frequent switching operations. The auxiliary contact block shall have a switching capacity of 240V at 2A.

Contactors shall have one auxiliary in-built and it shall be possible to have additional NO & NC contacts in steps of two.

III. Thermal Overload Relay

The Thermal Overload Relay (TOR) shall comply with IS 13947-1 for general rules and IS 13947-1 for standards pertaining to contactor and motor starters and shall be designed for AC3.

- The TOR shall be suitable for Type 1 and Type 2 coordination as per suitable clause in the relevant Indian Standards.
- The TOR shall be capable of offering differential protection and shall be ambient compensated type, operable upto 70 deg. C.
- The TOR shall be capable of withstanding short circuit equal to seventeen times the rated thermal current (17 Ie).
- The TOR will be tripping class 10A as a standard or class 20 for certain applications where specified.
- The TOR should have built in single phasing protection and phase unbalance protection as per IEC947-4.
- It shall be possible to mount the TOR on the underside of the contactor directly.
- The design of the terminal shroud shall be such that it offers complete protection against direct finger contact with the power terminal, as under IP 20 protection.
- The TOR shall have in built NO & NC contact.
- The "Reset" operation shall be clearly distinguished from the "Stop" operation.
- The TOR shall have separate "Stop" and "Test" button.
- The setting shall be of the adjustable type and there should be a provision of sealing to make the same tamper proof.
- The TOR shall be suitable for Aluminium termination, with a maximum permissible temperature rise of 65K, at the terminals, with an ambient temperature of 40 deg. C.

All the TORs shall have tropicalization as IEC 68 series as a standard feature.

IV. Miniature Circuit Breakers (MCB)

- MCB for ratings upto 125 Amps shall be available in 1, 2, 3 or 4 pole versions.
- MCB casing shall be made of self-extinguishing material, tropicalised treatment 2 (relative humidity: 95% at 55 degrees C).
- MCB shall comply with IS8828-1996/IEC 898-1995.

- It shall be suitable for use in frequency range 40Hz to 60Hz and shall accommodate AC/DC supply according to requirements.
 - Arc chutes should be provided for effective quenching of arc during operations and fault conditions.
 - It shall have trip free mechanism and toggle shall give positive contact indication.
 - It shall be suitable for mounting on 35mm DIN rail/ surface mounting.
 - Line supply may be connected to either top or bottom terminals i.e there shall be no line load restriction.
 - Degree of protection, when the MCB is flush mounted, shall be IP40.MCB & shall be supplied with clamping terminals fully open.
 - Contact closing shall be independent of the speed of the operator.
- MCB's operating temperature range shall be -20 deg C to + 60 deg C

The characteristics should be in accordance with IS8828-1996.The breaking capacity of the MCB shall be 10kA and energy limiting class 3.

- The rated impulse voltage U_{imp} of the MCB shall be greater than 4kV.
- The MCB shall be capable of being used as Incomer circuit breaker and shall be suitable for use as an isolator.
- Electrical endurance of the MCB should preferably be 20,000 opns.
- Power loss per pole shall be in accordance with IS8828 - 1996 and the same shall be furnished by the manufacturer.
- In case of multipole MCBs in a single location (DB), it shall be possible to remove MCB without having to disturb other MCB's in the vicinity.

1. INSTRUMENT TRANSFORMERS:

a) Current Transformers:

Current Transformers shall be in conformity with IS: 2705 (Part I, II and III) in all respects. All current transformers used for medium voltage applications shall be rated for 1.1KV, current transformers shall have rated primary current, rated burden and class of accuracy as specified in the schedule. However, the rated secondary current shall be 5 A unless

otherwise specified. The acceptable minimum class of various applications shall be as given below:

Measuring: Class I

Protection: Class 10 P.

Terminals of the current transformers shall be marked permanently for easy identification of poles. Current transformers shall be provided with Earthing terminals for Earthing chassis frame work and fixed part of the metal casing (if any). Current transformers shall be mounted such that they are easily accessible for inspection, maintenance and replacement. The wiring for CTs shall be copper conductor, PVC insulated wires with proper termination lugs wiring shall be bunched with cable straps and fixed to the panel structure in a neat manner.

V. MEASUREMENT INSTRUMENTS:

General:

The digital multi function meter has to have following features

- It show the True RMS value
- It should display Accurate on distorted waveforms
- Low PT, CT burden is essential
- CTR & PTR to be user programmable (both primary & secondary)
- It has to have Analog load bar for indicating the percentage of load through 12 LED segments
- It should have Bright 8 segment LED for better readability
- It can view 3 Parameters together
- It has to have Built-in phase analyzer
- A 10 year back-up of integrated data is desirable
- Accuracy : Class 1.0 as per IEC 62052-11, 62053-21, class 0.5(optional) as per IEC 62052-11, 62053-22 and ANSI C12.20
- Universal auxiliary supply - both AC (44-300V) and DC (44 - 300V)
- It should work for both HT or LT application
- Communication with PCs, PLCs, DCS through optional RS485 Serial Port is required
- It has to have Tamper Proof Cover
- construction has to be Sealed dust-proof
- It has to have Turbo key for quick scrolling through the pages
- It has to have Password protection for setup parameters

VI. RELAYS:

a. General

Protection relays shall be provided wherever required to trip and isolate the particular section under fault. All the relays shall be adjusted and co-ordinate for proper range of the particular circuit or equipment. Relays shall be provided with flag type indicators to indicate the cause of tripping. The flag indicators shall remain in position until they are reset by hand reset. The relays contacts shall be of silver or platinum alloy. The case shall be dust tight with a finish suitable for tropical country. The relays shall be capable of disconnecting faculty section of network or faculty equipment without causing interruption or disturbance to the remaining sections.

b. OVERCURRENT RELAYS:

Combined over-current and earth fault relays:

Over-current relays shall be induction type with inverse definite minimum time lag characteristics. The over current relays shall be provided with adjustable current and time settings. The setting for current shall be 50 to 200% in step of 35%. The IDMT over current relays shall have time lag (Delay) of 0 to 3 seconds. The time setting multiplier shall be adjustable from 0.1 to unity. Over current relays shall be fitted with suitable tripping device with trip coil being suitable for operation on 5 amperes. Earth fault relay shall have current setting of 10% to 40% in step of 10% otherwise; the earth fault relays shall conform to specification laid down for over current relays.

TESTING:

1. Instrument transformers shall be tested at factory as per IS: 2705 and IS: 3156. The test shall incorporate routine tests. Original test certificates in triplicate shall be provided.
2. Meters shall be tested as per IS: 1148. The tests shall include routine tests. Original test certificate in triplicate shall be furnished.
3. Suitable injection tests shall be applied to the secondary:
 - Circuit of every instrument to establish the correctness calibration and working order.
 - All relays and protective devices shall be tested to establish correctness of Setting and operation by introducing a current generator and an ammeter in the circuit.

1.3.1.6 Technical Specifications – Supply And Installation Of Low Voltage Cables

I. TYPE:

Low voltage cables shall be copper conductor (unless otherwise specifically mentioned for Aluminium), PVC insulated. PVC sheathed and steel wire armoured or steel tape armoured construction. The conductors of cable from 16sqmm size shall be stranded. Sector shaped stranded conductors shall be used for cables of 50sqmm size and above. The cable shall conform to IS: 1554 part - I in all respects.

The XLPE cables shall be ST HR inner sheathed ST2 - FRLS outer sheathed as per IS – 7098 (Part-1) wire stripped.

II. RATING:

The cable shall be rated for a voltage of 1100 volts.

III. CORE IDENTIFICATION:

Cores shall be provided with the following colour scheme of PVC insulation.

- 1 Core: Red/ Black/ Yellow/ Blue.
- 2 Cores: Red and Black
- 3 Cores: Red, Yellow and Blue
- 3 1 / 2 / 4 Core: Red, Yellow, Blue & Black.

IV. CABLES AND OTHER ITEMS:

- Specifications for XLPE Cables: IS 7098 - Part – I - 1988
- Specification for PVC insulated: IS 1554 - 1964 (Heavy duty) electric cables Part - I For voltage upto 1100 Volts.
- Specifications for PVC insulated: IS 694 - 1988 Cables for voltage up to 1100V Part - II With aluminium conductors.
- Glossary of terms for electrical cables: IS 1885 – 1971 and conductors.
- Code of practice for safety of buildings : IS 1646 – 1961
- (General) Electrical installation.

V. Storing:

All the cables shall be supplied in drums. On receipt of cables at site, the cables shall be inspected and stored in drums with flanges of the cable drum in vertical position.

VI. Cables in indoor trenches:

Cables shall be laid in indoor trenches wherever, specified. Suitable cables in position. Trenches shall be filled with steel checkered trench covers.

VII. Cable on Trays / racks:

Cables shall be laid on cable trays/ racks wherever specified. The cables laid shall be securely fixed to the Cable trays by means of lockable nylon ties. After laying the cables the cable shall be securely fixed by using 25x3mm GI strips and bolted to the cable tray. The cost of the nylon ties and the overlapping GI strip shall be included in to the laying cost of the cable as no separate payment will be made for the overlapping strip and nylon ties.

VIII. CABLE TERMINATIONS:

Cables jointing shall be done as per the recommendations of the cable manufacturer. Jointing shall be done by qualified cable jointers. Each termination shall be carried out using brass compressions glands and cable sockets. Hydraulic crimping tool shall be used for making the end terminations. Cable gland shall be bonded to the earth by using suitable size G.I wire / tape.

IX. CABLE TRAYS:

The cable trays shall be of ladder type / perforated steel section slotted angles as mentioned. The trays shall be complete with plates, Ts, elbows, risers, and all necessary hardware. The trays shall be galvanised as per IS 2629. The cable trays shall have suitable strength and rigidity to provide adequate support for all cables. It shall not present sharp edges, burs or projections, injurious to the insulation of the wiring and cables. The trays shall be adequately protected against corrosion and shall be made of corrosion resistant material. It shall have side rails or equivalent structural members. There shall be a continuous earth strip running on either side of the tray for earthing.

X. CABLE SUPPORT SYSTEM:

The cable tray support system shall have the appropriate factory fabricated components. It shall be with ceiling support plates anchored with the ceiling with grip bolts. The perforated trays shall be supported with threaded studs with adjustable clamps and shall have nuts and washers accessories for leveling.

i. Installation of Cables Trays :

- a. Cables trays shall be installed as a complete system. Trays shall be supported properly from the building structure. The entire cable tray system shall be rigid and leveled.

- b. Each run of the cable tray shall be completed before the installation of cables.
- c. In portions where additional protection is required, non combustible covers / enclosure shall be used.
- d. Cable trays shall be exposed and accessible.
- e. Where cables of different system are installed on the same cable tray, non combustible, solid barriers shall be used for segregating the cables.
- f. Cable trays shall be grounded by two numbers earth continuity wires. Cables trays shall not be used as equipment grounding conductors.
- g. Cable trays shall be properly leveled and aligned as per the site conditions and a proper shop drawing shall be produced before starting the work and got approved by the consultant / project manager.
- h. The installation of cable tray support system shall be using the required accessories as mentioned above and using grip bolts for proper strength in fixing.
- i. The separation distance between power and data/telecom cable tray must be between 1 to 1.5 ft

1.3.1.7 Technical Specifications: Low Voltage Systems

I. DISTRIBUTION BOARDS FOR POWER AND LIGHTING DISTRIBUTION:

i. Distribution boards shall be suitable for 415 volts, 3 phase A.C. supply of 230 volts single phase A.C. supply as required. Distribution board shall generally conform IS: 2675 or BS: 214.

ii. Type & Construction:

Distribution boards shall be of totally enclosed dead front safety type. The enclosures shall be made of the best quality sheet steel of not less than 2 mm. The sheet steel shall be treated with a rigorous rust inhibition process before fabrication. The distribution boards shall comprise of switch fuse unit or miniature circuit breakers as incoming and required number of circuit breakers or fuses as out goings. The main and out goings shall have rating as specified in the schedule. The distribution board shall be provided with suitable earthing lug.

iii. Bus Bars:

Suitable bus bars made of high conductivity, High Electrolytic grade, Solid copper and mounted on non-hydro scopic insulating supports shall be provided. Separate earth line will be provided.

II. Circuit Breakers:

Miniature circuit breakers shall be of approved design and make. Circuit breakers shall be equipped with individually insulated, braced and protected connectors. The front fact of all the breakers shall be flush with each other.

III. H.R.C. Fuses:

Rating of the fuses and carriers shall be as per schedule of quantities. Fuse carriers and bases shall be best grade phenolic mouldings conforming to IS: 1300. They shall be non-inflammable and non-deteriorating type characteristics. It shall be link type and shall conform to IS: 1108.

IV. Safety & Interlocks:

All the live parts shall be shrouded such that accidental contacts with live parts are totally avoided. Distribution boards shall be provided with a front hinged door. Distribution boards interior assembly shall be dead front with the front cover removed. Main lugs shall be shrouded. Suitable insulating barrier made of arc resistant material shall be provided for phase separation. Ends of the bus structures shall also be shrouded.

V. Cabinet design :

The distribution board cabinet shall be totally enclosed type with dust and vermin proof construction. The cabinet shall be stove enameled. The interior surface shall finished to a off-white shade. The interior components shall be mounted and locked on to the study provided inside the cabinet. Over this, a cover made of hylam sheet or stove enameled sheet shall be provided with slots for operating handle of breakers. The cabinet shall be equipped with a front door having a spring latch and vault lock. Cabinets shall have detachable gland plates at both top and bottom.

VI. Terminals:

Distribution boards shall be provided with a terminal block of adequate size to receive mains and outgoing circuits. The location of the terminal block shall be so located that crowding of wires in the proximity of live parts is avoided. A neutral link having rating equal to that phase bus shall be provided.

VII. Directory:

Distribution boards shall be provided with a directory indicating the area or loads served by each circuit breaker, the rating of breakers, size of conductors, etc. The directory shall be mounted in metal holder with a clear plastic sheet on inside surface of the front door.

VIII. Installation:

Distribution boards shall be surface mounted recessed mounted as required by the SIA and at the locations. The boards shall be fixed with suitable angle iron clamps and bolts. All the cables / conduits shall be properly terminated using gland / grips / check nuts etc., Wiring shall be terminated properly using crimping lugs/sockets & PVC identification per rules.

IX. Testing:

Distribution boards shall be tested at factory as per IS:2675 or BS: 214. The tests shall include insulation test, high voltage test, etc. Distribution boards shall be tested for insulation resistance after the erection.

X. UPS OUTPUT PANEL

The PDU should be designed for distribution of power up till rack level keeping in mind the number of termination required for the entire server farm area. There should be at least 10 percent of free MCCB in each PDU in case of failure of any connection. Two separate connections to the rack should be provisioned for the Rack power distribution, one from PDU-1 (Source UPS 1) and the other in PDU-2 (Source UPS-2).

PVC CONDUITS & ACCESSORIES:**i. CONDUITS**

General conduits shall be of PVC extruded with original mix. The wall thickness of conduits shall be as follows:-

- a. 19, 25 & 32mm – 1.5mm or 2mm thick.
- b. 38, 50mm and above - 2.5mm thick.

The PVC conduits shall conform to the requirements of IS: (latest edition) in all respects. The conduits shall have uniform wall thickness and uniform cross section throughout. The conduit shall be free from burrs. Conduits shall bear the name or trade mark of the manufacturer on each length. The conduits shall be delivered to the site in original bundles. Conduits of less than 19mm dia. Shall not be used. Conduits accessories such as bends, inspection bends, inspection tees, elbows, reducers, draw boxes, junction boxes, etc. shall be of approved makes. The conduit accessories shall conform in all respects to IS: 3837. Boxes shall have internally tapped spouts. Junction boxes / inspection boxes shall be provided with suitable covers. All conduits must be of medium duty.

ii. INSTALLATION OF CONDUITS:**• OPEN / SURFACE CONDUIT SYSTEM:**

Wherever, specifically called for, surface conduit system shall be adopted conduits shall be run in square and symmetrical lines. Before the conduits are installed, the exact route shall be at site and approval of the user shall be obtained. Conduits

shall be fixed by heavy gauge GI saddles, secured to suitable rawel plugs, at an interval of not more than 1 meter. Wherever couplers, bends couplers, bends or similar fittings are used, the saddles shall be provided on either side at a distance of 30 cm from the centre of such fittings. Conduits shall be jointed by means of screwed couplers and screwed accessories only. In long distance straight runs of conduits, inspection type couplers or running type coupler's with jam nut shall be provided. Threading shall be long enough to accommodate pipes to the full threaded portion of the couplers, and accessories. Cut end of conduits shall have no sharp edges nor any burrs left to avoid damage to the insulation of the conductors. Bends in conduit runs shall be done by bending conduits by pipe bending machine or any other suitable device as far as possible. Bends which cannot be negotiated by pipe bends, shall be accompanied by introducing solid bends, inspection bends or cast iron inspection box. The radius of solid bends shall not be less than 7.5cm. Not more than three equivalent 90o bends shall be used in a conduit running from outlet to outlet. Bends shall be properly drained and ventilated to prevent sweating or condensation inside the pipes. The entire conduit opening shall be properly plugged with PVC stoppers/bushes. The conduits shall be adequately protected against rust by applying two coats of approved synthetic enamel paint after the installation is completed.

- Wherever conduits terminate into point control box, outlet box, distribution board etc., conduits shall be rigidly connected to the box / board with check nuts on either side of the entry to ensure proper electrical and mechanical continuity. The entire conduit system after installation shall be bounded to the earth as per the specifications given in IS 732 and IS 3043.

- **RECESSED CONDUIT SYSTEM:**

All the conduits including, bends, unions, junction boxes, etc., shall be cleaned and painted with two coats of bituminous paint before they are fixed in position. Conduits which are to be taken in the ceiling slab shall be laid on the prepared shuddering work of the ceiling slab before concrete is poured. The conduits shall be properly threaded and screwed into sockets, bends, junction boxes and outlet boxes and shall be made watertight by using bituminous hemp yarn at the screwed ends. The conduits in ceiling slab shall be straight as far as possible to facilitate easy drawing of wires through them. Before conduits are laid in the ceiling the positions of outlet points, point controls, junction boxes shall be set out clearly so as to minimize offsets and bends.

Conduits recessed in walls shall be secured rigidly by means of steel hooks /staples at 0.8 meter intervals. Before conduit is concealed in the walls, all chases, grooves shall be neatly made to proper dimensions to accommodate the required number of conduits. The outlet boxes, point control boxes, inspection and draw boxes shall be fixed as and when conduit is being laid. The recessing of conduits in walls shall be so arranged as to allow at least 12 mm plaster cover on the same. All grooves, chases etc. shall be refilled with cement mortar and finished up to the wall surface before plastering of walls is taken up by the general DCO. Where conduits pass through expansion joints in the building, adequate expansion fittings or other approved devices shall be used to take care of any relative movement. Wherever conduits terminate into point control boxes, distribution boards etc., conduits shall be rigidly connected to the boxes; boards etc. with check nuts on either side of the entry to ensure electrical continuity. Running joints in conduits wherever necessary shall be rigidly held in aligned position by check nut tightened on running side. After conduits, junction boxes, outlet boxes, are fixed in position their outlets shall be properly plugged with PVC stoppers or with any other suitable material so that water, mortar, vermin or any other foreign material do not enter into the conduit system. All conduits ends terminating into an outlet, draw box, junction box, point control boxes etc., shall be provided with bushes of PVC or rubber, after the conduit ends are properly filled to remove burrs and sharp edges. Concealed conduit laying, above false ceilings shall be executed in similar manner described above. Necessary GI pull wires shall be inserted into the conduit for drawing wires and proper size earth continuity wire shall be run throughout the length of the conduit with the earth wire being efficiently fastened to the conduit by means of special clamps.

XI. ENCLOSURE FOR ELECTRICAL ACCESSORIES:

- i. Enclosure for electrical accessories such as switches, sockets, fan regulators, etc. shall be of factory moulded GI boxes conforming to IS: 5133 - Part I. The dimensions of the enclosures shall be as per clauses 3.1 to 6.31 of IS: 5133. The wall thickness of GI enclosure shall not be less than 1.6 mm. The enclosure boxes shall be provided with a minimum of four fixing lugs located at the corners for fixing the covers. all fixing lugs shall have tapped holes to take machined brass screws.
- ii. 3.2 Sufficient number of knock-outs of 38mm/ 32mm/ 25mm dia. shall be provided for conduit entries. Enclosures shall be sufficiently strong to resist mechanical damage under normal service conditions, provision shall be made for bonding the enclosures

to the earth. The enclosures shall be adequately protected against rust and corrosion both inside and outside.

XII. WIRING CONDUCTORS:

- i. All wiring conductors shall be PVC insulated, stranded aluminium conductors of 1100 V grade. Wiring conductors shall conform in all respects IS: 694 Part-II (latest edition). Wiring conductors shall be supplied in Red, Black, Yellow, Blue colours for easy identification of wires. The wiring conductors shall be supplied in sealed coils of 100 mtr length. The wiring conductors shall bear manufacturer's trade mark, name, ISI mark, voltage grade, etc.
- ii. Installation of wiring conductors/ cables: The wiring conductors shall not be drawn into the conduits / wire ways until all the works of any nature that may cause damage to the wires are completed. Proper care shall be taken in pulling the wires to see that no damage occurs to the insulation of the wires. The installation and termination of wires shall be carried out with due regard to the followings.
 - a. While drawing the wiring conductors, care shall be taken to avoid scratches and kinks which cause breakage of conductors. There shall be no sharp bends in the conduit system.
 - b. Insulation shall be shaved off like sharpening a pencil.
 - c. Strands of the wires shall not be cut for connecting to the terminals or lugs.
 - d. The terminals shall have adequate cross section to take all the strands.
 - e. Ends of the wiring conductors shall be terminated by using crimping sockets.
 - f. Soldering of sockets shall not be done. Ends of the conductors terminating into a switch / socket / connector shall be soldered.
 - g. Oxide inhibition grease shall be applied at all terminals and connections.
 - h. Brass flat washers of large area shall be used for bolted terminals.
 - i. Bimetallic connectors should be used wherever aluminium conductors are tapped from copper mains or vice-versa.
- iii. Wiring for power and lighting circuits shall be carried out separately and distinct wiring systems. Wiring for emergency system shall also be carried out in a separate and distinct wiring system. Balancing of circuits in a three phase system shall be arranged before the installation is taken up. Wiring conductors

for 3 phase, 4 wire system shall be of 1100 volts grade and that for single phase, 2 wire system shall be of 650 volts grade.

- iv. The wiring system envisaged is generally shown on the layout drawings and line diagrams. However, a brief account of the general wiring system is given below.
 - a. Sub mains wiring - wiring from switch boards to the individual distribution boards.
 - b. Circuit wiring - wiring from DBs to the point control boxes for lighting, fans, 5A sockets, etc. and from DBs to the power sockets in the case of power wiring.
- v. The sub-main wiring shall be either in 3 phase 4 wire or single phase, 2 wire system. Each sub main wiring circuit shall also have its own copper earth continuity wire. The number and size of copper earth continuity wire shall be as per the detailed drawings and specifications.
- vi. Circuit wiring shall be in single phase system. However, a maximum of 3 to 4 single circuits belonging to the same pole/phase could be installed in the same conduit or raceway.
- vii. The wiring shall be complete in looping system.

Each circuit wiring shall be provided with suitable copper earth continuity conductor. Not more than eight light points/fan points shall be grouped on one lighting circuit. The load per circuit shall not exceed 750 watts. All the wiring shall be carried out in looping-in-loop system. The maximum number of various size conductors that could be drawn into various sizes of conduits shall be as per table II of IS: 732 (Latest Edition). The wiring shall be colour coded for easy identification of phases and neutral the following colour codes shall be adopted:

Phase

R - Red

Y - Yellow/White

B - Blue

Neutral - Black

Earth - Green

- viii. All circuit wiring shall be provided with printed PVC identification ferrules at either end bearing the circuit number and designation.

- ix. Flexible conduit shall be used for dropping from ceiling complete with couplings for dropping circuits and point wiring for connecting up the lighting fixture

XIII. SWITCHES, SOCKETS AND MODULAR ACCESSORIES:

1. General Requirements: Light control switches shall be of a 5A rating. Light control switches shall be of piano-key type design suitable for flush mounting for general lighting. Wherever specifically called for tumbler type switches shall be used for surface mounting. Light control shall have either integral mounting plates or white PVC/Perspex cover plates as approved.

2. All sockets, 5A & 15A ratings, shall be of flush mounting type with control switches of piano-key type design of the same rating as that of the sockets. All sockets outlet shall be of 3 pin / 5 pin type. The socket shall be of high quality polycarbonate with pins made of brass alloy and plated with a noble metal. Sockets shall be provided with PVC surface outlet plates with round corners and beveled edges. All the sockets shall be provided with plug tops of approved quality and design.

3. Industrial type sockets: Industrial type sockets shall be provided wherever specifically called for. Industrial sockets shall be totally metal clad with porcelain base incorporating the pins. Sockets shall have 3 pins for single phase applications and 4 pins and scraping earth of 3 phase applications. The sockets shall be provided with suitable metal clad plug top with suitable cable entry. Sockets shall have metal covers with chain. It shall have a suitable interlocked switch. Industrial type sockets shall be provided with a suitable sheet steel housing made of 16 gauge with the socket mounted in flush with cover of the housing.

4. Lamp holders, ceiling roses etc. Accessories for light outlets such as lamp holders, ceiling roses etc. shall be in conformity with requirements of relevant IS specification. Only approved make of accessories shall be supplied.

5. Installation of switches, sockets & accessories: All the switches shall be wired on phases. Connections shall be made only after testing the wires for continuity, cross phase etc., with the help of a megger.

Switches, sockets fan regulators etc., shall be housed in proper GI factory boxes. The arrangement of switches and sockets shall be neat and systematic. Covers for enclosure shall be moulded accommodating switches, sockets etc., Outlets shall be terminated into a ceiling rose for fan points. For wall plug sockets, the conductor may be terminated directly into the switches and sockets.

The outlets, point control boxes etc. shall be set out as shown on the drawings. Before fixing these, the DCO shall obtain clearance from the SIA / consultant / project manager

with regard to their proper locations. The enclosure of sockets and 3rd pin of the sockets shall be connected to the ground through a proper size earth continuity wires.

XIV. POINT WIRING:

Point wiring shall commence from the first point control box/local control box for the points connected to the same circuit. Point wiring for lights, fans 5 A sockets, call bells etc. shall be carried out with PVC insulated wires. Only 2.5mm² wires shall be used. The point wiring shall be inclusive of 25mm / 32mm rigid pvc conduits of standard and approved make (as specified herein before) along with approved quality conduit accessories such as bends inspections bends, reducers, junction boxes etc. together with wiring accessories such as ceiling roses, lamp holders, connectors, point control boxes (enclosure for electrical accessories) etc., Point wiring shall be provided with 14 SWG Copper earth continuity wire for earthing 3rd pin of sockets, luminaries and fan fixtures. Light control shall be either single, twin or multiple points controlled by a switch as specified.

XV. TESTING OF ELECTRICAL INSTALLATIONS:

i. Testing of installation shall be as per IS: 732-1963.

- a. The insulation resistance shall be measured by applying suitable pressure between earth and whole system of conductors or any section thereof with all fuses in places and all switches closed and except in earthed concentric wiring all lamps in position or both poles of the installation otherwise electrically connected together, where a direct current pressure of not less than twice the working pressure provided that it does not exceed 500 volts for Medium Voltage circuits. Where the supply is derived from the three wire (A.C. or D.C.) or a poly phase system, the neutral pole of switch is connected to earth either direct or through added resistance, the working pressure shall be deemed to be that which is maintained between the outer or phase conductor and the neutral.
- b. The insulation resistance measured as above shall not be less than 50 megohms divided by the number of points on the circuits, provided that the whole installation shall be required to have an insulation resistance greater than one megaohm.
- c. Control rheostats, heating and power appliances and electric signs , if required, be disconnected from the circuit during the test but in the event of the insulation resistance between the case or frame work and all live parts of each rheostat appliances and sign shall not be less than that

specified in relevant Indian Standard Specifications or where there is no such specification shall not be less than a half mega ohm.

- d. The insulation resistance shall also be measured between all conductors connected to one pole or phase conductor of the supply and all the conductors connected to the middle wire or the neutral or to the other pole or phase conductors of the supply and its value shall not be less than specified in sub clause (b).

ii. Testing of Earth continuity path:

The earth continuity conductor including metal conduits and metallic envelopes in all cases shall be tested for electric continuity and the electrical resistance of the same along with the earthing lead but excluding any added resistance or leakage circuit-breaker measured from the connection with the earth electrodes to any point in the earth continuity conductor in the completed installation shall not exceed one mega ohm.

iii. Testing of polarity of non-linked single pole switches:

- a. In a two wire installation, test shall be made to verify that all non-linked single pole switches have been fitted in the same conductor throughout and such conductor shall be labeled or marked for connection to an outer or phase conductor or to the non-earthed conductor of the supply.
- b. In a three wire or a four wire installation, a test shall be made to verify that every non-linked single pole switch is fitted in conductor which is labeled or marked for connection to one of the outer phase conductors of the supply.

1.3.1.8 Technical Specifications – Light Fixtures

I. GENERAL :

1. The light fixture shall be as per the catalogue number specified.
2. The fixture shall be complete with the required lamp / fluorescent tube and the starting inductor.
3. The fixture shall be high P.F correction type.
4. All electronic chokes shall be with less than 8% harmonic output.
5. All this shall have proper earthing facility to take care for eddy currents.
6. The fluorescent tubes shall be TL-5 high efficiency with minimum color rendering index of 82.
7. STROBOSCOPIC EFFECT: The fixture shall have no stroboscopic effect under normal voltage conditions.
8. The normal life of fluorescent lamps shall not be less than 7500 Hours.
9. The IP classifications shall be as per IEC-529 and as follows.
 - a. Office interiors / corridors - IP-20.
 - b. The outdoor streetlights - IP-43.
 - c. Underwater fitting - IP-67.
10. The color rendering index of lamp shall be CRI-Ra 80-90.
11. The fixture shall be class 1 safety level as per IEC.
12. The fixture shall be suitable for an atmospheric temperature of 35°C.
13. For mirror optic fixtures only mat finish parabolic side reflectors shall be used and shall conform to CIBSE-LG3-1975.
14. The fixtures to be fixed to the false ceiling shall have a clip-on mechanism for fixing.
15. The fittings shall be mounted with G.I chain/2 runs of G.I. wire for hanging the fittings fixed with anchor bolt to the ceiling.
16. It shall never be fixed resting on to the grid of false ceiling or on the AC ducting.
17. All the fixtures shall be with loop in or loop out wiring facility.
18. The inter wiring of fixtures shall be with class –H insulation.

1.3.1.9 Technical Specification - Earthing System

I. GENERAL

All non-current carrying metal parts of the electrical installation shall be earthed as per IS:3043 and with subsequent amendments. All metal conduits, trunkings, cable sheathes, switchgear, distribution boards, meters, light fixtures, fans and all other metal parts forming part of the work shall be bonded together and connected by two separate and distinct conductors to earth electrodes. Earthing shall also be in conformity with the provisions of rules 32, 61, 67 and 68 of IER-1956.

II. EARTHING CONDUCTORS

All earthing conductors shall be of high conductivity copper or GI as required /specified and shall be protected against mechanical damage and corrosion. The connection of earth continuity conductors to earth bus and earth electrode shall be strong and sound and shall be easily accessible. The earth conductors shall be rigidly fixed to the walls, cable trenches, cable trays or conduits and cables by using suitable clamps.

1. Main earth bus shall be taken from the main medium voltage panel to the earth electrodes. The number of electrodes required shall be arrived at taking in to consideration the anticipated fault on the medium voltage network.
2. All the sub-mains and sub-circuits shall be provided with earth continuity conductors as specified and connected to the main earth bus. Earthing conductors for equipment shall be run from the exposed metal surface of the equipments and connected to a suitable point on the sub-main or main earthing bus. All switch boards, distribution boards and isolators, disconnect switches shall be connected to the earth bus. Earthing conductors shall be terminated at the equipment using suitable lugs, bolts, washers and nuts. All conduits, cable armouring, raceways, rising mains, metal boxes, panel boards etc., shall be connected to the earth all along their run by earthing conductors of suitable cross sectional area. Sprinkler pipes, water pipes, steel structural elements, lighting conductors shall not be used as a means of earthing an installation. The electrical resistance of earthing conductors shall be low enough to permit the passage of fault current necessary to operate a fuse / protective device / a circuit breaker and shall not exceed 10hm.

III. EARTHING ELECTRODES

- i. PLATE ELECTRODE

Plate electrodes shall be made of copper plate of 3.15 mm thick and 60 x 60 cm size. The plate shall be buried vertically in ground at a depth of not less than 2 meters to the top of the plate, the plate being encased in salt and charcoal to a thickness of 15 cm all round. It is preferable to bury the electrode to a depth where subsoil water is present. Earth leads to the electrode shall be laid in a GI pipe and connected to the plate electrode with brass, bolts, nuts and washers. A GI pipe of not less than 25mm dia. Shall be placed vertically over the plate and terminated in a funnel at 5 cms above the ground. The funnel shall be provided with a wire mesh. The funnel shall be enclosed in a masonry chamber of 45 cm x 45 cm x 30 mm dimensions. The chamber shall be provided with heavy duty C.I.cover and C.I. frame. The earth station shall also be provided with a suitable permanent identification using painting.

ii. PIPE ELECTRODE

Pipe electrode shall comprise of a 3 mtr long 38mm dia class 'B' GI pipe buried vertically in a pit of 35cm x 35 cm size and filled with alternate layers of charcoal, salt and connected at the top to a Class 'B' GI pipe of 25mm, 1 meter long with a funnel at the other end, 5 cms above the ground. The earth lead shall be properly bolted to the pipe electrode with brass bolts, nuts and washers. The funnel and earth lead connections shall be enclosed in a masonry chamber of 30m cms x 30 cms. 300 dimensions. The chamber shall be provided with heavy duty C.I. cover and C.I. frame. Proper permanent identification tag / label shall be provided for each electrode using painting.

iii. EARTH MAT :

The earth mat shall be provided as per the sketch and as detailed in drawing.

IV. PRECAUTIONS

Earthing system shall be mechanically robust and the joints shall be capable of retaining low resistance, even after passage of fault currents. Joints shall be welded, bolted or double-reveted. All welded joints are painted with cold Zinc galvanising paint. All the joints shall be mechanically and electrically, continuous and effective. Joints shall be protected against corrosion.

V. TESTING

On the completion of the entire installation, test on earth resistance of electrode shall be conducted.

1 All meters, instruments and labour required for the tests shall be provided by the DCO. The test results shall be submitted in triplicate to the SIA / consultants / project manager for approval. Tests shall be conducted in the presence of Engineer-in-charge.

1.3.1.10 Technical Specifications – Change Over Switch for PAC

PAC changeover switch will accept two inputs from two different panels and provide one output to the PAC. This is basically to build 100% redundancy of power for the PAC. The COS will be consisting of the following

- 2 nos 60A (min) 4P AC3 Contactor with Mechanical Interlock.
- 2 nos No. ON delay Timers
- 1 No. Auto Manual Selector Switch
- Sets of On/ Off Push button.
- 1 No. Priority Selector Switch.
- No. 2NO+2NC Aux. Contactors for Status indication to BMS.
- Sets of RYB Phase Indication Lamps.
- Sets of ON/OFF Indication Lamps.
- 1 Set of Control Terminal Blocks.

1.3.1.11 Technical Specifications – Air Conditioning

1.3.1.11.1 Precision Air Conditioning

I. Precision Air conditioner units

I. Precision Air conditioner units

The Precision Air conditioner shall be High sensible cooling capacity and high SHR (i.e. the sensible to total cooling capacity ratio). Low running costs, achieved by means of sophisticated design and co-design methods, combined with an accurate selection of the components. The whole range of units shall be “environment friendly” because it uses materials that can be recycled, particularly for the plastics and the thermal insulation. The rating required is 12Tr sensible capacity with min 7000 cfm for each. Total no of PAC required is 6 nos.

II. Cabinet Construction

All versions shall be enables to access all the main components of the machine from the front for installation purposes and routine servicing. With this feature, the machines can be installed side by side, or in between cabinets for other technical applications (racks). Outside panels shall be coated with epoxy-polyester paint, which guarantees the long-term durability of their original features. The front panels are attached to the framework by means of rapid-coupling “fasteners”. The standard panels are lined on the inside with heat- and sound-proofing insulation to class 1.

III. Fans

Aluminium single-inlet centrifugal fans with backward curved blades with a low moment of inertia and innovative vane profile shall be provided. The directly-coupled electric motor is of the three-phase (or single-phase in outside-rotor type protection grade IP10, offering the opportunity for speed adjustment by means of an auto-transformer and complete with thermal protection inside the electric motor winding. Using this type of fan with a highly-reactive fan wheel instead of the one with forward curved blades enables you to reach higher useful static pressures (up to 350 Pa) AS A STANDARD FEATURE.

IV. Evaporator Coil

Heat exchanger (evaporator coil) shall be designed with an ample front surface area in order to ensure a low air flow velocity through the exchanger so as to prevent the entrainment of droplets of condensation, reduce the air's load losses and ensure a more efficient heat exchange during both the cooling and the dehumidifying processes.

The exchanger is composed of copper tubes mechanically expanded on aluminium fins, complete with a hydrophilic treatment to reduce the surface tension between the water and the metal surface, thus favoring film-wise condensation.

The exchanger is situated upstream from the fans to ensure unhindered air distribution and is complete with a stainless steel condensate tray with a flexible conduit for its drainage and an incorporated trap.

V. Filtration

Air filters of box type, made of self-extinguishing, artificial-fiber cellular material or dry media G4 type Filter. Low airflow and clogged filter alarm sensors for controlling the operating conditions of the fans and the build-up of dirt on the air filters inside the unit.

VI. Compressor

Latest-generation hermetic scroll compressors (air- and water-cooled DX versions), characterized by a high COP (coefficient of performance) and consequently also a high energy efficiency.

VII. Refrigerating circuits (air-cooled DX versions)

Each circuit is composed of as standard, a fluid intake complete with a rotalock on-off cock and safety valve, a dehydrating filter and flow sensor. The former enables the refrigerating circuit to be kept free of humidity (thus increasing the life of all the circuit's components), while the latter enables a rapid check on whether the system is charged with refrigerant correctly and whether it contains any humidity.

Electronic Expansion Valve (EEV) / Thermal expansion valve (TEV) This enables to adjust the flow of refrigerant fluid through the evaporator, controlling the real evaporator superheating in relation to variations in the ambient conditions in the room being air-conditioned. Improving in this way precision of cooling and the energy efficiency of the cooling cycle.

Liquid receiver with safety plug installed inside the unit (in the air-cooled DX versions)

VIII. Remote air-cooled condenser

These condensers are characterized by a single- or dual-circuit exchanger with aluminium finned copper tubes, complete with low-speed axial-flow fans to reduce the sound pressure level. The frame is made of embossed aluminium with excellent weather-resistant characteristics. The remote condenser is complete with an electric power and control board, fully wired and tested at the factory. Condensers shall be suitable for 24 hours operation and be capable of providing vertical or horizontal discharge

IX. Electrical Heating

Electric heating with aluminium-finned heating elements, complete with safety thermostat for manual resetting to cut off the power supply and trigger the alarm in the event of overheating. Thanks to the low surface temperature of the heating elements, the air ionization effects are also limited. This heating system serves a dual purpose: heating the air in order to reach and maintain the set point; reheating in the dehumidifying phase, so as to restore the air temperature to the set point. As a result, the installed heating capacity is sufficient to maintain the dry bulb temperature in the room during operation in dehumidifier mode.

X. Humidifier

Immersed-electrode humidifier for modulating sterile steam production with the automatic regulation of the concentration of salts in the boiler to allow for the use of untreated water. Proportional control of the humidifier's operation (achieved by controlling the electric current allowed to pass through the cylinder's electrodes) and the periodic flushing cycle (controlled by continuously monitoring the water's conductivity) guarantee a perfect efficiency of the system, a low energy consumption and a greater durability of the components.

XI. Switch Board

Switchboard shall be situated in a compartment separated from the air flow and made in compliance with the directive 73/23/EEC and related standards. The main characteristics are 24V ac low-voltage secondary circuit with isolation transformer, plastic insulating screen for protection from live components, general isolator with mechanical interlock, thermo magnetic circuit-breakers for protection, terminal board for no-voltage signal and control contacts. All the units must undergo a safety test cycle to check the continuity of the protection circuit and the insulation resistance, and a voltage (dielectric strength) test.

XII. Microprocessor control system

The microprocessor controller manages the unit operations autonomously. In direct expansion unit the algorithm permits integral management of the EEV/ TEV with consequent optimisation of energy saving, constant air flow during dehumidification and absolute operating stability. Units have been designed and developed to interact with all the most widely used Building Management Systems, exchanging data via the most common communication protocols through serial connections.

The user terminal is fitted with a backlit LCD display and keys to move between and change parameters. It can be situated on board the machine or, on request, with a kit for wall mounting for the remote control of the unit. By means of the user terminal one can set the air-conditioner's operating parameters, monitor the trend of the main working parameters and read any alarm messages.

The microprocessor control system can be supplied with the following optional cards:

- RS485 serial adapter for data transfer to a central supervisor system with STD protocol or MODBUS protocol;
- Clock card for managing scheduling operations and for the operations counter functions
- WATER LEAK DETECTOR comprising a control module installed on the electric switchboard and an external sensor.20

1.3.1.11.2 Technical Specifications – Comfort AC

Supply/ Installation/ testing and commissioning of various type of ACs such as window type, Cassette Type individual AC of and Multi split AC of suitable nominal cooling capacity fitted with hermetically sealed compressors operating on R-22/ Non CFC suitable for Ceiling Mounting, comprising of ½ room units and one no condensing units suitable for operation on 230 V, 50 Hz, single phase, or 415 V, 50 Hz, three phase, AC, supply complete with remote control, capable of performing

- Cooling
- Dehumidifying
- Air Circulating
- Filtering

Installation of AC includes:-

Mounting / Fitting indoor & outdoor unit at their respective location.

Laying Refrigerant pipelines as required at site and connecting both the unit after drilling hole/holes in the wall. The thickness of Cu tubing shall not be less than 0.80 mm.

Insulating the suction pipe with expanded polythene foam tubing.

Supply & Installation of drain pipe, to drain out the condensate water being formed in the indoor unit.

Charging of Refrigerant gas in the unit.

Provision for PVC/ Plastic channel for concealing the channel and painting matching with interiors.

Drain pipe.4 / 6 sq mm 3 / 4 core PVC insulated copper wire as per requirement to electrically connect both the units with each other.

Required plumbing for drain pipe

1.3.1.12 Technical Specification – Integrated Building Management System SECTION – I

INTEGRATED BUILDING MANAGEMENT GUI SOFTWARE

Integrated Building Management GUI software shall be high-performance, building automation system for monitoring and managing building's devices and systems, including HVAC, lighting, hydraulics, water, electrical equipment and more. An application of Buildings Integrator platform utilizes open system standards to seamlessly integrate every control and information system within the facility / enterprise.

Buildings Integrator platform shall have single-window control over all building operations, and all the relevant data which need to maximize building performance. In addition, Building Manager captures current and historical data for advanced analysis and reporting and will install, customize, and maintain Building Manager to all requirements to create the ideal solution for a wide range of operations.

Specification

Total integration of Access Control, Security, Surveillance, Heating Ventilation and Air Conditioning, Energy Management and Life Safety systems

- Integration with a diverse range of devices, enterprise systems, Internet and intranet sources allowing intelligent management of key facility information
- Uses industry-standard hardware and Windows XP, 2000 and 2003 operating systems
- Supports the leading open standards: BACnet, ODBC, and Modbus
- UL Listed to Standards UL864 (Fire), UL2017 (Signaling Systems), UL916 (Energy Management Systems), UL1017, UL1076 (Security), UL1610 (Central Station) and UL294 (Access Control)
- Easy-to-use Web-based user interface reduces operator training costs and puts the user in control of every situation
- Suitable for use in a restricted Pharmaceutical environment requiring conformance to 21 CFR Part 11 for electronic records and electronic signatures
- Designed and developed to International Standards ISO 9001 for quality

Seamless integration

I. BUILDING MANAGEMENT

Enterprise Buildings Integrator platform shall meet building management and monitoring of PAC control needs by providing interfaces to leading open system solutions and HVAC devices.

II. SECURITY MANAGEMENT

Enterprise Buildings Integrator platform collects information from security, access control and surveillance devices, ensuring protection of people, assets and intellectual property.

III. LIFE SAFETY MANAGEMENT

Enterprise Buildings Integrator platform allows monitoring and control of fire alarm systems for fire protection and smoke control. Enterprise Buildings Integrator platform shall available with UL864 Listing for Ethernet based life safety control and monitoring.

IV. DIGITAL VIDEO MANAGEMENT

Enterprise Buildings Integrator platform allows surveillance of your facility using cameras connected directly to your LAN, enabling flexible event based recording and viewing.

V. ENERGY MANAGEMENT

Enterprise Buildings Integrator platform monitors, validates and optimizes your energy usage enabling you to help the environment while saving money.

1. SYSTEM ARCHITECTURE

Enterprise Buildings Integrator platform has client/server architecture. It provides a scaleable system that accommodates configurations ranging from a small single-node system to an extended system with multiple servers and Stations connected across LANs or WANs.

Distributed System Architecture

Enterprise Buildings Integrator platform Servers can also be connected together in a Distributed System Architecture, allowing very large or geographically distributed sites to be operated as a single system. Alternatively, this architecture allows autonomous Enterprise Buildings Integrator platform nodes to communicate alarms and cardholder information through a network with a minimum of engineering effort.

A Distributed System Architecture enables multiple facilities to be operated in an efficient and consistent way across your entire organization without sacrificing the independence of each office.

In addition seamless system Integration, Enterprise Buildings Integrator platform provides an open system architecture which combines a variety of controllers, standard hardware devices, and communications interfaces into one, integrated, central system that maximizes the performance of your building or facility. Enterprise Buildings Integrator platform can integrate with the following subsystems:

- Access controllers and access card readers
- Security monitoring
- HVAC monitoring and control
- Life safety monitoring and control
- Energy usage monitoring
- Lighting control
- Analog CCTV systems
- LAN/WAN based Digital Video Manager
- Industrial process controllers
- Enterprise management systems
- Time and attendance
- Asset and people tracking
- Maintenance management
- Web, Internet and intranet pages and systems
- Alarm paging and SNMP notification systems

2. OPEN SYSTEMS SUPPORT

In addition to being based on a range of open technologies, It supports a wide variety of open systems. Standards for integrating other systems or subsystems. The Open System standards supported are listed in the following sections.

BACnet; Supports ASHRAE Standard for the BACnet Protocol, implementing both BACnet Operator Workstation and BACnet Gateway functionality. It supports BACnet over Ethernet and IP communications. A BACnet PICS document is available on request which details It support for BACnet Standard Objects and Application Services.

OPC: Supports OLE for Process Control (OPC) 2.0 Data Access. This interface allows reading and writing to an OPC Data Server as an OPC client. This capability provides access to a wide range of third-party OPC Data Servers.

MODBUS; Support general-purpose interface and de factory standard communications protocol that can be used to integrate different controllers.

3. OPERATOR INTERFACE

The operator interface allows a user to perform the following tasks:

- Display and control field equipment
- Acknowledge alarms on a priority basis
- Display point status and history information
- Display information about cardholders
- Define and alter time schedules
- Initiate printing of reports
- View, archive and retrieve event logs
- Monitor data communications channels
- Configure system parameters
- Select and control CCTV cameras
- Build points
- Create color graphic displays
- Display information from Internet and intranet sites
- Record and play back digital video
- View and track moving assets or people

Responding to alarms is crucial and an operator always needs to see the most important alarm. In Station, there is a dedicated alarm line which indicates the most recent, highest priority, unacknowledged alarm.

Stations also display status information, including:

- All points of a certain type in a particular state
- Points in alarm pending acknowledgment
- Points in alarm which have been acknowledged
- Communication failures
- Stations and printers currently off-line
- Fire detection points status

4. HMIWeb

Custom displays are created using HMIWeb Display Builder. A typical custom display includes a static background, and dynamic objects that indicate the status and alarm condition of relevant devices. Popup faceplates showing more information about a device can also be used. Also, controls, such as buttons, can be added so that users can execute tasks, call up other displays and generate reports. The HTML format of custom displays provides easy interoperability with other Web technology.

- **Web Enabled**

HMIWeb displays make use of Web technologies. Not only can they be created with native HTML content, they can be viewed in either Station or in Windows Internet Explorer. Full control of your facility is possible through a browser.

- **Operator Security:** Offers sophisticated methods for controlling access to sensitive data.

Security and Control Levels, it is possible to restrict and control what activity operators can perform by giving them different security levels. The system supports six different levels of operator security. In addition to this; this incorporates control levels to limit manual control of doors, locks or sensors. Only operators with appropriate control levels can issue commands to these points and can also restrict the commands an operator can issue, for example an operator may be allowed to lock a door but not unlock it.

- **Compliance to 21 CFR Part 11**

In highly regulated environments such as Pharmaceutical processing plants, a supervisor must formally approve any changes to a validated environment. It provides supervisors the ability to review and approve changes to the system configuration using electronic signatures. An electronic signature can be either a single or a double signature and "signing" requires operators to re-enter their password along with reasons and meanings behind the change in the system.

5. Schedules

Schedule shall provide extensive scheduling functions both from the server itself and from controller-specific schedules. Occupancy scheduling can be defined by selecting the appropriate dates and times from a simple calendar display. A single Software schedule can define system behaviour on any weekday, weekend or holiday. In addition, a special occasion schedule can be applied to override the normal occupancy schedules to handle special events.

Point Groups

It can group points based on alarm inputs, outputs, controller, area, doors, or elevators. An operator can then control a group or monitor it as one entity. A summary display shows information about the groups, including the number of points in a group and the number of points in each state.

Event Initiated Programs allows the triggering of additional controls or system functions from input points. When the input point changes state, this may cause a range of actions such as:

- Displaying cardholder information when a card is presented at a reader
- Enabling output controls based on a logical combination of inputs
- Alarming a master point based on the alarm states of subordinate points
- Averaging a set of temperatures into the value of one point
- Process shutdown based on critical fire or utility alarm

6. ALARM MANAGEMENT

The comprehensive alarm management facility should ensure that operators are immediately notified of any attempted security violations or building anomalies. Operators can easily respond to alarms and quickly find relevant information by using the dedicated function keys. To acknowledge, user should be able to use the mouse to select the alarm point on the display and press the Acknowledge key to acknowledge the alarm. This action will automatically be recorded in the system event file and, optionally, on an alarm printer. To get Alarm Summary, user should be able to Press the Alarm Summary key at any time to view a display showing all currently active alarms. The alarm messages should be color-coded to show priorities. From the summary display, operator should be able to acknowledge alarms and access an associated display defined for each point. Operator should be able to sort alarms or filter only for certain characteristics.

It should offer annunciates alarms as follows:

- Audible Tone. The audible tone is based on a *.wav file on each Station.
- Alarm Line. A dedicated alarm line appears on all displays and shows the most recent, highest priority, unacknowledged alarm in the system.
- Alarm Indicator. An alarm indicator appears on all displays and flashes when there are any unacknowledged alarms.
- Alarm Summary Display. An alarm summary display shows all alarms in the system and color-codes them to indicate priority and severity.
- Alarm Printer Output. Alarm messages are printed on the alarm printer for a hard copy record. Alarms annunciate at Stations even if no user is currently signed on. Even if Station is minimized, the audible tone sounds and the Station icon flashes to indicate that there is an alarm. Alarms can drive an external communicator such as a light or siren. Alarms can be associated with different point states for digital points or special conditions such as high or low values or rates of change for analog points. Each alarm is assigned a different priority: journal, low, high or urgent. Each alarm priority supports up to 15 sub-priorities within it. This allows for sophisticated alarm prioritization. Alarms can easily be sorted and filtered. It is possible to automatically elevate an alarm to the next highest priority level or

generate an additional alarm if an operator does not acknowledge an alarm within a certain time; ensuring alarms are always handled promptly.

- Alarm Pager: Alarm Pager is an additional option which allows alarms to be routed to pagers, mobile phones, email and SNMP managers.

7. EVENT MANAGEMENT

Events include alarms, point changes of state, cardholder movements, changes in system status and all operator actions. As system events occur, creates a journal of the events in an event file. Journalized event entries include a description, condition, message, time of occurrence, and responsible operator. The system event file stores event data in an on-line buffer. It is possible to store as many events as necessary—subject only to disk space on the server. When the on-line buffer becomes full, it transfers the event data to an archived buffer and notifies the operator to save the file to external media. The on-line buffer can continue to store events without interruption. An operator can retrieve current or archived system event data for use on-line or in the reports.

8. HISTORY AND TRENDING

This provides continuous history about how points in the system have been behaving over time. It can sample and store analog and status point values as historical data. Supports a range of different history collection rates. Both snapshots and averages are collected, allowing operator to view what was happening on the system at any instant in time or over a longer period. This historical data can be viewed in several ways, for example as graphical trends (such as line or bar charts) and as lists of numeric values. Historical data can also be used in reports, application programs and archived to offline media for long term storage.

Trend displays can display historical data for up to eight points, and can also plot two sets of data against each other (X-Y plots). The number of historical samples and ranges of each trend display can be configured. Operators can zoom in on trends for closer inspection, and scroll forwards or backwards in time. Operators can even copy and paste trend data directly into Microsoft Excel.

REPORTING provides comprehensive reporting facilities including a range of standard reports, the ability to create custom reports, the ability to export and import information and the ability to use other standard reporting systems.

Some examples of reporting are as follows:

- All points in alarm over a configurable time period
- All activities by a certain operator
- All activities for a certain group of points

- All movements of cardholders through certain doors
- All movements through any doors by a specified cardholder
- All information pertaining to access configuration information
- All engineering cross references for points
- All information about a group of cardholders
- How often a point has changed state
- How many times a cardholder has used a card
- All cardholders in a specific area

SECTION – II

1.1.1.1. Specification for Building Management System Open Systems Using Native BACnet

PART 1 – TECHNICAL SPECIFICATION FOR BMS

I. OPEN, INTEROPERABLE INTEGRATED ARCHITECTURE

The intent of this specification is to furnish a totally Native bacnet-based Integrated Building Management system, including an operator's workstation using Microsoft Windows 2000 Professional or XP Professional as the operating system and shall be based on a distributed control system in accordance with this specification. The Operator's workstation, all building controllers, application controllers, and all Input/output devices shall communicate using the protocols and network standards as defined by ANSI/ASHRAE Standard 135–2004, bacnet. In other words, all Workstations and controllers, including unitary controllers, shall be Native bacnet devices. No gateways shall be used for communication to controllers installed under this section. The supplied computer software shall employ object-oriented technology (OOT) for representation of all data and control devices within the system. In addition, adherence to industry standards including ANSI / ASHRAE™ Standard 135-1995, the system should be native bacnet to assure interoperability between all system components is required. For each bacnet device, the device supplier must provide a PICS document showing the installed device's compliance level; with the ability to support data read and write functionality. Physical connection of bacnet devices shall be via Ethernet or bacnet MSTP network. All components and controllers supplied under this contract shall be true "peer-to-peer" communicating devices. Components or controllers requiring "Master to Slave communication" by a host to pass data shall not be acceptable. The supplied system must incorporate an Open Database Connectivity (ODBC) or Structured Query Language (SQL) compliant server database is required for all system database parameter storage. This data shall reside on a supplier-installed server for all database access.

A hierarchical topology is required to assure reasonable system response times and to manage the flow and sharing of data without unduly burdening the customer's internal Intranet network. Systems employing a "flat" single tiered architecture shall not be acceptable.

Maximum acceptable response time from any alarm occurrence (at the point of origin) to the point of annunciation shall not exceed 5 seconds for network connected user interfaces.

Gateways may be used for communication to existing systems or to systems installed under other sections.

Provide all necessary bacnet-compliant hardware and software to meet the system's functional specifications. Provide Protocol Implementation Conformance Statement ***(PICS) for Windows-based control software and every controller in system, including Unitary controllers.***

Prepare individual hardware layouts, interconnection drawings, and software configuration from project design data.

Implement the detailed design for all analog and binary objects, system databases, Graphic displays, logs, and management reports based on control descriptions, logic Drawings, configuration data, and bid documents.

Design, provide, and install all equipment cabinets, panels, data communication network cables needed, and all associated hardware. Provide and install all interconnecting cables between supplied cabinets, application Controllers, and input/output devices.

Provide and install all interconnecting cables between all operator's terminals and peripheral devices (such as printers, etc.) supplied under this section.

Provide complete manufacturer's specifications for all items that are supplied. Include Vendor name of every item supplied.

Provide supervisory specialists and technicians at the job site to assist in all phases of system installation, startup, and commissioning.

Provide a comprehensive operator and technician training program as described herein.

Provide as-built documentation, operator's terminal software, diagrams, and all other Associated project operational documentation (such as technical manuals) on approved Media, the sum total of which accurately represents the final system. Provide new sensors, dampers, valves, and install only new electronic actuators. No used Components shall be used as any part or piece of installed system.

II. SYSTEM DESCRIPTION

A distributed logic control system complete with all software and hardware functions

Shall be provided and installed. System shall be completely based on ANSI/ASHRAE Standard 135-2004, bacnet. This system is to control all mechanical, electrical & other Equipments, including all unitary equipment such as VAV boxes (If Any), heat pumps, Fan-coils (If Any), AC units (If Any), etc. And all air handlers, boilers, chillers, and any Other listed equipment using native bacnet-compliant components. Non-bacnet compliant or proprietary equipment or systems (including gateways) shall not be Acceptable and are specifically prohibited.

Operator's workstation software shall be Microsoft Windows 2000 Professional or XP Professional as the computer operating system. The Building Management System (BMS) application program shall be written to communicate specifically utilizing Bacnet protocols. Software shall include password protection, scheduling (including Optimum start), alarming, logging of historical data, full graphics including animation, after-hours billing program, demand limiting, full suite of field engineering tools including graphical programming and applications. Systems using operating systems other than that described above are strictly prohibited.

Building controllers shall include complete energy management software, including scheduling building control strategies with optimum start and logging routines. All energy management software and firmware shall be resident in field hardware and shall Not be dependent on the operator's terminal. Operator's terminal software is to be used for access to field-based energy management functions only. Provide zone-by-zone Direct digital logic control of space temperature, scheduling, runtime accumulation, Equipment alarm reporting, and override timers for after-hours usage.

All application controllers for every terminal unit (VAV, HP, UV, etc. If any) air handler, All central plant equipment and any other piece of controlled equipment shall be fully programmable. Application controllers shall be mounted next to controlled equipment And communicate with building controller via bacnet/ MSTP LAN.

III. QUALITY ASSURANCE

The bidders should be ISO 9001 & 14001 certified and should have quality program for their organization in place.

Responsibility: The supplier of the BMS shall be responsible for inspection and Quality Assurance (QA) for all materials and workmanship furnished.

Component Testing: Maximum reliability shall be achieved through extensive use of High-quality, pre-tested components. Each and every controller, sensor, and all other DDC components shall be individually tested by the manufacturer prior to shipment.

Tools, Testing and Calibration Equipment: The BMS supplier shall provide all tools, Testing, and calibration equipment necessary to ensure reliability and accuracy of the System.

IV. REFERENCE STANDARDS

The latest edition of the following standards and codes in effect and amended as of Supplier's proposal date, and any applicable subsections thereof, shall govern design and Selection of equipment and material supplied:

1. American Society of Heating, Refrigerating and Air Conditioning Engineers (ASHRAE).
2. ANSI/ASHRAE Standard 135-2004, bacnet.
3. UL 916 Underwriters Laboratories Standard for Energy Management Equipment Canada and the US.

City, country, state, and federal regulations and codes in effect as of contract date. Except as otherwise indicated the system supplier shall secure and pay for all permits, Inspections, and certifications required for his work and arrange for necessary approvals By the governing authorities.

V. SUBMITTALS

Drawings

1. The system supplier shall submit engineered drawings, control sequence, and bill of Materials for approval.
2. Drawings shall be submitted in the following standard sizes: 11" x 17" (ANSI B).
3. Eight complete sets (copies) of submittal drawings shall be provided.
4. Drawings shall be available on CD-ROM

System Documentation

Include the following in submittal package:

1. System configuration diagrams in simplified block format.
2. All input/output object listings and an alarm point summary listing.

3. Electrical drawings that show all system internal and external connection points, Terminal block layouts, and terminal identification.
4. Complete bill of materials, valve schedule and damper schedule.
5. Manufacturer's instructions and drawings for installation, maintenance, and operation of all purchased items.
6. Overall system operation and maintenance instructions—including preventive Maintenance and troubleshooting instructions.
7. For all system elements—operator's workstation(s), building controller(s), application Controllers, routers, and repeaters, provide bacnet Protocol Implementation Conformance Statements (PICS) as per ANSI/ASHRAE Standard 135-2004.
8. Provide complete description and documentation of any proprietary (non-bacnet) Services and/or objects used in the system.
9. A list of all functions available and a sample of function block programming that shall be part of delivered system.

VI. WARRANTY

Warranty shall cover all costs for parts, labor, associated travel, and expenses for a period of one year from completion of system acceptance.

Hardware and software personnel supporting this warranty agreement shall provide onsite Or off-site service in a timely manner after failure notification to the vendor.

PART 2 – PRODUCTS

I. OPERATOR'S WORKSTATION

General structure of workstation interaction shall be a standard client/server relationship. Server shall be used to archive data and store system database. Clients shall access server for all archived data. Each client shall include flexibility to access graphics from server or local drive. Server shall support a minimum of 40 clients simultaneously.

Bacnet Conformance

- i. Operator's workstation shall as a minimum support Point-to-Point (PTP) and Ethernet Bacnet LAN types. It shall communicate directly via these bacnet lans as a native Bacnet device. Operator's terminal shall comply with the requirements of a bacnet Conformance class 3 (or higher) device and support all bacnet services necessary to Provide the following bacnet functional groups:
 - a. Clock Functional Group
 - b. Event Response Functional Group

- c. Time Master Functional Group
 - d. Device Communications
- ii. Bacnet Functional Groups as mentioned shall comply with bacnet standard for complete list of the services described. All proprietary services, if used in the system, Shall be thoroughly documented and provided as part of the submittal data. All necessary Tools shall be supplied for working with proprietary information.
- iii. Standard bacnet object types accessed by the workstation shall include as a minimum: Analog Value, Analog Input, Analog Output, Binary Value, Binary Input, Binary Output, Calendar, Device, Event Enrollment, File, Notification Class, Program and Schedule Object types. All proprietary object types, if used in the system, shall be thoroughly documented and provided as part of the submittal data. All necessary tools shall be supplied for working with proprietary information.
- iv. The Operator Workstation shall comply with Annex J of the bacnet specification for IP connections. This device shall use Ethernet to connect to the IP internetwork, while using the same Ethernet LAN for non-IP communications to other bacnet devices on the LAN & must support interoperability on wide area networks (WAN) and campus area Networks (CAN). Workstation shall support Foreign Device Registration to allow Temporary workstation connection to IP network.
- a. Displays**
- i. Operator's workstation shall display all data associated with project as called out on Drawings and/or object type list supplied. Graphic files shall be created using digital, full Color photographs of system installation, autocad or Visio drawing files of field Installation drawings and wiring diagrams from as-built drawings. Operator's workstation shall display all data using Two-dimensional graphic representations of all mechanical Equipment. System shall be capable of displaying graphic file, text, and dynamic object Data together on each display and shall include animation. Information shall be labeled with descriptors and shall be shown with the appropriate engineering units. All Information on any display shall be dynamically updated without any action by the user.
- Workstation shall allow user to change all field-resident EMCS functions associated with the project, such as setpoints, weekly schedules, exception

schedules, etc. From any Screen no matter if that screen shows all text or a complete graphic display. This shall be done without any reference to object addresses or other numeric/ mnemonic indications

- ii. All displays and programming shall be generated and customized by the local BMS Supplier and installer. Systems requiring factory programming for graphics or DDC logic are specifically prohibited.
- iii. Binary objects shall be displayed as ACTIVE/ INACTIVE/ NULL or with customized text. Text shall be justified left, right or center as selected by the user. Also, allow Binary objects to be displayed as individual change-of-state graphic objects on the display Screen such that they overlay the system graphic. Each binary object displayed in this manner shall be assigned up to two graphic files for display when the point is ON, OFF or in alarm. For binary outputs, toggle the object's commanded status when the graphic Item is selected with the system mouse. Similarly, allow the workstation operator to
Toggle the binary object's status by selecting with the mouse a graphic of a switch or Light, for example, which then displays a different graphic (such as an "ON" switch or Lighted lamp). Additionally, allow binary objects to be displayed as an animated graphic.
Animated graphic objects shall be displayed as a sequence of multiple graphics to Simulate motion. For example: when a pump is in the OFF condition, display a stationary Graphic of the pump. When the operator selects the pump graphic with the mouse, the Represented object's status is toggled and the graphic of the pump's impeller rotates in a Time-based animation. The operator shall be able to click on an animated graphical Object or switch it from the OFF position to ON, or ON to OFF. Allow operator to change Graphic file assignment and also create new and original graphics online. System shall be supplied with a library of standard graphics, which may be used unaltered or modified by the operator. Systems that do not allow customization or creation of new graphic objects by the operator (or with third-party software) shall not be allowed.
- iv. Analog objects shall be displayed with operator modifiable units. Analog input objects May also be displayed as individual graphic items on the display screen as an overlay to the system graphic. Each analog input object may be assigned a minimum of five Graphic files, each with high/low limits for automatic selection and display of these Graphics. As an example, a graphic representation of a thermometer would rise and fall. In response to either the room temperature or its

deviation from the controlling setpoint. Analog output objects, when selected with the mouse, shall be displayed as a prompted dialog (text only) box. Selection for display type shall be individual for each object. Analog object values may be changed by selecting either the “increase” or “decrease” arrow in the analog object spinner box without using the keypad. Pressing the button on the right side of the analog object spinner box allows direct entry of an analog value and accesses various menus where the analog value may be used, such as trendlogs. Analog objects may also be assigned to an area of a system graphic, where the color of the defined area changes based on the analog object’s value. For example, an area of a Floor-plan graphic served by a single control zone would change color with respect to the Temperature of the zone or its deviation from setpoint. All editing and area assignment Shall be created or modified online using simple icon tools.

- v. A customized menu label (push-button) shall be used for display selection. Menu items on a display shall allow penetration to lower level displays or additional menus. Dynamic Point information and menu label push buttons may be mixed on the same display to allow sub-displays to exist for each item. Each display may be protected from viewing unless operator has appropriate security level. A security level may be assigned to each Display and system object. The menu label shall not appear on the graphic if the operator does not have the appropriate security level.
- vi. A mouse shall be used to move the pointer arrow to the desired item for selection of new display or to allow the operator to make changes to object data.

b. Password Protection

1. Provide security system that prevents unauthorized use unless operator is logged on. Access shall be limited to operator’s assigned functions when user is logged on. This Includes displays as outlined above.
2. Each operator’s terminal shall provide security for 200 users minimum. Each user shall have an individual User ID, User Name and Password. Entries are alphanumeric Characters only and are case sensitive (except for User ID). User ID shall be 0–8 Characters, User Name shall be 0–29 characters, and Password shall be 4–8 characters Long. Each system user shall be allowed individual assignment of only those control Functions and menu items to which that user requires access. All passwords, user names and access assignments shall be adjustable online at the operator’s terminal. Each user

shall also have a set security level, which defines access to displays and individual objects the user may control. System shall include min 6 separate and distinct security levels for assignment to users.

3. System shall include an Auto Logout Feature that shall automatically logout user when there has been no keyboard or mouse activity for a set period of time. Time period shall be adjustable by system administrator. Auto Logout may be enabled and disabled by System administrator. Operator terminal shall display message on screen that user is Logged out after Auto Logout occurs.

c. Operator Activity Log

1. Operator Activity Log shall be included with system that tracks all operator changes and activities. System shall track what is changed in the system, which performed this change, date and time of system activity and value of the change before and after operator Activity. Operator shall be able to display all activity, sort the changes by user and also by operation.

2. Log shall be gathered and archived to hard drive on operator workstation as needed. Operator shall be able to export data for display and sorting in a spreadsheet.

3. Any displayed data, that is changeable by the operator, may be selected using the right Mouse button and the operator activity log shall then be selectable on the screen. Selection of the operator activity log using this method shall show all operator changes of just that displayed data.

d. Scheduling

1. Operator's workstation shall show all information in easy-to-read daily format including calendar of this month and next. All schedules shall show actual ON/OFF times for day based on scheduling priority. Priority for scheduling shall be events, holidays and daily with events being the highest.

2. Holiday and special event schedules shall display data in calendar format. Operator shall be able to schedule holidays and special events directly from these calendars.

3. Operator shall be able to change all information for a given weekly or exception schedule if logged on with the appropriate security access.

4. System shall include a Schedule Wizard for set up of schedules. Wizard shall walk user through all steps necessary for schedule generation. Wizard shall have its own pull-down selection for startup or may be started by right clicking on value displayed on graphic and then selecting Schedule.

e. Alarm Indication and Handling

1. Operator's workstation shall provide audible, visual, and printed means of alarm Indication. The alarm dialog box shall always become the top dialog box regardless of the Application(s), currently running. Printout of alarms shall be sent to the assigned terminal and port.

2. System shall provide log of alarm messages. Alarm log shall be archived to the hard disk of the system operator's terminal. Each entry shall include a description of the event initiating object generating the alarm. Description shall be an alarm message of at least 256 characters in length. Entry shall include time and date of alarm occurrence, time and date of object state return to normal, time and date of alarm acknowledgment and Identification of operator acknowledging alarm .

3. Alarm messages shall be in user-definable text (English or other specified language) and shall be entered either at the operator's terminal or via remote communication through SCADA.

4. System shall include an Alarm Wizard for set up of alarms. Wizard shall walk user through all steps necessary for alarm generation. Wizard shall have its own pull-down Selection for startup or may be started by right clicking on value displayed on graphic and then selecting alarm setup.

f. Trend log Information

1. System server shall periodically gather historically recorded data stored in the building Controllers and archive the information Archived files shall be appended with new sample Data, allowing samples to be accumulated. Systems that write over archived data shall not be allowed, unless limited file size is specified. Samples may be viewed at the operator's Workstation. Operator shall be able to scroll through all trended data. All trendlog Information shall be displayed in standard engineering units.

2. Software shall be included that is capable of graphing the trend logged object data. Software shall be capable of creating two-axis (x, y) graphs that displays up to eight object types at the same time in different colors. Graphs shall show object values relative to Time.
3. Operator shall be able to change trend log setup information. This includes the Information to be logged as well as the interval at which it is to be logged. All input, Output, and value object types in the system may be logged. All operations shall be Password protected. Setup and viewing may be accessed directly from any and all Graphics on which object is displayed.
4. System shall include a trend Wizard for setup of logs. Wizard shall walk user through all necessary steps. Wizard shall have its own pull-down selection for startup, or may be Started by right clicking on value displayed on graphic, and then selecting Trendlogs from The displayed menu.

g. Field Engineering Tools

1. Operator's workstation software shall include field-engineering tools for programming all controllers supplied. All controllers shall be programmed using graphical tools that allow the user to connect function blocks on screen that provide sequencing of all control logic. Function blocks shall be represented by graphical displays that are easily identified and distinct from other types of blocks.
2. User shall be able to pick graphical function block from menu and place on screen. Provide zoom in and zoom out capabilities. Function blocks shall be downloaded to Controller without any reentry of data.
3. Programming tools shall include a real time operation mode. Function blocks shall Display real time data and be animated to show status of data inputs and outputs when in Real time operation. Animation shall show change of status on logic devices and Countdown of timer devices in graphical format.
4. Field engineering tools shall also include a database manager of applications that include logic files for controllers and associated graphics. Operator shall be able to select unit type, input/output configuration and other items that define unit to be controlled.

5. Field engineering tool shall include Device Manager for automatic detection of devices Connected anywhere on the bacnet network by scanning of the entire network. This Function shall display device instance, network identification, model number and Description of connected devices. It shall record and display software file loaded into each controller. A copy of each file shall be stored on the computers hard drive. If needed, this file shall be downloaded to the appropriate controller by selection using the Mouse.

6. System shall include backup/ restore function that will back up entire system to selected Medium and then restore system from that media.

Workstation Hardware

1. Provide operator's workstation(s) at location(s) noted on the plans.
2. Workstation/Server Computer Minimum Requirements
 - a. Pentium IV, 3 Ghz or better
 - b. 2 GB RAM or better
 - c. 120 GB hard disk or better
 - d. High-performance graphics adapter
 - e. Ethernet 10/100 mbps network interface card
 - f. Keyboard, monitor, mouse, 3.5-inch disk drive, and CD-ROM
 - g. Windows 2000/XP Professional
 - h. Modem, 56Kb Minimum
 - i. Color Printer (Inkjet, Color Dye or Laser)

Software

At the conclusion of project, DCO shall leave with owner a CD ROM that includes The complete software operation system and project graphics, setpoints, system parameters, etc. This backup shall allow the owner to completely restore the system in case of a computer malfunction.

II. CONTROLLER

General Technical Features

1. All communication with operator workstation and all application controllers shall be via bacnet. Building controller should have in built bacnet IP Router and bacnet MSTP Router Controller shall route bacnet messages between the high-speed LAN (Ethernet

10/ 100mhz), master slave token passing (MS/TP) lans/ CHANNEL, a point-to-point (PTP – RS-232) connection and modem.

- a. Each MS/TP LAN must be software configurable from 9.6 to 76.8Kbps.
- b. The RJ-45 Ethernet connections must accept either 10Base-T or 100Base-TX Bacnet over twisted pair cable (UTP).
- c. The direct access port must be a female DB-9 connector supporting bacnet Temporary PTP connection of a portable bacnet operator terminal at 9.6 to 115.2 Kbps over RS-232 null modem cable.

Should have in built bacnet IP Router and bacnet MSTP Router

2. Building controller shall be capable of providing global control strategies for the system based on information from any objects in the system regardless if the object is directly monitored by the controller or by another controller. The program that implements these strategies shall be completely flexible and user definable. Any systems utilizing factory pre-programmed global strategies that cannot be modified by field personnel on-site or downloaded via remote communications are not acceptable. Changing global strategies via firmware changes is also unacceptable.

3. Programming shall be object-oriented using control function blocks, supporting DDC Functions. All flowcharts shall be generated and automatically downloaded to controller. Programming tool shall be resident on workstation and the same tool used for all controllers.

4. Provide means to graphically view inputs and outputs to each program block in real-time as program is executing. This function may be performed via the operator's workstation.

5. Building controller shall provide battery-backed real-time (hardware) clock functions.

6. Controller shall have a memory needed to ensure high performance and data reliability. Battery shall retain static RAM memory and real-time clock functions for a minimum of years (cumulative).

7. Global control algorithms and automated control functions should execute via 32-bit Processor.

8. Should support minimum 1500 pseudo objects and should support 90 unitary controllers on bacnet MSTP network.
9. Should support 64 programming loops
10. Should support 100 time schedules
11. Should support BIBB functionality
12. 32 MB internal RAM for data storage
13. 32 MB Flash memory for data storage
14. 256 Kb RAM for application data storage
15. The controller must be capable of operation over a temperature range of 0 to 50°C
16. The controller must be capable of operation over a humidity range of 5 to 93% RH, non-condensing

III. Bacnet Conformance

1. Building Controller shall as a minimum support Point-to-Point (PTP), MS/TP and Ethernet bacnet LAN types. It shall communicate directly via these bacnet lans as a Native bacnet device and shall support simultaneous routing functions between all Supported LAN types. Global controller shall be a bacnet conformance class 3 device And support all bacnet services necessary to provide the following bacnet functional Groups:
 - A. Clock Functional Group
 - B. Files Functional Group
 - C. Reinitialize Functional Group
 - D. Device Communications Functional Group
 - E. Event Initiation Functional Group
2. Bacnet Functional Groups as mentioned shall comply with bacnet standard for complete list of the services described. All proprietary services, if used in the system,

Shall be thoroughly documented and provided as part of the submittal data. All necessary Tools shall be supplied for working with proprietary information.

3. Standard bacnet object types supported shall include as a minimum: Analog Value, Binary Value, Calendar, Device, File, Group, Notification Class, Program and Schedule Object types. All proprietary object types, if used in the system, shall be thoroughly Documented and provided as part of the submittal data. All necessary tools shall be supplied for working with proprietary information.

4. The Building Controller shall comply with Annex J of the bacnet specification for IP Connections. This device shall use Ethernet to connect to the IP internetwork, while using the same Ethernet LAN for non-IP communications to other bacnet devices on the LAN. Must support interoperability on wide area networks (wans) and function as a bacnet Broadcast Management Device (BBMD).

a. Schedules

Each building controller shall support a minimum of (100) bacnet Schedule Objects and 100 bacnet Calendar Objects.

Logging Capabilities

1. Each building controller shall have min 32MB RAM for data backup. Any object in the system (real or calculated) may be logged. Sample time interval shall be adjustable at the operator's workstation.
2. Logs may be viewed either on-site or off-site via remote communication (at SCADA).
3. Building controller shall periodically upload trended data to networked operator's Workstation for long term archiving if desired.

Alarm Generation

1. Alarms may be generated within the system for any object change of value or state either real or calculated. This includes things such as analog object value changes, binary object state changes, and various controller communication failures.
2. Each alarm may be dialed out as noted in paragraph 2 above.
3. Alarm log shall be provided for alarm viewing. Log may be viewed on-site at the Operator's terminal or off-site via remote communications.
4. Controller must be able to handle up to 300 alarm setups stored as bacnet event Enrollment objects – system destination and actions individually configurable.

IV. CENTRAL PLANT AND AIR HANDLER APPLICATION CONTROLLERS

Provide one or more native bacnet application controllers for each air handler and provide native bacnet application controllers as needed for central plant control that adequately cover all objects listed in object list. All controllers shall interface to building controller via MS/TP LAN using bacnet protocol. No gateways shall be used.

Controllers shall include input, output and self-contained logic program as needed for Complete control of units. Controllers shall be fully programmable using graphical Programming blocks. Programming tool shall be resident on operator workstation and be the same tool as used for the building controller. No auxiliary or non-bacnet controllers shall be used. In addition to their standalone capabilities, they shall also provide the ability networked in a peer-to-peer, bacnet MS/TP field network to other ddc's, and vavs DDC, or as part of a complete facilities management system which integrates multiple field networks. These controllers may be used to optimize the energy consumption by implementing various control strategies such as temperature setup/setback etc.

Bacnet Conformance

1. Application controllers shall as a minimum support MS/TP bacnet LAN types. They shall communicate directly via this bacnet LAN at 9.6, 19.2, 38.4 and 76.8 Kbps, as Native bacnet devices. Application controllers shall be of bacnet conformance class 3 and support all bacnet services necessary to provide the following bacnet functional Groups:

- A. Files Functional Group
- B. Reinitialize Functional Group
- C. Device Communications Functional Group

2. Bacnet Functional Groups as mentioned shall comply with bacnet standard for complete list of the services described. All proprietary services, if used in the system, Shall be thoroughly documented and provided as part of the submittal data. All necessary Tools shall be supplied for working with proprietary information.

3. Standard bacnet object types supported shall include as a minimum—Analog Input, Analog Output, Analog Value, Binary Input, Binary Output, Binary Value, Device, File, and Program object types. All proprietary object types, if used in the system, shall be thoroughly documented and provided as part of the submittal data. All necessary tools shall be supplied for working with proprietary information.

4. Application controllers shall include universal inputs with 12-bit resolution that accept 3K, 10K & 20K thermistors , 0–10V DC , 0–5 V DC, 0-2 V DC , 4–20 ma and dry contact signals. Any Input on a controller may be either analog or digital with a minimum support for 15 Hz Frequency. Controller shall include binary and analog outputs on board. Analog outputs shall be switch selectable as either 0–10V DC or 0–20ma. All Outputs to be Universal Outputs with 8 bit resolution - software selectable for analog or digital with standard and custom ranges. Software shall include scaling features for analog outputs. Application controller shall include 24VDC voltage supply for use as power supply to external sensors.

5. All program sequences shall be stored on board application controller in EEPROM. No Batteries shall be needed to retain logic program. All program sequences shall be executed by controller 10 times per second and capable of min 64 PID loops for control of multiple devices. All calculations shall be completed using floating-point math and system shall support display of all information in floating-point nomenclature at operator's terminal. Programming of application controller shall be completely modifiable in the field

over installed bacnet LANs or remotely via modem interface. Operator shall program logic sequences by graphically moving function blocks on screen And tying blocks together on screen. Application controller shall be programmed using Programming tools as described in operator's terminal section.

V. EXPANDABLE CENTRAL PLANT APPLICATION CONTROLLERS

General Expandable application controller shall be capable of providing control strategies for the system based on information from any or all connected inputs. The program implementing these strategies shall be completely flexible and user definable. Any systems utilizing factory pre-programmed global strategies that cannot be modified by field personnel on-site via simple download are not acceptable.

VI. VAV BOX CONTROLLERS—SINGLE DUCT(IF APPLICABLE)

Provide one native bacnet application controller for multiple VAV box that adequately covers all objects listed in object list for unit. All controllers shall interface to building controller via MS/TP LAN using bacnet protocol. No gateways shall be used.

Controllers shall include on board CFM flow sensor, inputs, outputs and programmable, self-contained logic program as needed for control of units.

Bacnet Conformance

1. Application controllers shall as a minimum support MS/TP bacnet LAN types. They shall communicate directly via this bacnet LAN at 9.6, 19.2, 38.4 and 76.8 Kbps, as a native bacnet device. Application controllers shall be of bacnet conformance class 3 and support all bacnet services necessary to provide the following bacnet functional groups:

- A. Files Functional Group
- B. Reinitialize Functional Group
- C. Device Communications Functional Group

2. Bacnet Functional Groups as mentioned shall comply with bacnet standard for complete list of the services described. All proprietary services, if used in the system, shall be thoroughly documented and provided as part of the submittal data. All necessary tools shall be supplied for working with proprietary information.

3. Standard bacnet object types supported shall include as a minimum—Analog Input, Analog Output, Analog Value, Binary Input, Binary Output, Binary Value, Device, File and Program Object Types. All proprietary object types, if used in the system, shall be

thoroughly documented and provided as part of the submittal data. All necessary tools shall be supplied for working with proprietary information.

Application controllers shall include universal inputs with 12-bit resolution that can Accept 3K and 10K thermistors, 0–5 VDC, and dry contact signals. Inputs on controller may be either analog or digital. Controller shall also include support and modifiable programming for interface to intelligent room sensor with digital display. Controller shall also include binary outputs on board. For applications using variable speed parallel fans, provide a single analog output selectable for 0-10 V or 0-20 ma control signals. Application controller shall include microprocessor driven flow sensor for use in pressure Independent control logic. All boxes shall be controlled using pressure independent Control algorithms and all flow readings shall be in CFM (LPS if metric). All program sequences shall be stored on board application controller in EEPROM. No batteries shall be needed to retain logic program. All program sequences shall be executed by controller 10 times per second and shall be capable of min 64 PID loops for Control of multiple devices. Programming of application controller shall be completely modifiable in the field over installed bacnet LANs or remotely via modem interface.

Operator shall program logic sequences by graphically moving function blocks on screen and tying blocks together on screen. Application controller shall be programmed using the same programming tool as Building Controller and as described in operator workstation section. All programming tools shall be provided as part of system.

Application controller shall include support for intelligent room sensor. Display on room Sensor shall be programmable at application controller and include an operating mode and a field service mode. All button functions and display data shall be programmable to Show specific controller data in each mode based on which button is pressed on the sensor. See sequence for specific display requirements for intelligent room sensor.

On board flow sensor shall be microprocessor driven and precalibrated at the factory.

All factory calibration data shall be stored in EEPROM. Calibration data shall be field adjustable to compensate for variations in VAV box type and installation. All calibration parameters shall be Adjustable through intelligent room sensor. Operator workstation, portable computers and Special hand-held field tools shall not be needed for field calibration.

Provide duct temperature sensor at discharge of each VAV box that is connected to controller for reporting back to operator workstation.

VII. SENSORS AND MISCELLANEOUS DEVICES

Temperature Sensors

All temperature sensors to be solid state electronic, factory-calibrated to within 0.5°F, Totally interchangeable with housing appropriate for application. Wall sensors to be installed as indicated on drawings. Mount 48 inches about finished floor. Duct sensors to be installed such that the sensing element is in the main air stream. Immersion sensors to be installed in wells provided by control DCO, but installed by mechanical DCO. Immersion wells shall be filled with thermal compound before installation of Immersion sensors. Outside air sensors shall be installed away from exhaust or relief Vents, not in an outside air intake and in a location that is in the shade most of the day.

Wall Sensor

1. Standard wall sensor shall use solid-state sensor identical to intelligent room sensor and shall be packaged in aesthetically pleasing enclosure. Sensor shall provide override function, warmer/cooler lever for set point adjustment and port for plug-in of Field Service Tool for field adjustments. Override time shall be stored in controller and be adjustable on a zone-by-zone basis.

Field Service Tool

1. Field service tool / laptop shall allow technician to view and modify all setpoints and tuning parameters stored in application controller. In addition, technician shall be able to view status of all inputs and outputs on digital readout. Each piece of data shall have a data code associated with it that is customizable.

2. Field service tool shall plug into wall sensor and provide all the functionality specified. Operator workstation shall include the capability to disable operation of the field service tool.

VIII. ELECTRONIC ACTUATORS AND VALVES

Quality Assurance for Actuators and Valves

- UL Listed Standard 873.
- NEMA 2 rated enclosures for inside mounting, provide with weather shield for outside Mounting.

Execution Details for Actuators and Valves

1. Furnish a Freeze-stat and install "Hard Wire" interlock to disconnect the mechanical spring return actuator power circuit for fail-safe operation. Use of the control signal to drive the actuators closed is not acceptable.

2. Each DDC analog output point shall have an actuator feedback signal, independent of Control signal, wired and terminated in the control panel for true position information and Troubleshooting. Or the actuator feedback signal may be wired to the DDC as an analog Input for true actuator position status. This is not applicable to terminal units' actuators.

3. VAV box damper actuation shall be Floating type or Analog (2-10vdc, 4-20ma).

4. Booster-heat valve actuation shall be Floating type or Analog (2-10vdc, 4-20ma).

5. Primary valve control shall be Analog (2-10vdc, 4-20ma).

Actuators for Damper and Control Valves ½ inch to 6 inch shall be Electric unless otherwise specified, provide actuators as follows:

1. UL Listed Standard 873 and Canadian Standards association Class 481302 shall certify Actuators.

2. NEMA 2 rated actuator enclosures are. Use additional weather shield to protect actuator when mounted outside.

3. Position indicator device shall be installed and made visible to the exposed side of the Actuator. For damper short shaft mounting, a separate indicator shall be provided to the Exposed side of the Actuator.

4. A push button gearbox release shall be provided for all non-spring actuators. Not required in case of spring return actuators.

5. Modulating actuators shall be 24Vac and consume 10VA power or less.

6. Conduit connectors are required when specified and when code requires it.

Damper Actuators:

1. Outside Air and Exhaust Air Damper Actuators shall be Mechanical Spring Return. Capacitors or other non-mechanical forms of fail-safe are not acceptable. The actuator Mounting arrangement and spring return feature shall permit normally open or normally closed positions of the damper as required.

2. Actuators shall utilize Analog control 2-10 VDC, Floating control is not Acceptable.

3. Electric damper actuators (including VAV box actuators) shall be direct shaft mounted and use a V-bolt and toothed V-clamp causing a cold weld effect for positive gripping. Single bolt or setscrew type fasteners are not acceptable.

4. One electronic actuator shall be direct shaft mounted per damper section. No connecting rods or jackshafts shall be needed. Small outside air and return air economizer dampers may be mechanically linked together if one actuator has sufficient torque to drive both and damper drive shafts are both horizontal installed.

Valve Actuators ½ inch to 6 inch

- Mechanical spring or non-spring return with manual override switch shall be provided on all actuators for pre-heat coil and actuators for AHU heating or cooling coil when units are mounted outside. See plans for fail save flow function: Normal Open or Normal Closed. Capacitors or other non-mechanical forms of fail-safe are not acceptable.
- All zone service actuators shall be non-spring return unless otherwise specified.
- The valve actuator shall be capable of providing the minimum torque required for proper valve close off for the required application.
- All control valves actuators shall have an attached 3-foot cable for easy installation to a Junction box.
- Override handle and gearbox release shall be provided for all non-spring return valve Actuators.

Control Valves ½ inch to 6 inch:

The BAS DCO shall furnish all specified motorized control valves and actuators. BAS DCO shall furnish all control wiring to actuators. The Plumbing DCO shall install all valves. Equal Percentage control characteristic shall be provided for all water coil control valves. Linear valve characteristic is acceptable for 3-way valves 2½ inches and above.

1. Characterized Control Valves shall be used for hydronic heating or cooling applications and small to medium AHU water coil applications to 100GPM.

- a. Leakage is Zero percent, Maximum differential is 30psi.

- b. Valves ½ inch through 2 inches shall be forged brass body for FCU applications and bronze body for AHU applications, NPT screw type connections.
- c. Valves ½ inch through 1-1/4 inches shall be rated for 16 bar of working pressure. Valves 1-1/2 inch and 2 inches shall be rated for PN16.
- d. The operating temperature range shall be 0° to 50° C.
- e. Stainless steel ball & stem shall be furnished on all modulating valves.
- f. Two-way and three-way valves shall have an equal percentage control port. Full
- g. Stem rotation is required for maximum flow to insure stable BTU control of the coil.
- h. Three-way valve shall be applicable for both mixing and diverting.
- i. The valves shall have an ISO type, 4-bolt flange, for mounting actuator in any
- j. Orientation parallel or perpendicular to the pipe.
- k. A non-metallic thermal isolation adapter shall separate valve flange from actuator.
- l. One fastening screw shall secure the direct coupling of the thermal isolation adapter
- m. Between the actuator and the valve. This will prevent all lateral or rotational forces
- n. From affecting the stem and it's packing O-rings.

Butterfly valves

1. Butterfly Valves

shall be sized for modulating service at 60-70 degree stem rotation. Isolation valves shall be line-size.

- a. Body is Cast Iron.
- b. Disc is Aluminum Bronze standard.
- c. Seat is EPDM Standard.
- d. Flange is ANSI 125/250.
- e. Media Temperature Range is –22F to 240F.
- f. Maximum Differential Pressure is 200 psi for 2” to 6” size.

2. Performance Verification Test

Control loops shall cause productive actuation with each movement of the actuator And actuators shall modulate at a rate which is stable and responsive. Actuator movement shall not occur before the effects of previous movement have affected the sensor.

3. Actuator Mounting for Damper and Valve arrangements

shall comply to the following:

- a. Damper Actuators: Shall not be installed in the air stream
- b. A weather shield shall be used if actuators are located outside. For Damper Actuators use clear plastic enclosure.
- c. Actuator cords or conduit shall incorporate a drip leg if condensation is possible. Water shall not be allowed to contact actuator or internal parts. Location of conduits.
- d. In temperatures dropping below dew point shall be avoided to prevent water from condensing in conduit and running into actuator.

4. Valve Sizing for Water Coil

- a. On/Off Control Valves shall be line size.
- b. Modulating Control Valve Body Size may be reduced at most two pipe sizes from the line size or not less than $\frac{1}{2}$ the pipe size. The BAS DCO shall size all water Coil control valves for the application as follows:
 - i. Booster-heat valves shall be sized not to exceed 4-9psi differential pressure. Size Valve for 50% Valve Authority. Valve design pressure drop is equal to the sum of coil drop plus the balance valve drop.
 - ii. Primary valves shall be sized not to exceed 5-15psi differential pressure. Size Valve for 50% Valve Authority. Valve design pressure drop is equal to the sum of coil drop plus the balance valve drop.
- c. Valve Mounting arrangements shall comply to the following:
 - i. Unions/ mating flanges shall be provided on all ports of two-way and three-way Valves by the plumbing DCO.
 - ii. Install three-way equal percentage Characterized Control valves in a mixing configuration with the "A" port piped to the coil.
 - iii. Install 2½ inch and above, Three-Way valves, for mixing or diverting service to the coil.

IX. ENCLOSURES

- All controllers, power supplies and relays shall be mounted in enclosures.

- Enclosures may be NEMA 1 when located in a clean, dry, indoor environment.
Indoor
- Enclosures shall be NEMA 13 or 12 when installed in other than a clean environment.
- Enclosures shall have hinged, locking doors.
- Provide laminated plastic nameplates for all enclosures in any mechanical room or Electrical room. Include location and unit served on nameplate. Laminated plastic shall
- Be 1/8 inch thick sized appropriately to make label easy to read.

EXECUTION

I. EXAMINATION

Prior to starting work, carefully inspect installed work of other trades and verify that such work is complete to the point where work of this section may properly commence.

Notify the owners' representative in writing of conditions detrimental to the proper and timely completion of the work. Do not begin work until all unsatisfactory conditions are resolved.

II. INSTALLATION (GENERAL)

Install in accordance with manufacturer's instructions.

Provide all miscellaneous devices, hardware, software, interconnections installation and programming required ensuring a complete operating system in accordance with the sequences of operation and point schedules.

III. LOCATION AND INSTALLATION OF COMPONENTS

Locate and install components for easy accessibility; in general, mount 48 inches above Floor with minimum 3'-0 inch clear access space in front of units. Obtain approval on Locations from owner's representative prior to installation.

All instruments, switches, transmitters, etc., shall be suitably wired and mounted to protect them from vibration, moisture and high or low temperatures.

Identify all equipment and panels. Provide permanently mounted tags for all panels. Provide stainless steel or brass thermowells suitable for respective application and for Installation under other sections—sized to suit pipe diameter without restricting flow.

IV. INTERLOCKING AND CONTROL WIRING

Provide all interlock and control wiring. All wiring shall be installed neatly and professionally, in accordance with Specification Division 16 and all national, state and local electrical codes. Provide wiring as required by functions as specified and as recommended by equipment Manufacturers, to serve specified control functions. Provide shielded low capacitance Wire for all communications trunks. Control wiring shall not be installed in power circuit raceways. Magnetic starters and Disconnect switches shall not be used as junction boxes. Provide auxiliary junction boxes as required. Coordinate location and arrangement of all control equipment with the Owner's representative prior to rough-in.

Provide auxiliary pilot duty relays on motor starters as required for control function. Provide power for all control components from nearest electrical control panel or as Indicated on the electrical drawings — coordinate with electrical DCO.

All control wiring in the mechanical, electrical, telephone and boiler rooms to be installed in raceways. All other wiring to be installed neatly and inconspicuously per local code requirements.

V. DDC OBJECT TYPE SUMMARY

Provide all database generation.

a. Displays

System displays shall show all analog and binary object types within the system. They shall be logically laid out for easy use by the owner. Provide outside air temperature Indication on all system displays associated with economizer cycles.

b. Run Time Totalization

At a minimum, run time totalization shall be incorporated for each monitored supply fan, return fan, exhaust fan, hot water and chilled water pumps. Warning limits for each point shall be entered for alarm and or maintenance purposes.

c. Trend log

All binary and analog object types (including zones) shall have the capability to be automatically trended.

d. Alarm

All analog inputs (High/ Low Limits) and selected binary input alarm points shall be Prioritized and routed (locally or remotely) with alarm message per owner's requirements.

e. Database Save

Provide back-up database for all stand-alone application controllers on disk.

VI. FIELD SERVICES

Prepare and start logic control system under provisions of this section. Start-up and commission systems. Allow sufficient time for start-up and commissioning Prior to placing control systems in permanent operation. Provide the capability for off-site monitoring at control DCO's local or main office. At a minimum, off-site facility shall be capable of system diagnostics. Owner shall provide phone line for this service for 1 year or as specified. Provide Owner's Representative with spare parts list. Identify equipment critical to Maintaining the integrity of the operating system.

VII. AS BUILT DOCUMENTATION REQUIRED**VIII. TRAINING**

Provide application engineer to instruct owner in operation of systems and Equipment.

Provide system operator's training to include (but not limited to) such items as the following:

- Modification of data displays, alarm and status descriptors, requesting Data, execution of commands and request of logs. Provide this training to minimum Of 3 persons.
- Provide on-site training above as required, up to 16 hours as part of this contract. Provide tuition for at least one individual for a one-week factory training class. If Applicable, costs for travel, lodging and meals will be the responsibility of the Owner.

IX. DEMONSTRATION

Provide systems demonstration under provisions of Section 15010. Demonstrate complete operating system to owner's representative. Provide certificate stating that control system has been tested and adjusted for proper Operation.

1.3.1.13 Technical Specification – Addressable Fire Alarm System

I. References

The equipment and installation shall comply with the current provisions of the following standards:

- National Electric Code, Article 760.
- National Fire Protection Association Standards:
- NFPA72 National Fire Alarm Code
- NFPA101 Life Safety Code
- Local and State Building Codes.
- Local Authorities Having Jurisdiction.
- ULC, CSFM, BSA, City of Chicago High Rise Code
- Underwriters Laboratories Inc.
- The system and all components shall be listed by Underwriters Laboratories Inc. for use fire protective signaling system under the following standards as applicable:
 - UL 864/UOJZ, APOU Control Units for Fire Protective Signaling Systems.
 - UL 268 Smoke Detectors for Fire Protective Signaling Systems.
 - UL 268A Smoke Detectors for Duct Applications.
 - UL 217 Smoke Detectors Single Station.
 - UL 521 Heat Detectors for Fire Protective Signaling Systems.
 - UL 228 Door Holders for Fire Protective Signaling Systems.
 - UL 464 Audible Signaling Appliances.
 - UL 1638 Visual Signaling Appliances.
 - UL 38 Manually Activated Signaling Boxes.
 - UL346 Water flow Indicators for Fire Protective Signaling Systems.
 - UL 1971 Standard for Signaling Devices for the Hearing Impaired
 - UL 1481 Power Supplies for Fire Protective Signaling Systems.
 - UL 1711 Amplifiers for Fire Protective Signaling Systems.
- Americans with Disabilities Act (ADA)
- International Standards Organization (ISO)
- ISO-9000
- ISO-9001
- European Union (EU)

- EMC Directive 89/ 336/ EEC - Electromagnetic Compatibility Requirements
- CENELL - Appropriate European Committee for Electro-Technology Standardization Standards.

The Fire Alarm / Life Safety System supplied under this specification shall be a microprocessor-based network system. All Control Panel Assemblies and connected Field Appliances shall be both designed and manufactured by the same company, and shall be tested and cross-listed as compatible to ensure that a fully functioning Life Safety System is designed and installed.

II. Equipment

The Life Safety System shall be a Multi-Processor Based Network System designed specifically for Fire, Audio Evacuation and Security applications. The Life Safety System shall be a UL listed under Standards 864 (Control Units for Fire-Protective Signaling Systems) under categories UOJZ and APOU.

The Life Safety System shall include all required hardware and system programming to provide a complete and operational system, capable of providing the protected premises with the following functions and operations:

- Modular systems design, with a layered application design concept, including an “Operational Layer” and a “Human Interface Layer”, to allow maximum flexibility of the system with a minimum physical size requirement.
- Audio Paging and Emergency Evacuation subsystem with fully digitized and multiplexed audio. Up to 32 minutes of pre-recorded audio is transmittable over one of 8 audio channels over a single pair of wires. The system shall not require mechanical potentiometers to make adjustment of audio levels within the system, as these devices are prone to require re-adjustment over time, and may fail under uncontrolled field conditions.
- All System operational software is to be stored in FLASH memory. Control Panel disassembly, and replacement of electronic components of any kind shall not be required in order to upgrade the operations of the installed system to conform to future application code and operating system changes.
- Up to 128 Service Groups must be definable within the system program to allow the testing of the installed system based on the physical layout of the system, not on the wiring of the field circuits connected to the Fire Alarm Control Panel.
- Advanced Windows-based software with Program Version Reporting to document any and all changes made during system start-up or system commissioning. Time

and Date Stamps of all modifications made to the program must be included to allow full retention of all previous program version data.

- System response to any alarm condition must occur within 3 seconds, regardless of the size and the complexity of the installed system.
- One amplifier shall be supplied per speaker circuit to enhance system survivability.
- Fire Fighters' Telephone System shall include a dedicated back-lit Liquid Crystal Display (LCD) to indicate in full language the Call-In Status of remote telephones. Selection of any remote telephone for two-way communications shall be accomplished with the pressing of a single switch
- System Common Control Functions shall be automatically routed to any node of the system as a function of the time of day and date.

III. The Life Safety System

Life Safety System Mechanical and Overall Feature Summary

The Life Safety System shall include the following features and shall support the following operations in each installed cabinet or node of the system:

- Up to 10 Intelligent Device loops.
- Up to 125 Intelligent Smoke Detectors and 125 Intelligent Modules per Loop.
- Up to 120 hardwired input/ output Circuits.
- Up to 342 Manual Control (Input) Switches.
- Up to 456 LED Annunciation Points
- Up to 63 Remote Display Units.
- Firefighters' Emergency Telephone Communication and Emergency Paging Operation.
- Multi-Priority, token passing, peer-to-peer network connection of up to 64 system nodes wired as Class A or Class B .
- Ground fault detection by panel, by Signature Data Circuit, and by device module.
- Ability to download all system applications programs and "firmware" from a computer through a single point in the system.
- True Distributed Intelligence, including microprocessor-based Detectors and Modules.
- AC Power Trouble Delay adjustable from 4 Hours to 10 Hours.
- Removable, Interlocked terminal blocks for the connection of the field wiring to the Fire Alarm Control Panel.
- Electronic Addressing of Field Devices.

- Advanced Power Management
- Dead Front Construction.

IV. Life Safety System Human Interface

System Common Controls and Emergency User Interface

The Fire Alarm / Life Safety System shall include an Emergency Operators' Interface Panel that shall include the following system annunciation and control functions:

System Annunciation and Control Functions:

- Hands Free Emergency Operation. The first and last highest priority event on the system shall be displayed automatically and simultaneously.
- Control Panel Internal Audible Signal shall have four programmable signal patterns, to allow for the easy differentiation between Alarm, Supervisory and Trouble and Monitor conditions within the installed system.
- 5 Discreet "System Status" LEDs:
 - Power Status LED - Green LED shall illuminate when AC power is present.
 - Test Status LED - Yellow LED shall illuminate when any portion of the system is in the test mode. A programmable timer shall cause the system to automatically exit the test mode after a period of system inactivity. This Test LED shall function in a local or in a group mode.
 - CPU Fail Status LED - Yellow LED shall illuminate when the panel controller has an internal failure.
 - Ground Fault Status LED - Yellow LED shall illuminate when ungrounded wiring connected to the cabinets' power supply has continuity to ground. This feature shall function in either a local or group mode.
 - Disable Status LED - Yellow LED shall illuminate whenever any point or zone in the installed system is manually disabled.
- **4 Discreet Common Control Switches with Associated Status LEDs:**
 - **Reset:** Depression of the Reset Switch starts the system reset operation. The associated Yellow LED shall have three flash rates during this operation to inform the user of the progress status of the reset cycle. The LED shall flash fast during the smoke detector power down sequence, then it shall flash slowly during the restart phase, and shall illuminate steadily for the restoral phase. The LED shall go out completely when the system is back to normal mode. Each phase, as well the overall reset cycle shall be programmable to perform other functions.

- **Alarm Silence:** Depression of the Alarm Silence Switch shall turn off all (audible and/ or visible) Notification Appliance Circuits. The associated yellow LED illuminates when the Alarm Silence function is active, whether by the Alarm Silence Switch, or by an integral software timer. Subsequent activation of the Alarm Silence Switch shall resound the signals. Activation of the Alarm Silence switch shall be programmable to perform other functions.
 - **Panel Silence:** Depression of the Panel Silence Switch shall turn off the systems' internal audible signal when configured as a 'local' system. The associated yellow LED illuminates when the panel silence feature is activated.
 - **Drill Switch / LED:** Depressing the DRILL switch activates the fire drill function. Yellow LED indicates that the fire drill function is active. The Drill Switch shall also be programmable to perform system functions other than the Drill Function.
- **Other Operator Control Switches:**
 - **Previous Message Switch:** Pressing the Previous Message Switch shall scroll the display to show the preceding message in the selected queue. Holding the Previous Message Switch and pressing any queue select switch moves to the top of the respective queue event list. Scrolling through event messages may be done by the operator at any time.
 - **Next Message Switch:** Pressing the Next Message Switch shall scroll the display to show the following message in the selected queue. Holding the Previous Message Switch and pressing any queue select switch moves to the bottom of the respective queue event list. Scrolling through event messages may be done by the operator at any time.
 - **More Details Switch:** Pressing the More Details Switch shall show the address and 42 character location message of the active device on display. If a zone is active, pressing the switch displays the address and message of active devices within the zone. When multiple devices are active, the "Previous/ Next" message switch may be used to scroll through the messages.

The System Main Liquid Crystal Display:

The Liquid Crystal display shall provide the means to inform the System Operator with detailed information about the off-normal status of the installed Fire Alarm / Life Safety

System. The Main Display shall automatically respond to the status of the system, and shall display that status on a 8 line by 21 character backlit alpha-numeric Graphical Liquid Crystal Display.

Automatic Functions:

The following status functions shall be annunciated by the Main Liquid Crystal Display:

When the Fire Alarm / Life Safety System is in the “Normal” Mode, the LCD displays:

- The current Date and Time.
- A Custom System Title (2 lines X 21 characters).
- A summary total of the Alarm History of the system.

With the Fire Alarm Life Safety System in the Alarm Mode, the LCD shall automatically reconfigure into four logical windows.

Systems Status Window

The LCD shall show the system time, and the number of active points and disabled points in the system in this section of the LCD Display.

Current Event Window

The LCD shall show the first active event of the highest priority in reverse text to highlight the condition to the Emergency Operator. The top line of the reversed text shall show the sequence number in which the displayed event was received, as well as its event type. The second and third lines of reversed text shall display an identification message related to the displayed event.

Last Event Window

The LCD shall show the most recent, highest priority event received by the system.

Type Status Window

The LCD shall show the total number of active events in the system, by event type. There shall be four different System Event Types that shall be displayed, “Alarm Events”, “Supervisory Events”, “Active Trouble Events”, and “Active Monitor Events”.

System Message Processing:

In order to simplify, and to clarify the System Status information that is given to the Emergency Operator, the Main LCD shall include queues for each of the System Event Types. The Main LCD shall allow the Emergency operator access to the System Status information contained within those queues by pressing an associated queue select switch. Whenever there is an unacknowledged event in any of the System Event queues, the associated Status LED shall flash. Viewing each event listed in a queue shall

acknowledge all events in that queue, and shall cause the associated LED to illuminate steady.

All messages contained in any of the System Event queues shall be accessible for review by the Emergency Operator using the "Previous/ Next" message switch. It shall be possible to route additional event information to a printer.

i. Maintenance Menu:

The Main LCD shall also allow the System Operator to access system maintenance functions through a four level password system. The authorized System Operator shall be able to access the following functions:

ii. System Status

The system shall allow the operator to determine the status of individual system components, including active points, disabled points, and active points by panel. **list additional**

iii. Enable

The system shall allow the operator to restore a disabled point (device) in the system, allowing that point (device) to operate as originally intended by the application program of the system.

Additionally, the system shall allow the operator to restore any group function, guard patrol function, Panel, system module, "software - defined zone", operator control, or time control function.

iv. Disable

The system shall allow the operator to disable any point (device) in the system, inhibiting that point (device) from operating as originally intended by the application program of the system.

Additionally, the system shall allow the operator to disable any group function, guard patrol function, Panel, system module, "software - defined zone", operator control, or time control function within the system.

v. Activate

The system shall allow the operator to manually turn on any system output point, or system function. Alternate Smoke Detector sensitivity, message routing within the system, guard patrol timing, and check-in group timings shall be modifiable with this simple command from the control panel.

vi. Restore

The system shall allow the operator to restore the primary (application program defined) operation to the Smoke Detector sensitivity and the message routing functions with this simple command from the control panel.

vii. Control Output

The system shall allow the operator to manually command and control relays and LEDs. Relays shall be able to be commanded to “Latch”, to energize as a “High Priority”, or as a “Low Priority”, to “Energize”, or to “De-Energize”.

LEDs shall be able to be commanded to “Latch”, to energize as a “High Priority”, or as a “Low Priority”, to turn “On”, to turn “Off”, to “Slow Blink”, or to “Fast Blink”.

viii. Reports

The system shall provide the operator with system reports that give detailed description of the status of certain system parameters for corrective action, or for preventative maintenance programs. The system shall provide these reports via the Main LCD, and shall be capable of being printed on any of the connected system printers.

- The system shall provide a report that gives a sensitivity listing of all detectors that have less than 75% environmental compensation remaining.
- The system shall provide a report that provides a sensitivity listing of any particular detector.
- The system shall provide a report that gives a listing of the sensitivity of all of the detectors on any given panel in the system, or any given SDC loop within any given panel.
- The system shall provide a report that gives a chronological listing of up to the last 1740 system events.
- The system shall provide a listing of all of the firmware revision listings for all of the installed network components in the system.

ix. Program

The system shall allow the authorized operator to perform all of the following system functions:

- Set the System Time
- Set the System Date
- Set (Change) the System Passwords.
- Restart the System.
- Set the Dates for the System Holiday Schedule.
- Clear the Chronological System History File.

x. Test

The system shall allow the authorized operator to perform test functions within the installed system. Test functions shall be defined by the authorized operator to be performed on a per cabinet, circuit, or service group basis.

xi. Local Control and Display Annunciators

Each panel in the installed system shall include local Control and Display Annunciators. These annunciators shall have integral membrane style, tactile push-button control switches, for the control of system functions, and LEDs with programmable (software-controlled) flash rates and slide-in labels for annunciation of system events.

- The Local Control Display Annunciators shall provide the system with individual zone and / or device annunciation.
- The Local Control Display Annunciators shall provide the system with individual zone and / or device annunciation with zone and / or device disable.
- The Remote Control Display Annunciators shall provide the system with individual alarm and trouble annunciation per zone and / or device with zone and / or device disable.
- The Local Control and Display Annunciators shall provide the system with groups of three switches that have software controlled interlock to allow only one of the switches to be active at any time. The switch triads shall be used for all of the fan and damper controls in the protected premises.

xii. NetWork Repeater Panel:

Each network repeater panel in the network must have the replica of main fire alarm panel.

Remote System Point Annunciators

Each remote panel in the installed system shall include remote Control and Display Annunciators. These annunciators shall have integral membrane style, tactile push-button control switches for the control of system functions, and LEDs with programmable (software-controlled) flash rates and slide-in labels for annunciation of system events.

- The Remote Control Display Annunciators shall provide the system with individual zone and / or device annunciation.
- The Remote Control Display Annunciators shall provide the system with individual zone and / or device annunciation with zone and / or device disable.
- The Remote Control Display Annunciators shall provide the system with individual alarm and trouble annunciation per zone and / or device with zone and / or device disable.

- The Remote Control Display Annunciators shall provide the system with groups of three switches that have software controlled interlock to allow only one of the switches to be active at any time. The switch triads shall be used for all of the manual zone/ floor paging operations in the protected premises.
- The Remote Control and Display Annunciators shall be provided to provide the system with groups of three switches that have software controlled interlock to allow only one of the switches to be active at any time. The switch triads shall be used for all of the fan and damper controls in the protected premises.

xiii. System Printers

The event and status printer shall be a 9 pin, impact, dot-matrix printer with a minimum print speed of 200 characters per second at 10 characters per inch. Printer parameters shall be set up with a menu drive program in the printer. The serial cable connecting the Fire Alarm Control Panel to the Printer shall be supervised. The serial printer shall support short haul modems or Fiber-Optics modules. The printers shall list the time, date, type, and user defined message for each event printed. It shall be possible to support multiple printers per CPU. It shall be possible to define which event types are sent to the printer(s) including alarm, supervisory, trouble, monitor, and service groups.

Life Safety System Operations Interface:

xiv. SDC Card

The Signature Device Card (SDC) shall be the interface between the Fire Alarm Control Panel and the Detectors and Modules.

The communications format between the SDC and the all Devices shall be 100% digital. Communications to devices must incorporate BROADCAST POLLING and DIRECT ADDRESS SEARCH to ensure the fastest reporting of off-normal conditions to the system human interface layer.

It shall be possible to wire the SDC as Class A (Style 6 or Style 7) or Class B (Style 4) without twisted or shielded wire. It must be possible to wire branch circuits (T-Taps) from Class B Circuits.

The associated controller through the SDC shall provide the ability to set the sensitivity and alarm verification of each of the individual intelligent detectors on the circuit. It shall be possible to automatically set the sensitivity of individual intelligent detectors during day and night periods.

It shall be possible for the SDC to address all intelligent devices connected to it without having to set switches at the individual devices.

It shall be possible to obtain a mapping report of all devices connected to the circuit for confirmation of "as-built" wiring. The map shall show physical wiring of T-Taps, device types, and the panel addresses of devices connected to the circuit. The SDC shall be capable of reporting unexpected additional device addresses and changes to the wiring in the data circuit. A specific trouble shall be reported for any off-normal non-alarm condition.

The SDC shall be able to report the following information on a per intelligent device basis:

- Device Serial Number
- Device Address
- Device Type
- Current Detector Sensitivity Values and the Extent of Environmental Compensation.
- Any of 32 possible trouble codes to specifically diagnose faults.

Should a Signature Driver Controller CPU fail to communicate, the Signature circuit shall go into the stand alone mode. The circuit shall be capable of producing a loop alarm if an alarm type device becomes active during stand alone mode.

xv. Hard Wired NAC Circuits

- Provide where indicated on the plans supervised hard wired Notification Appliance Circuits (NAC) for the control of 24Vdc Signaling Appliances. The NAC shall be Class B (Style 4), and shall control up to 3.5 amps of power to the circuit.

- Provide where indicated on the plans supervised hard wired Notification Appliance Circuits (NAC) for the control of 70.7Vrms Audio Signaling Appliances. The NAC shall be Class B (Style 4), and shall control up to 35 Watts of power to the circuit.
- Provide where indicated on the plans supervised hard wired Notification Appliance Circuits (NAC) for the control of 25Vrms Audio Signaling Appliances. The NAC shall be Class B (Style 4), and shall control up to 50 Watts of power to the circuit.
- Panel NACs shall be power limited to 3.5A at 24Vdc and 4.1A at 20.4Vdc to support higher current demand by visible appliances at lower battery voltages.
- Hard Wired (2-Wire) Smoke Detector Circuits
- Provide where indicated on the plans supervised hard wired two wire initiating device circuits capable of supporting up to 20 smoke detectors. It should be possible for alarm verification with programmable verification times within UL guidelines.

Hard Wired Initiating Device Circuits

Provide where indicated on the plans supervised hard wired initiating device circuits. It should be possible for alarm, supervisory, or monitor operation.

Life Safety System Programmable Operations:

System Message Processing and Display Operations:

The Fire Alarm / Life Safety System shall allow Network Routing to be configured to any or all nodes (cabinets) in the network.

All of the system Printer ports can be configured to display any or all of the following functions:

- Alarm
- Supervisory
- Trouble
- Monitor
- Service Group

Each LCD Display on each node (cabinet) in the system shall be configurable to show the status of any or all of the following functions anywhere in the system:

- Alarm
 - Supervisory
 - Trouble
 - Monitor
- i. The system shall provide the capability to label each of the system points with up to 256 characters of location message. The first 42 characters shall be directed to the LCD while the entire message shall be sent to the printer.

- ii. The system shall have the capability to provide up to 128 logical Counting AND Groups. Each group shall have a programmable 'activation' number. Whenever the number of active devices in an AND Group reaches the activation number, the AND Groups' rules will execute. It shall be possible to 'overlap' AND groups by having devices appear in more than one group.
- iii. The system shall provide a means to monitor the well being of any or all of the occupants of the protected premises by means of a Check-In Group feature. The Check-In Group shall display an emergency alarm whenever any member of a check-in group fails to check-in during the programmable check-in period. Subsequent check-in activations during the check-in period or activations outside of the check-in period shall also activate an emergency response. It shall be possible to have a minimum of 128 check-in groups. All event messages for the Check-In feature shall be directable to any system monitor or printer.
- iv. The system shall have the ability to define a minimum of 64 Guard Patrols with up to 10 different tours each. For each tour it shall be possible to program a minimum-maximum time period between patrol stations. Each guard patrol can have up to 50 stations. Guard patrol can be started from the control panel or by operation of the first station in a tour. Guard patrol delinquencies occur when a guard is early to a station, late to a station and out of sequence. Delinquencies shall display at the control panel, perform programmable system responses, and may be directed to any printer.
- v. The system shall have the ability to define a minimum of 128 Matrix Groups with up to 250 points each. For each matrix, it shall be possible to define a 'radius' and an 'activation' number. The radius number defines the proximity between detector locations. When two detectors activate at or within the value of the 'radius' or whenever the number of active devices reaches the activation number the Matrix Group activates. It shall be possible to 'overlap' Matrix groups by having devices appear in more than one group.
- vi. The system shall include the ability to define an alternate set of device commands that may be used in combination with the system test command for the testing of the connected Signature Series Smoke Detectors. This function shall disable the normal alarm command for each of the members of the group, so that the testing process will not result in an activation of the building evacuation signals, auxiliary relays or central station connections.
- vii. The system shall include Time Control functions that will have the ability to control any system output or function, or initiate any system operational sequence as a function of the Month, Day of Week, Date, Hour, Minute, or Holiday.

- viii. The system shall include up to 600 software defined Logical Zone Groups that may group any input from any Signature Data Circuit, or other Initiating Device Circuit, in order to control a system output or function, or initiate any system operational sequence. A device or IDC may be a member of one Logical Zone Group. Each of these zones shall have an associated message.
- ix. The system shall provide the ability to download data from the Signature Series Detectors to a P.C. while the system is on-line and operational in the protected premises. The downloaded data may then be analyzed in a diagnostic program supplied by the system manufacturer.

Integrated Audio

- x. The Fire Alarm / Life Safety System shall incorporate a true digital integrated audio system into the network, multiplexing 8 independent audio channels over a single pair of wires. The system shall include distributed Audio Amplifiers, one for each speaker circuit, for the ultimate in system survivability.
- xi. The system shall provide a local temporal back up tone at each amplifier to allow evacuation signals to be broadcast in the protected premises in the event of a loss of data communication from the multiplexed audio riser.
- xii. A Digital Message Unit shall be provided which provides up to 32 minutes of pre-recorded emergency messaging. The message contained in the fully digital message unit shall be recordable in the field on a computer.

Audio Source Unit

The Fire Alarm / Life safety System shall be provided with a fully integrated Emergency Communications System. The Emergency Communications System shall include a paging microphone, digital message playback unit, and 8 fully digitized and multiplexed Audio Channels. Four dedicated page mode control switches shall provide the emergency operator with instantaneous one touch paging to safely control the staged evacuation of building occupants. Automatic programming shall dynamically group the most frequently targeted paging zones.

- The "All Call" switch will direct the manual page to the entire facility.
- The "Page to Evac" switch will direct the manual page to those building areas automatically receiving the Evacuation Signal.
- The "Page to Alert" switch will direct the manual page to those building areas automatically receiving the Alert Signal.

- The “All Call Minus” switch will direct the manual page to those building areas that are programmed to receive the auxiliary and general channel connections such as stairwells.

The system shall have paging control switches and LEDs to support specific zone selection as shown on the plans. The zone control / displays shall confirm amplifier selection and annunciate amplifier and amplifier circuit trouble.

The system shall automatically deliver a preannounce tone of 1000 Hz for three seconds when the emergency operator presses the microphone talk key. A ‘ready to page’ LED shall flash during the preannounce and turn steady when the system is ready for the user’s page delivery.

The system shall include a page deactivation timer that activates for 3 seconds when the emergency users release the microphone talk key.

Should the user subsequently press the microphone key during the deactivation period a page can be delivered immediately.

Should the timer complete its cycle the system shall automatically restore emergency signaling and any subsequent paging will be preceded by the pre-announce tone. A VU display shall display voice level to the emergency operator.

Components

a. Remote Booster Power Supplies - General

The power supply shall provide a central processor with a watchdog circuit. It shall provide 2 initiating circuits, 2 notification appliance circuits rated at 24 Vdc at 2.5A, form ‘C’ alarm and trouble contacts, and auxiliary power at 24Vdc at 500 mA. The power supply shall be a high efficiency switch mode type providing 4 A totals to the NACs, 500 mA of auxiliary power at 24Vdc, and an automatic battery charger capable of supporting up to 10 AH of sealed lead acid batteries. Site programming shall enable or disable the local trouble buzzer, allow the following of existing signal rates or select internally generated evacuation signal rates at continuous, 20 SPM, 120 SPM, temporal 3-3-3, or California continuous or march time independent of the existing signal rate. Indicators shall be power on, system trouble, ground fault, battery trouble, and notification appliance circuit trouble. It shall be possible to activate the BPS via dry contact or by connection to an existing NAC circuit. It shall be possible to convert the BPS circuits ICs and NACs to Class ‘A’ operation. The base panel shall provide a communication channel and operating power for expansion modules.

- Remote Booster Power Supply,
 - The remote booster power supply shall be Edwards incorporating all control electronics, relays, and necessary modules and components in a

surface or semi-flush mounted cabinet. The panel shall be supervised, site programmable, modular design with expansion modules to serve connection to existing NAC circuits. All initiating, notification, and low voltage power source circuits shall be power limited.

- The booster power supply shall be provided with battery back-up. The batteries shall be of the Sealed Maintenance Free type and provide 24hours of normal standby operation and 30minutes of normal alarm operation at the end of the standby period. The batteries shall be supervised for placement and low voltage. It shall be possible to mount the batteries remote from the panel.

b. Intelligent Detectors -- General

The System Intelligent Detectors shall be capable of full digital communications using both broadcast and polling protocol. Each detector shall be capable of performing independent fire detection algorithms. The fire detection algorithm shall measure sensor signal dimensions, time patterns and combine different fire parameters to increase reliability and distinguish real fire conditions from unwanted deceptive nuisance alarms. Signal patterns that are not typical of fires shall be eliminated by digital filters. Devices not capable of combining different fire parameters or employing digital filters shall not be acceptable.

Each detector shall have an integral microprocessor capable of making alarm decisions based on fire parameter information stored in the detector head. Distributed intelligence shall improve response time by decreasing the data flow between detector and Analog loop controller. Detectors are not capable of making independent alarm decisions shall not be acceptable. Maximum total Analog loop response time for detectors changing state shall be 0.5 seconds.

Each detector shall have a separate means of displaying communication and alarm status. A green LED shall flash to confirm communication with the Analog loop controller. A red LED shall flash to display alarm status. Both LEDs on steady shall indicate alarm-standalone mode status. Both LEDs shall be visible through a full 360 degree viewing angle.

The detector shall be capable of identifying up to 32 diagnostic codes. This information shall be available for system maintenance. The diagnostic code shall be stored at the detector.

Each smoke detector shall be capable of transmitting pre-alarm and alarm signals in addition to the normal, trouble and need cleaning information. It shall be possible to

program control panel activity to each level. Each smoke detector may be individually programmed to operate at any one of five (5) sensitivity settings.

Each detector microprocessor shall contain an environmental compensation algorithm that identifies and sets ambient "Environmental Thresholds" approximately six times an hour. The microprocessor shall continually monitor the environmental impact of temperature, humidity, other contaminants as well as detector aging. The process shall employ digital compensation to adapt the detector to both 24 hour long term and 4 hour short term environmental changes. The microprocessor shall monitor the environmental compensation value and alert the system operator when the detector approaches 80% and 100% of the allowable environmental compensation value. Differential sensing algorithms shall maintain a constant differential between selected detector sensitivity and the "learned" base line sensitivity. The base line sensitivity information shall be updated and permanently stored at the detector approximately once every hour.

The intelligent Analog device and the Analog loop controller shall provide increased reliability and inherent survivability through intelligent Analog standalone operation. The device shall automatically change to standalone conventional device operation in the event of a loop controller polling communications failure. In the Analog standalone detector mode, the Analog detector shall continue to operate using sensitivity and environmental compensation information stored in its microprocessor at the time of communications failure. The Analog loop controller shall monitor the loop and activate a loop alarm if any detector reaches its alarm sensitivity threshold.

Each device shall be capable of automatic electronic addressing and/or custom addressing without the use of DIP or rotary switches / or using extra hand held programming unit to program the individual detector or devices. Devices using DIP or rotary switches / hand held programming unit for addressing, either in the base or on the detector shall not be acceptable.

The intelligent Analog detectors shall be suitable for mounting on any detector mounting base.

i. Fixed Temperature Heat Detector,

Provide intelligent fixed temperature heat detectors. The heat detector shall have a low mass thermistor heat sensor and operate at a fixed temperature. It shall continually monitor the temperature of the air in its surroundings to minimize thermal lag to the time required to process an alarm. The integral microprocessor shall determine if an alarm condition exists and initiate an alarm based on the analysis of the data. Systems using central intelligence for alarm decisions shall not be acceptable. The heat detector shall have a nominal alarm point rating of 135oF (57oC). The heat detector shall be rated for

ceiling installation at a minimum of 70 ft (21.3m) centers and be suitable for wall mount applications.

ii. Fixed Temperature/Rate of Rise Heat Detector

Provide intelligent combination fixed temperature/rate-of-rise heat detectors. The heat detector shall have a heat sensor and operate at a fixed temperature and at a temperature rate-of-rise. It shall continually monitor the temperature of the air in its surroundings to minimize thermal lag to the time required to process an alarm. The integral microprocessor shall determine if an alarm condition exists and initiate an alarm based on the analysis of the data. Systems using central intelligence for alarm decisions shall not be acceptable. The intelligent heat detector shall have a nominal fixed temperature alarm point rating of 135oF (57oC) and a rate-of-rise alarm point of 15oF (9oC) per minute. The heat detector shall be rated for ceiling installation at a minimum of 70 ft (21.3m) centers and be suitable for wall mount applications.

iii. Ionization Smoke Detector

Provide intelligent ionization smoke detectors. The analog ionization detector shall utilize a unipolar ionization smoke sensor to sense changes in air samples from its surroundings. The integral microprocessor shall dynamically examine values from the sensor and initiate an alarm based on the analysis of data. Systems using central intelligence for alarm decisions shall not be acceptable. The detector shall continually monitor any changes in sensitivity due to the environmental affects of dirt, smoke, temperature, aging and humidity. The information shall be stored in the integral processor and transferred to the analog loop controller for retrieval using a laptop PC. The ion detector shall be rated for ceiling installation at a minimum of 30 ft (9.1m) centers and be suitable for wall mount applications. The ion smoke detector shall be rated for operation in constant air velocities from 0 to 75 ft/min. (0-0.38 m/sec) and with intermittent air gusts up to 300 ft/min. (1.52m/sec) for up to 1 hour.

The percent smoke obscuration per foot alarm set point shall be field selectable to any of five sensitivity settings ranging from 0.7% to 1.6%. The ion detector shall be suitable for operation in the following environment:

- Temperature: 32oF to 120oF (0oC to 49oC)
- Humidity: 0-93% RH, non-condensing

iv. Photoelectric Smoke Detector.

Provide intelligent photoelectric smoke detectors. The analog photoelectric detector shall utilize a light scattering type photoelectric smoke sensor to sense changes in air samples from its surroundings. The integral microprocessor shall dynamically examine values from

the sensor and initiate an alarm based on the analysis of data. Systems using central intelligence for alarm decisions shall not be acceptable. The detector shall continually monitor any changes in sensitivity due to the environmental affects of dirt, smoke, temperature, aging and humidity. The information shall be stored in the integral processor and transferred to the analog loop controller for retrieval using a laptop PC. The photo detector shall be rated for ceiling installation at a minimum of 30 ft (9.1m) centers and be suitable for wall mount applications. The photoelectric smoke detector shall be suitable for direct insertion into air ducts up to 3 ft (0.91m) high and 3 ft (0.91m) wide with air velocities up to 5,000 ft/min. (0-25.39 m/sec) without requiring specific duct detector housings or supply tubes.

The percent smoke obscuration per foot alarm set point shall be field selectable to any of five sensitivity settings ranging from 1.0% to 3.5%. The photo detector shall be suitable for operation in the following environment:

- Temperature: 32oF to 120oF (0oC to 49oC)
- Humidity: 0-93% RH, non-condensing

v. 3D Multisensor Detector

Provide intelligent 3D multisensor smoke detectors. The multisensor analog detector shall use a light scattering type photoelectric smoke sensor and a fixed temperature type heat sensor to sense changes in air samples from its surroundings. The integral microprocessor shall employ time based algorithms to dynamically examine values from both sensors simultaneously and initiate an alarm based on that data. Systems using central intelligence for alarm decisions shall not be acceptable. The detector shall continually monitor any changes in sensitivity due to the environmental affects of dirt, smoke, temperature, aging and humidity. The information shall be stored in the integral processor and transferred to the analog loop controller for retrieval using a laptop PC. Separately mounted photoelectric detectors and heat detectors in the same location are not acceptable alternatives. The 3D Multisensor detector shall be rated for ceiling installation at a minimum of 30 ft (9.1m) centers and be suitable for wall mount applications. The 3D Multisensor smoke detector shall be suitable for direct insertion into air ducts up to 3 ft (0.91m) high and 3 ft (0.91m) wide and with air velocities up to 5,000 ft/min. (0-25.39 m/sec) without requiring specific duct detector housings or supply tubes.

The percent smoke obscuration per foot alarm set point shall be field selectable to any of five sensitivity settings ranging from 1.0% to 3.5%. The fixed temperature alarm set point shall be 135oF (57oC) nominal. The 3D Multisensor detector shall be suitable for operation in the following environment:

- Humidity: 0-93% RH, non-condensing.

vi. 4D Multisensor Detector

Provide intelligent 4D multisensor smoke detectors. The multisensor analog detector shall use a light scattering type photoelectric smoke sensor, a unipolar ionization smoke sensor and an ambient temperature sensor to sense changes in air samples from its surroundings. The integral microprocessor shall employ time based algorithms to dynamically examine values from the three sensors simultaneously and initiate an alarm based on that data. The 4D Multisensor shall be capable of adapting to ambient environmental conditions. The temperature sensor shall self-adjust to the ambient temperature of the surrounding air and input an alarm when there is a change of 65oF (35oC) in ambient temperature. Systems using central intelligence for alarm decisions shall not be acceptable. The detector shall continually monitor any changes in sensitivity due to the environmental affects of dirt, smoke, temperature, age and humidity. The information shall be stored in the integral processor and transferred to the analog loop controller for retrieval using a laptop PC. Separately mounted photoelectric detectors, ionization detectors and heat detectors in the same location are not acceptable alternatives. The 4D Multisensor smoke detector shall be rated for ceiling installation at a minimum of 30 ft (9.1m) centers and suitable for wall mount applications. The 4D Multisensor shall be suitable for direct insertion into air ducts up to 3 ft (0.91m) high and 3 ft (0.91m) wide and air velocities up to 500 ft/min. (0-2.54 m/sec) without requiring specific duct detector housings or supply tubes.

The percent smoke obscuration per foot alarm set point shall be field selectable to any of five sensitivity settings ranging from 1.0% to 3.5%. The integral heat sensor shall cause an alarm when it senses a change in ambient temperature of 65oF (35oC) or reaches it fixed temperature alarm set point of 135oF (57oC) nominal. The 4D Multisensor detector shall be suitable for operation in the following environment:

- Humidity: 0-93% RH, non condensing

vii. Standard Detector Mounting Bases

Provide standard detector mounting bases suitable for mounting. The base shall, contain no electronics, support all detector types and have the following minimum requirements:

- Removal of the respective detector shall not affect communications with other detectors.
- Terminal connections shall be made on the room side of the base. Bases which must be removed to gain access to the terminals shall not be acceptable.

- The base shall be capable of supporting one Remote Alarm LED Indicator. Provide remote LED alarm indicators where shown on the plans.

viii. Relay Detector Mounting Bases

Provide relay detector mounting bases suitable for mounting. The relay base shall support all detector types and have the following minimum requirements:

- The relay shall be a bi-stable type and selectable for normally open or normally closed operation.
- The position of the contact shall be supervised.
- The relay operation shall be exercised by the detector processor upon power up.
- The relay shall automatically de-energize when a detector is removed.
- The operation of the relay base shall be controlled by its respective detector processor. Detectors operating standalone mode shall operate the relay upon changing to alarm state. Relay bases not controlled by the detector microprocessor shall not be acceptable.
- Form "C" Relay contacts shall have a minimum rating of 1 amp @ 30 Vdc and be listed for "pilot duty".
- Removal of the respective detector shall not affect communications with other detectors.
- Terminal connections shall be made on the room side of the base. Bases which must be removed to gain access to the terminals shall not be acceptable.

ix. Isolator Detector Mounting Bases

Provide isolator detector mounting bases suitable for mounting. The operation of the isolator base shall be controlled by its respective detector processor. Isolators which are not controlled by a detector processor shall not be accepted. Following a short circuit condition, each isolator/detector shall be capable of performing an internal self-test procedure to re-establish normal operation. Isolator/ detectors not capable of performing independent self tests shall not be acceptable. The isolator base shall support all Detector types and have the following minimum requirements:

- The isolator shall operate within a minimum of 23 msec. of a short circuit condition on the communication line.
- When connected in Class A configuration the Signature Loop Controller shall identify an isolated circuit condition and provide communications to all non isolated analog devices.
- Terminal connections shall be made on the room side of the base. Bases which must be removed to gain access to the terminals shall not be acceptable.

x. Detector Mounting Plate

Provide detector mounting plate assemblies to facilitate mounting a detector for direct insertion into a low velocity duct 3 ft (0.91m) high and 3 ft (0.91m) wide, ceiling plenum, or raised floor. Mounting plate shall be code gauge steel with corrosion resistant red enamel finish. The detector mounting plate shall support an intelligent analog Photoelectric Detector, or 3D Multisensor Detector, or 4D Multisensor Detector along with a standard, relay or isolator detector mounting base.

xi. Duct Detector Housing,

Provide smoke detector duct housing assemblies to facilitate mounting an intelligent analog Photoelectric Detector, or 3D Multisensor Detector, or 4D Multisensor Detector along with a standard, relay or isolator detector mounting base. Provide for variations duct air velocity between 300 and 4000 feet per minute (300 to 1000 feet per minute for ion-photo-heat detector). Protect the measuring chamber from damage and insects. Provide an air exhaust tube and an air sampling inlet tube which extends into the duct air stream up to ten feet. Provide drilling templates and gaskets to facilitate locating and mounting the housing. Provide five one gang knockouts for mounting optional Signature Series modules. Finish the housing in baked red enamel.

c. Intelligent Modules -- General

It shall be possible to address each Intelligent Signature Series module without the use of DIP or rotary switches. Devices using DIP switches for addressing shall not be acceptable. The personality of multifunction modules shall be programmable at site to suit conditions and may be changed at any time using a personality code downloaded from the Analog Loop Controller. Modules requiring EPROM, PROM, ROM changes or DIP switch and/or jumper changes shall not be acceptable. The modules shall have a minimum of 2 diagnostic LEDs mounted behind a finished cover plate. A green LED shall flash to confirm communication with the loop controller. A red LED shall flash to display alarm status. The module shall be capable of storing up to 24 diagnostic codes that can be retrieved for troubleshooting assistance. Input and output circuit wiring shall be supervised for open and ground faults. The module shall be suitable for operation in the following environment:

- Temperature: 32oF to 120oF (0oC to 49oC)
- Humidity: 0-93% RH, non-condensing

i. Single Input Module

Provide intelligent single input modules. The Single Input Module shall provide one (1) supervised Class B input circuit capable of a minimum of 4 personalities, each with a distinct operation. The module shall be suitable for mounting. The single input module shall support the following circuit types:

- a. Normally-Open Alarm Latching (Manual Stations, Heat Detectors, etc.)
- b. Normally-Open Alarm Delayed Latching (Waterflow Switches)
- c. Normally-Open Active Non-Latching (Monitor, Fans, Dampers, Doors, etc.)
- d. Normally-Open Active Latching (Supervisory, Tamper Switches)

ii. Dual Input Module

Provide intelligent dual input modules. The Dual Input Module shall provide two (2) supervised Class B input circuits each capable of a minimum of 4 personalities, each with a distinct operation. The module shall be suitable for mounting. The dual input module shall support the following circuit types:

- a. Normally-Open Alarm Latching (Manual Stations, Heat Detectors, etc.)
- b. Normally-Open Alarm Delayed Latching (Waterflow Switches)
- c. Normally-Open Active Non-Latching (Monitor, Fans, Dampers, Doors, etc.)
- d. Normally-Open Active Latching (Supervisory, Tamper Switches)

iii. Monitor Module

Provide intelligent monitor modules. The Monitor Module shall be factory set to support one (1) supervised Class B Normally-Open Active Non-Latching Monitor circuit. The monitor module shall be suitable for mounting

iv. Waterflow/Tamper Module

Provide intelligent waterflow/tamper module. The Waterflow/Tamper Module shall be factory set to support two (2) supervised Class B input circuits. Channel A shall support a Normally-Open Alarm Delayed Latching Waterflow Switch circuit. Channel B shall support a Normally-Open Active Latching Tamper Switch.

v. Single Input Signal Module

Provide intelligent single input signal modules. The Single Input (Single Riser Select) Signal Module shall provide one (1) supervised Class B output circuit capable of a minimum of 2 personalities, each with a distinct operation. When selected as a telephone power selector, the module shall be capable of generating its own "ring tone". The module shall be suitable for mounting. The single input signal module shall support the following operations:

Audible/ Visible Signal Power Selector (Polarized 24 Vdc @ 2A, 25Vrms @50w or 70 Vrms @ 35 Watts of Audio)

Telephone Power Selector with Ring Tone (Fire Fighter's Telephone)

vi. Dual Input Signal Module

Provide intelligent dual input signal modules. The Dual Input (Dual Riser Select) Signal Module shall provide a means to selectively connect one of two (2) signaling circuit power risers to one (1) supervised output circuit. The module shall be suitable for mounting. The dual input signal module shall support the following operation:

Audible/ Visible Signal Power Selector (Polarized 24 Vdc @ 2A, 25 Vrms @ 50w or 70 Vrms @ 35w of Audio)

vii. Control Relay Module

Provide intelligent control relay modules. The Control Relay Module shall provide one form "C" dry relay contact rated at 2 amps @ 24 Vdc to control external appliances or equipment shutdown. The control relay shall be rated for pilot duty and releasing systems. The position of the relay contact shall be confirmed by the system firmware. The control relay module shall be suitable for mounting.

viii. Universal Class A/B Module

Provide intelligent class A/B modules. The Universal Class A/B Module shall be capable of a minimum of fifteen (15) distinct operations. The module shall be suitable for mounting. The universal class A/B module shall support the following circuit types:

- Two (2) supervised Class B Normally-Open Alarm Latching.
- Two (2) supervised Class B Normally-Open Alarm Delayed Latching.
- Two (2) supervised Class B Normally-Open Active Non-Latching.
- Two (2) supervised Class B Normally-Open Active Latching.
- One (1) form "C" dry relay contact rated at 2 amps @ 24 Vdc.
- One (1) supervised Class A Normally-Open Alarm Latching.

- One (1) supervised Class A Normally-Open Alarm Delayed Latching.
- One (1) supervised Class A Normally-Open Active Non-Latching.
- One (1) supervised Class A Normally-Open Active Latching.
- One (1) supervised Class A 2-wire Smoke Alarm Non-Verified.
- One (1) supervised Class B 2-wire Smoke Alarm Non-Verified.
- One (1) supervised Class A 2-wire Smoke Alarm Verified
- One (1) supervised Class B 2-wire Smoke Alarm Verified
- One (1) supervised Class A Signal Circuit, 24Vdc @ 2A.
- One (1) supervised Class B Signal Circuit, 24Vdc @ 2A.

ix. Isolator Module

Provide intelligent fault isolators modules. The Isolator Module shall be capable of isolating and removing a fault from a class A data circuit while allowing the remaining data loop to continue operating. The module shall be suitable for mounting.

d. Intelligent Manual Pull Stations – General

It shall be possible to address each Signature Series fire alarm pull station without the use of DIP or rotary switches. Devices using DIP switches for addressing shall not be acceptable. The manual stations shall have a minimum of 2 diagnostic LEDs mounted on their integral, factory assembled single or two stage input module. A green LED shall flash to confirm communication with the loop controller. A red LED shall flash to display alarm status. The station shall be capable of storing up to 24 diagnostic codes that can be retrieved for troubleshooting assistance. Input circuit wiring shall be supervised for open and ground faults. The fire alarm pull station shall be suitable for operation in the following environment:

- Temperature: 32oF to 120oF (0oC to 49oC)
- Humidity: 0-93% RH, non-condensing

i. Manual Pull Station

Provide intelligent single action, single stage fire alarm stations. The fire alarm station shall be of metal construction with an internal toggle switch. Provide a locked test feature. Finish the station in red with silver "PULL IN CASE OF FIRE". The manual station shall be suitable for mounting.

ii. Double Action Manual Pull Station

Provide intelligent double action, single stage fire alarm stations. The fire alarm station shall be of lexan construction with an internal toggle switch. Provide a key locked test

feature. Finish the station in red with white "PULL IN CASE OF FIRE" lettering. The manual station shall be suitable for mounting

iii. **2-Stage (Presignal) Manual Pull Station**

Provide intelligent single action, two stage fire alarm stations. The fire alarm station shall be of metal construction with an internal toggle switch for first stage alarm and key switch for second stage alarm. Provide a locked test feature. Finish the station in red with silver "PULL IN CASE OF FIRE" lettering. The manual station shall be suitable for mounting.

e. **Notification Appliances -- General**

- All appliances shall be UL Listed for Fire Protective Service.
- All strobe appliances or combination appliances with strobes shall be UL Listed.
- All appliances shall be of the same manufacturer as the Fire Alarm Control Panel specified to assure absolute compatibility between the appliances and the control panels, and to assure that the application of the appliances is done in accordance with the single manufacturer's instructions.

. **Strobes**

The strobes shall have a red or white metal face plate. They shall provide 15cd /75 cd / 30 cd / 60 cd / 110 cd synchronized flash outputs. The strobe shall have lens markings oriented for wall or ceiling mounting. It shall be possible to replace the lens. Ceiling mounted strobes shall have lens markings with correctly oriented lettering. Removal of an installed strobe to change the lens markings shall not be acceptable.

1.3.1.14 **Access Control System**

I. **Scope**

- The scope of work shall cover supply, installation, testing and commissioning of entire access control system meeting the intends of the specifications and drawings.
- The system generally covers control of:
 - i. Normal door entry and exit with Reader and Controllers.
 - ii. Emergency exits
 - iii. Panic Hardware, Locking devices etc.,
- The scope of work shall also cover field training of owner's representatives for a period of 5 working days or as required on the operation and maintenance of the system during normal and emergency conditions and also include the Annual Maintenance as required by the client.

II. **Standards**

The systems shall be standard products of adequate field experience and CE, UL/FM listing.

III. Submittals

- The tenderer shall submit along with the tender:
 - A block diagram of the system proposed.
 - Makes of various components and their catalogues.
 - Comments on variances from the tender specifications indicating the financial implications.
- Upon award of the contract the following submittals shall be made:
 - Final block diagrams
 - Layout drawings of all floors showing runs of conduits and cables.
 - Layout of security command center (SCC)
 - Catalogues and selections of all equipment and component.
 - Samples of wiring materials, cards with the in scripts and all visible components.
 - All submittals shall be got approved before procurement.

IV. Controllers

- The Controllers shall be UL/EN certified and conform to UL, EN 55022 and EN 55024 standards. The Integrated Security Management System (ISMS) hardware shall comprise of modular components that connect over standard interfaces to one another called intelligent controllers. Each Intelligent Controller shall have database storage and processing module (DBU), and once data has been downloaded to the DBU it shall locally make access control decisions. Access granted or denied decisions (excluding card & biometric validation time) shall be made in under 0.5 seconds
- The DBU shall store firmware in non-volatile flash memory to allow for convenient updates through the head-end software application. The DBU shall store the cardholder and configuration database information in battery-backed memory so that loss of primary power will not cause the loss of the database. The DBU shall support configurations that include upto 12 doors with IN & OUT Reader Configuration, minimum 44 monitored input points and minimum 14 auxiliary output points.
- Network Communications: The Access Controllers should have an on – board Ethernet, TCP/ UDP with its monitoring client PC over the local or wide area

network. It should have an on – board and should support reading technologies as defined in the reader specifications.

- Memory Management: Controllers shall be capable of holding a card database of at least 60,000. Each controller should be capable of storing minimum of 40,000 events with date and time stamp.
- The Controller shall support minimum 32 time zones.

32 Bit Microprocessor for fast and reliable operations

Antipassback control, path control, control of the min/max number of cardholders present in an area using the peer-to-peer communication with other Control Units

Full stand-alone operation even in the event of power failure based upon external backup battery minimum upto 30 minutes.

Shared load operation for redundant configuration: a Control Unit shall be able to manage the Terminal devices assigned to another Control Unit should the latter be out of service. The two control units must share the same communication network.

A. APPLICATION SOFTWARE

(Integrated Security Management Software)

The software should match the controller to support various applications and shall have following features: -

- i. The ISMS shall start up as part of the Operating System and shall be based on Microsoft.NET technology and capable of using open industry standards.
- ii. The system shall be based on a multiple client – server architecture.
- iii. Disaster recovery: The ISMS product shall support disaster recovery solution using off-site database replication. It shall be capable of supporting options for 99.99% and 99.999% availability. The system must be capable of running a pair of similarly configured computers in a hot backup configuration where at any point in time, one is the acting Primary and the other acting as the Hot Backup. An on-line database duplication mechanism must be supported.
- iv. Report Generation: History reporting shall include the ability to review all system alarms, access control activity, and operator actions. The system shall support generation of reports detailing the system operation. The system shall allow custom reporting options by providing an interface to a commercially available 'off the shelf' reporting products. The interface shall present all database fields in a structured format, which does not require detailed knowledge of the database design and table relationships.

ODBC

The ISMS shall be capable of providing selected data in an ODBC format for the purpose of extracting data and creating custom reports.

- v. Clients: The system shall support an minimum 40 number of clients to suit growing requirements. The system shall provide the means for multiple operators to simultaneously administer the system from convenient locations connected via a LAN / WAN.
- vi. System Partitioning: The ISMS shall support an unrestricted number of partitions. The access point readers, monitor points, and auxiliary outputs shall be managed on a partition basis by simply defining which devices are to be included in a partition.
- vii. Events and Alarm Notification: The system should be capable of segregating events and alarms. Alarm management should be capable of being user defined based on priority levels and escalation. The ISMS shall be optionally configured to require operator comments when acknowledging alarms. E-mail Alarms: The ISMS shall support the ability to automatically e-mail alarm condition messages to a destination e-mail address to be defined by the user.
- viii. Graphical Site Maps: The system should have the ability to import and use graphical maps. Maps shall be linked together and the navigation should be user definable. A comprehensive graphical user interface should be custom definable using a library of images, icons and specific animations. Maps shall also have the ability to be configured to appear automatically on presentation of a new alarm, providing the operator with prompt visual indication that an alarm has occurred.
- ix. History Archive and System Back up: The system shall allow on line archiving of history logs, along with database back up of system configuration and cardholder details.
- x. Anti-Passback: The system shall support both "hard" anti-passback and "soft" anti-passback alarm reporting modes.

The system shall support at least six levels of operator security

1. Photo Identification Badges
2. It shall be possible to capture portraits and signatures for all cardholders and then create photo identification badges using these images.
3. The software shall seamlessly integrate to Fire Alarm & Buiding Management System. Hardwire integration shall not be acceptable.
4. The software shall be configured in HOT Standby redundant configuration to eliminate any single point of failure in the system

I. Reader Equipment Specification

Entry Card Readers: Card readers should be “single-package” type, combining electronics and antenna in one package, in the following configurations:

Short Range Entry Card Reader

- i. The reader should be of potted, polycarbonate material, sealed to a rating of IP54.
- ii. The reader should be UL/C 294 listed, and should be FCC and CE certified,
- iii. Should conform to ISO 14443/15693 (Read only) Standard.
- iv. Transmit Frequency: 13.56 MHz
- v. Should have a read range of 2"-3" when used with the compatible access card.
- vi. The reader should require that a card, once read, must be removed from the RF field before it will be read again, to prevent multiple reads from a single card presentation and anti-pass back errors.
- vii. The reader should have a Wiegand output port and should operate under internal control for read-only access control applications.
- viii. The reader shall compare the biometric template stored on the card and the live sample supplied by the card holder. In the case of a positive match of these samples, the reader shall communicate the successful match of the biometric sample to the access control system of the host data centre.
- ix. The reader should have separate terminal control points for the green and red LED's, and for the audio alarm.
- x. Security keys in the cards and readers should be required to match.

The reader should meet the following environmental specifications:

Readers should meet the following certifications:

1. Canada/UL 294
2. FCC Certification
3. CE Mark (Europe)

Readers should meet the following environmental specifications:

1. Operating temperature: -40 to 65 degrees C
2. Operating humidity: 5% to 95% relative humidity non-condensing.
3. Weatherized design suitable to withstand harsh environments

Finger print CUM SMART CARD reader

- Reading element : Optic (Mirror / Lens) based sensor or Capacitor based
- Verification Algorithm : 1:1
- False Acceptance Rate (FAR): 0.1%
- Users : Unlimited per reader

- Templates :2 templates per user
- Verification time : 1 – 2 Seconds
- Input : Card data from finger print reader
- Output : Same card data as in the Input in case of validation. No data in case of no validation
- Network : 32 units on one RS 485 type multi drop network with peer to peer communication or using LAN network for transferring templates enrolled in one unit to the other units on the same network.
- PC Connectivity : RS 232 communications with PC software for comprehensive setup & management utilities including taking back up of templates on a PC

II. Door Hardware

- Door contacts shall be long-life UL approved multi-read type employing a stable magnet. The contact shall be corrosion resistant and hermetically sealed for fail-proof operation in dusty and high humid areas. The type of contacts shall be suitable for the door, metal or wooden, and the application.
- The contacts shall be NO or NC as required with an appropriate gap spacing but not less than 15mm. Contacts shall not freeze or get stuck if the door is sparingly used. The contact rating shall be to suit the size of door and the power supply of the access control system. Door locks shall be electromagnetic. Lock will remain open in 'fail-safe'.
- Wiring from the door contact and door lock to the controller and/or reader shall be minimum 0.6 mm² shielded cable drawn in a concealed galvanised conduit or as per bill of materials.

III. Acceptance Testing

- i. The system shall be tested and validated for its function as an integrated security system conforming to the intents of the specifications. The following functional tests shall be carried out in the presence of the engineer-in-charge.

Card Readers	Card acceptance & entry clearance
	Card rejection
	Measure maximum distance of card reading (Proximity cards)
	Tamper switch
Doors	Door contact activation

	Door closing forces for delivering & door opening
	Time to door shut and to latch
	Panic/Fire escape hardware operation
Terminal Controller	Communication Failure mode: <ul style="list-style-type: none"> • Full mode operation • Event recording • Supervising the monitoring circuits
	Power failure mode <ul style="list-style-type: none"> • Full mode operation • Event recording • Supervising the monitoring circuits

- ii. All the network components shall be tested 100% and results recorded. Engineer-in-charge may make random verification of any of the components. All such verification shall be recorded.

IV. Mode of measurement

The mode of measurement shall follow the schedule of work.

1.3.1.15 Surveillance CCTV System

The High Resolution DSP Color Mini Dome Camera shall include, as a minimum, the following features/functions/specifications:

- i. The High Resolution DSP Color Mini Dome Camera shall incorporate a 1/3-inch Charge-coupled device (CCD), and a minimum of 530 TV lines of resolution utilizing an effective pixel count of no less than 768 (H) x 494 (V) NTSC, 752 (H) x 582 (V) PAL.
- ii. The High Resolution DSP Color Mini Dome Camera shall provide excellent color performance in extremely low light, down to 0.1 lux @ F1.2 (30IRE).
- iii. The High Resolution DSP Color Mini Dome Camera shall have an internal amplifier that applies gain to the signal from the CCD. The amplifier must operate when there is insufficient light in the scene to produce an acceptable video output level, and must only apply as much gain as is necessary. The camera shall incorporate one level of automatic gain Compensation (AGC), allowing the user to achieve the optimal balance of noise and low light performance in demanding environments.
- iv. The High Resolution DSP Color Mini Dome Camera shall support the use of Auto Iris/ Direct Drive lens connected to the camera via 4-pin molex socket located from the inside of the camera housing. The camera must provide DC power drive signal to the lens. The camera must provide power to the lens. Iris level controls are Tact Switches accessible from the front of the camera.
- v. The High Resolution DSP Color Mini Dome Camera shall support the use of Fixed lens, focal length is 3.6mm, each.
- vi. The power consumption of the High Resolution DSP Color Mini Dome Camera shall be no more than 1 watt. (12VDC power supply)
- vii. The High Resolution DSP Color Mini Dome Camera shall have a signal to noise ratio of 48 dB with the AGC off.
- viii. The High Resolution DSP color Mini Dome Camera shall incorporate auto-tracking white balance to constantly monitor the light and adjust its color. It has a color temperature range of 2,500K to 8,000 K.
- ix. To allow the image to be viewed properly on a standard monitor, the High Resolution DSP Color Mini Dome Camera's default gamma value must be 0.45.
- x. Camera should be CE/FCC certified

I. PTZ Speed Dome Camera

1. GENERAL REQUIREMENTS

- The product specified shall be a high speed domed camera system available in pendant or suspended ceiling mounted versions (select required Housing) designed for indoor and outdoor surveillance applications. The camera system consists of an integrated Super HAD color CCD camera with a ¼-inch imager and a motorized lens which can expand from 3.6mm to 126mm to make a 35X auto-iris, auto-focus zoom lens; a variable/high speed, 360° pan/tilt units; and an intelligent, integral receiver/driver with RS485/422. Camera should be CE/FCC certified.
- The camera shall have built-in multi protocol for easy interface with DVR or Matrix switcher systems. It should also support selectable cameras address at least up to 999.
- The camera shall be compatible with the Switcher/Controller variable speed keyboards.
- The camera shall be equipped with an optical zoom lens of 3.6mm to 126mm and 12x digital zoom facility. To ensure optimal zoom control, the camera shall provide a facility of variable speed panning and the panning speed should be 0.5deg to 90deg/sec and turbo speed of 360 deg/sec; for better tracking of the subject by the operator.
- The camera shall allow the storage of up to 240 preset scenes with each preset programmable for 16 character titles. Eight (8) guard tours shall be available to consecutively display each of the preset scenes for a programmed dwell time. Also a facility of storing 4 user control patterns of 240secs each in the memory.
- The camera shall Alarm inputs facility to interface with external devices etc as per the application. There should be minimum 8 alarm inputs and 2 alarm programmable outputs.
- The camera shall be offered in suspended ceiling or pendant mounted indoor or outdoor versions as required by the application. Outdoor mount should have an option of heater and blower with IP66 protection.

2. CAMERA SPECIFICATIONS

- a. Imager: ¼ inch Super HAD color CCD (PAL: 752H x 582V)
- b. Horizontal Resolution: 470 TVL
- c. Lens: 35x optical zoom with auto focus (3.6 mm to 126 mm) Digital Zoom: 12x

3. ELECTRICAL SPECIFICATIONS

- a. Power: 22~30 VAC, 24 VAC Normal,850mA, Built-in power line surge circuit
- b. Video output: 1.0Vp-p ± 0.1Vp-p, 75 ohms.

- c. Sensitivity: 1.0lx (30IRE), 0.1lx (IR Filter OFF), 0.001lx (IR Filter ON, 256 Fields), 0.0001lx (IR Filter OFF, 256 Fields)
- d. Signal to Noise Ratio: Greater than 50 dB.

4. MECHANICAL SPECIFICATIONS

- a. Weight: 1700g
- b. Pan: Turbo speed 360°/sec; 0°~90°/sec variable speed pan;
- c. Tilt: Degree 0°~90°, Speed 0°~90°/sec according to zoom ratio
- d. Pre-position speed: 380°/sec.

5. ENVIRONMENTAL SPECIFICATIONS

- a. Humidity: 0% to 90% RH non-condensing.
- b. Operating temperature: Indoor: 0°C to +50°C; Outdoor:-40°C to +50°C with housing
- c. Storage temperature: -20°C to +60°C

6. Color Monitor

Features:

- 21 inch flat square picture tube
- 450 TVL
- Convenient front panel push-button controls
- On-screen display/setup menus (OSD)
- Heavy-duty metal cabinet
- NTSC/PAL (auto-sensing)
- Video loop-through with automatic termination
- Supports two composite and one S-VHS video input (looping)
- Universal power supply
- Audio Input/Output- 2 channels
- Switchable overscan and underscan
- Available in black and cool grey cabinet colors

Specifications:

- Picture Tube: 21 inch (53 cm) flat square tube
- Resolution: Horizontal: 450 TV lines
- Video Standard: NTSC/PAL (automatically detects)
- Phosphor: P22
- Dot Pitch: In-line 0.71 mm stripe

- Defection: 90° angle

Electrical

- Power Source: 90 to 254 VAC 50 Hz or 60 Hz
- Power Consumption: 80 Watts
- Power Supply: NEMA 5-15P, UL
- AC Input Connector: IEC 320
- Scanning Frequency
- Horizontal: 15.75 KHz (NTSC); 15.625 KHz (PAL)

Digital Video Recorder

Stand Alone Digital Video Recorder

- 16 analog video input channels
- 1 channel audio recording & playback
- Recording, Playback, Back-up, Network recording, and Network playback at the same time (Pentaplex)
- Total 480/400 ips (NTSC/PAL) recording speed for recording speed
- Total 480/400 fps (NTSC/PAL) display speed
- Built-in splitter for split screen monitoring (1/4/ 9/13/16 split mode)
- Max. 4TB storage capacity (Through IEEE 1394 port for external HDD)
- Intelligent file system for managing event recording data

DVR supports 16 analog video channels. Video, Audio, and Text Event-Logs are digitized and stored on two internal hard-drives. Using a 'Proprietary Wavelet Algorithm,' average file size is 1-5KB while still maintaining clarity high enough for facial-recognition. In addition, Wavelet-compressed images are impossible to manipulate. With our proprietary Wavelet Algorithm, DVRs process analog video into crisp, clear, and court-admissible pictures that are up to 500% smaller than comparable to JPEG images. It also allows users to record and playback audio for one channel. With 'Quick Setup', DVR can be setup and begin recording in 5 minutes. It starts to record as soon as power is supplied and CCTV cameras are connected. The default settings offer qualified and efficient way without the hassle of confusing menus. Equipped with two IEEE 1394 ports (Fire-Wire), can expand its recording capacity up to 4TB easily. Windows' FAT32 formatted HDD is compatible with DVR. The data can be simply backed up by connecting the HDD to the PC to review critical images. And with one USB port, user can copy small sized images.

- ATM/ POS transaction text information recording and search with corresponding video

- 16 sensor inputs and 4 alarm outputs
- Built-in hardware motion detection (64- division comparison)
- Back-up with IEEE 1394(FiWi)
- PTZ Control (Preset support) via RS 232 or RS 485/RS422
- User-friendly 32bit True-color Graphic OSD Menu
- Dynamic IP (DHCP, Floating IP) support
- Optimized Wavelet compression: 1-5KB (Average file size with standard image quality)

Features

- Embedded Linux OS for excellent stability and reliability
- IR remote controller (User can control PTZ with remote controller)

1.3.1.16 NOVEC1230 OR INERGEN GAS BASED FIRE SUPPRESSION SYSTEM**NOVEC1230 OR INERGEN FIRE SUPPRESSION SYSTEM:**

The scope shall include, design, supply, installation, testing and commissioning of Automatic & Gas flooding, fire suppression system. The suppression system used shall be NOVEC1230 OR INERGEN gas based fire suppression system. The successful bidder shall make detailed working drawings and coordinate them with other agencies at site.

The critical area shall be divided into number of zones, whenever fire is detected or sensed in any of the zones, annunciation should be available on the FACP, and the suppression system in that particular zone shall be automatically activated. The flooding of the gas is considered in the area above false ceiling, below false ceiling and false floor. The server room and UPS room shall be protected with the gas based fire protection system.

The system design shall be based on the specifications contained herein, NFPA 2001 & in accordance with the requirements specified in the design manual of the agent. The bidder, shall confirm compliance to the above along with their bid.

The cylinder for storage of gas shall be high pressure, seamless steel gas cylinder, flat type, concave bottom as per IS 7285 complete with neck ring. Welded and non-CCE approved cylinders will not be accepted.

As per the regulations of the Chief Controller of Explosives (CCE) Nagpur, any system which has a working pressure above 19 bar (280 psi) will require the use of seamless cylinders that have been duly approved by the CCE, Nagpur.

Design calculation for the suppression system shall be done on UL listed, FM approved software. Design of the system shall be in accordance with NFPA 2001.

The scope shall include design, supply, installation, testing and commissioning of piping system & manifold required for the gas based suppression system. ASTM 106, Grade-B, Schedule-40 seamless pipes shall be used for this purpose.

Documentation

The bidder should prepare & submit along with the bid documents, the piping Isometric drawing and support the same with a hydraulic flow calculation generated by using the agent's design software. The calculations shall validate the fill density assumed by the bidder.

The bidder shall submit copies of the datasheets of the hardware used in the system. The bidder shall also submit copy of CCE approval letter for the cylinder proposed to be used. These documents shall be attached to the bid.

The bidder shall also submit calculations to evidence the qty of agent considered for the system.

The successful vendor must submit, along with the supply invoice, a certificate of authenticity, for the agent from the system engineering company duly checked and verified by Manufacturer.

The bidder should provide, as part of handling over, the as-built drawing, operation manual and maintenance manual. The as-built drawing shall exactly match the Isometric drawing submitted with the flow calculation prior to commencement of work.

1.3.1.17 Rodent Repellant System

I. Basic

The Pest Repellent System would consist of one master console & twelve satellites / transducers. The Master Console is installed in the control room and the satellites in the problem area. The successful bidder shall make detailed working drawings and coordinate them with other agencies at site.

II. Principle of Operation

The powerful high frequency sound waves (well above the 20 K Hz frequency which is the upper limit of the hearing range of human ear) generated by the satellites are within the hearing range of the many pests and cause them pain and discomfort and thereby, forcing them to abandon the protected area.

III. Features

1. Master Console

The Master Console would need a power connection and should be equipped with a 3-pin power supply cord of 2.5 metres.

2. Satellites

Each Satellite should cover an open area of 300sq. ft. when the average height of the ceiling is 10 ft. When installed in false ceiling / false flooring it should cover an approximate area of 150 sq. ft.

- Each satellite should occupy a maximum of space of 24 cu.in. And could be mounted in any angle.
- They should be mono-polar and there should be no risk of sparking
- They should be able to withstand high temperatures in the false ceilings.
- They would not need a power connection.

IV. Technical Information

1. Satellites

- Crystal DM 44T 24V MAS Germany. Visible Hexagonal, Triangle excitor center damp horizontal line exciters.
- Frequency :Peak frequency responses of the satellites should be,
 - 21.6 KHz +/- 3 KHz
 - 31.6 KHz +/- 3 KHz
 - 50.4 KHz +/- 3 KHz

- 60 KHz +/- 3 KHz

- Nature of Sound Waves

The sound waves propagated by the satellites should be linear sine waves with constantly varying frequencies.

- Operating Environment

The satellites should operate in a temperature range of – 4 Deg. C to 60 Deg. C, and can propagate sound waves in 100% humid conditions, and even when they are submerged under water.

2. Excitory Circuit

- Signal Generator should have full wave rectification, regulated 12 V DC power supply to withstand power fluctuations ranging from 170 VAC to 270 VAC.
- Amplifier should have a preamplifier stage coupled with signal generator for dual transistor amplification having a push – pull configuration.

3. Pressure

- Uniform Pressure output of 80 dB to 110 dB with 360 Deg. C transmission angle.
- Linear Propagation of mixed / variable frequencies detectable at, or about 40 ft. distance from the source (transducer / satellite)
- Spatial average intensity 83 mW per sq. cm.
- Pressure should vary from 50 dB to 110 dB (with built – in control for steady output)

4. Power Supply

Provision for 230 VAC and 24 VDC

1.3.1.18 Smoke detection System

Scope of Work

- This specification covers the requirements of design, supply of materials, installation, testing and commissioning of VESDA Smoke Detection System. The system shall include all equipment's, appliances and labour necessary to install the system, complete with highly sensitive LASER-based Smoke Detectors with aspirators connected to network of sampling pipes.
- The Bidder shall also make provision in the VESDA Smoke Detectors to trip AHU and to shut fire dampers if required in the event of fire through the relay contacts.

I. Codes and standards

The entire installation shall be installed to comply one or more of the following codes and standards :

- NFPA Standards, US
- British Standards, BS 5839 part :1

II. Approvals

- All the equipments shall be tested, approved, and/or listed by :
- LPCB (Loss Prevention Certification Board), UK
- FM (Factory Mutual), US
- UL (Underwriters Laboratories Inc.), US
- ULC (Underwriters Laboratories Canada), Canada
- Vds (Verband der Sachversicherer e.V), Germany

III. Design Requirements

- The System shall consist of a highly sensitive LASER-based smoke detector, aspirator, and filter.
- It shall have a display featuring LEDs and Reset/Isolate button. The system shall be configured by a programmer that is either integral to the system, portable or PC based.
- The system shall allow programming of: Multiple Smoke Threshold Alarm Levels. Time Delays, Faults including airflow, detector, power, filter block and network as well as an indication of the urgency of the fault. Configurable relay outputs for remote indication of alarm and fault Conditions.
- It shall consist of an air sampling pipe network to transport air to the detection system, supported by calculations from a computer-based design modeling tool.
- Optional equipment may include intelligent remote displays and/or a high level interface with the building fire alarm system and a dedicated System Management graphics package.
- Performance Requirements
 - Shall provide very early smoke detection and provide multiple output levels corresponding to Alert, Action, and Fire 1 & 2. These levels shall be programmable and shall be able to set sensitivities ranging from 0.005 – 20% obscuration / meter.
 - Shall report any fault on the unit by using configurable fault output relays or via the graphics Software.
 - Shall monitor for filter contamination.

- Shall incorporate a flow sensor in each pipe and provide staged airflow faults.
- Shall have a clean air supply to maintain Laser chamber clean all the time.

IV. Materials and Equipment's

- Both Light Scattering and Particle Counting shall be utilized in the device as follows:
The Laser detection Chamber shall be of the mass Light Scattering type and capable of detecting a wide range of smoke particle types of varying size. A particle counting method shall be employed for the purposes of preventing large particles from affecting the true smoke reading. Monitoring contamination of the filter (dust & dirt etc.) to notify automatically when maintenance is required.
- The Laser Detection Chamber shall incorporate a separate secondary clean air feed from the filter; providing clean air barriers across critical detector optics to eliminate internal detector contamination.
- The detector shall not use adaptive algorithms to adjust the sensitivity from the set during commissioning. A learning tool shall be provided to ensure the best selection of appropriate alarm thresholds during the commissioning process.

V. Detector Assembly

- The Detector, Filter, Aspirator and Relay Outputs shall be housed in a mounting box and shall be arranged in such a way that air is drawn continuously from the fire risk area by the Aspirator and a sample passed through the Dual/single Stage Filter and then to the detector.
- The detector shall be LASER-based and shall have an obscuration sensitivity range of 0.005 – 20% obscuration per meter.
- The detector shall have three/four independent field programmable smoke alarm thresholds across its sensitivity range
- The Detector shall also incorporate facilities to transmit the following faults
 - Detector
 - Airflow
 - Filter
 - System
 - Zone
 - Network
 - Power

Urgent and Minor faults. Minor faults shall be considered as servicing or maintenance signals. Urgent fault shall indicate that the unit may not be able to detect.

- The detector shall have single / four pipe inlets which must contain a flow sensor. Both Minor and Urgent flow faults shall be reported.
- The filter must be a single/two-stage disposable filter cartridge. The first stage shall be capable of filtering particles in excess of 20 microns from the air sample. The second stage shall be ultra-fine, removing more than 99% of contaminant particles of 0.3 microns or larger, to provide a clean air barrier around the detector's optics to prevent contamination and increase service life.
- The aspirator shall be a purpose-designed rotary vane air pump. It shall be capable of allowing/ supporting for a single pipe run / multiple sampling pipe runs with a transport time of less than 90 seconds.
- The Assembly must contain relays for fire alarm and fault conditions. The relays shall be software programmable (latching or non-latching). The relays must be rated at 2 A at 30V DC. Remote relays shall be offered as an option and either configured to replicate those on the detector or programmed differently.
- The Assembly shall have built-in event and smoke logging. It shall store smoke levels, alarm conditions, operator actions and faults. The date and time of each event shall be recorded. Each detector (Zone) shall be capable of storing up to minimum 1000 events.

VI. Displays on the Detector Assembly

The detector shall have a LED / LCD / Bar graph display for the multiple alarm threshold levels indicated and faults such as detector fault, airflow fault and indication for Isolate and Reset.

VII. Programmers

When required, a Programmer module may be located within the detector, a remote mounting box, or in a portable hand-held unit.

Each Programmer at a minimum shall support the following features:

- Programming of any device on the system.
- Viewing of the status of any device in the system.
- Adjustment of the alarm thresholds of a nominated detector.
- Setting of Day/night, weekend and holiday sensitivity threshold settings.
- Initiation of Auto Learn, to automatically configure the detectors alarms threshold settings to suit the current environment.
- Multi-level password control.
- To Program latching or non-latching relay operation.
- To Program energizing or de-energizing relays.

- To Program high and low flow settings for airflow supervision.
- To Program aspirator speed control.
- To Program maintenance intervals.
- Facilities for referencing with time dilution compensation.
- Testing of relays assigned to a specific zone to aid commissioning.

VIII. Network

- The devices in the smoke detection system shall be capable of communicating with each other via twisted pair RS485 cable. The network shall be able to support up to 250 devices (detectors, displays units and programmers), of which at least 100 detectors can be supported.
- The network shall be capable of being configured in a fault tolerant loop for both short circuit and open circuit. Any communication faults shall be reported unambiguously and shall be clearly attributable to an individual device or wire link in the fault messages.
- PC based configuration tools shall be available to configure and manage the network of detectors.
- Digital Communication Port shall comply with EIA RS485 Protocol.

SYSTEM MANAGER GRAPHIC SOFTWARE FOR COMPLETE MONITORING AND CONTROL OF VERY EARLY WARNING SMOKE DETECTION SYSTEM:

The software package shall centrally monitor and configure very early warning smoke detection and fire protection systems in multiple local or remote locations.

The software package shall be compatible with smoke detection and fire protection systems that are approved by global approvals bodies and meet all local codes, standards and regulations.

The software shall consist of monitoring and configuration components:

- The configuration component shall allow users to configure all detectors remotely by using a connected PC.
- The monitoring component shall allow users to monitor individual detectors, multiple detectors connected via a HLI or multiple HLIs.

1. System Description

Access and Usability

The software shall support local and remote password-based access control:

- Three local password-protected levels of software access: designer, user and administrator.
- Multiple user accounts with unique user-ID and password based access control.
- Remote password-management of remote fire networks
- The software shall have a user-friendly graphics user interface.
- The software shall support cut and paste functionality for common tasks.
- The software shall provide support for multiple languages including English
- The software shall support translations of messages from one supported language to another.
- The software shall support disk space monitoring.

2. Monitoring Functionality

The software shall have the capacity to monitor multiple connections:

- The software shall enable one or more workstations to monitor and configure multiple detector systems in multiple buildings and multiple sites.
- The software shall provide an event list that provides a single integrated view of all events (faults/troubles and alarms) across multiple sites.
- The software shall prioritize all events presented in the event list according to logical precedence rules.
- The software shall allow management of all events from the event list including acknowledgement of events and resetting of devices.
- The software shall allow colors to be assigned to different event types.
- The software shall allow printing of event lists.
- The software shall be able to provide an all-in-one monitoring solution:
- Using standard RS232 ports (or Ethernet) on existing and future monitoring and control systems, PCs using the software shall connect to and interpret status change data transmitted from the ports and provide graphic annunciation, control, history logging and reporting as specified herein.
- Network systems that cannot interface to Network systems or systems requiring the use of a “dry contact” or “voltage monitoring” interfaces to connect to Network shall not be accepted.

The software shall be able to connect to multiple remote sites via IP-based LAN or WAN using virtual serial port emulation.

The software shall communicate with one or more Network-compliant detectors via a high level interface (HLI) natively using the Network protocol without the necessity for using protocol translation or other communications equipment.

The software shall be able to monitor up to 250 devices.

The software shall be compatible with 4 alarm levels:

- Alert (Alarm Level 1) – may be used to activate a visual and audible alarm in the fire risk area.
- Action (Alarm Level 2) – may be used to activate the electrical/electronic equipment shutdown relay and activate visual and audible alarms in the Security Office or other appropriate location.
- Fire 1 (Alarm Level 3) – may be used to activate an alarm condition in the Fire Alarm Control Panel to call the Fire Brigade and activate all warning systems.
- Fire 2 (Alarm Level 4) – may be used to activate a suppression system and/or other suitable countermeasures (e.g. evacuation action or shutdown of systems).

The software shall allow importation of .wav files for event notification.

The software shall have a text-to-speech option to allow natural language annunciation of all faults and alarms:

- The text-to-speech component of the software shall use Nuance's RealSpeak speech engine.
- The text-to-speech functionality shall be available in a number of different languages.
- The software shall support sophisticated floor plan development and management functionality:
- The software shall enable floor plan drawings to be used in the software to graphically notify users where a smoke event is occurring in their monitored system.
- The software shall allow development of multiple levels of interconnected floor plans.
- The software shall allow importation of AutoCAD, jpg, bmp and other common image files
- The software shall include software to allow designers to create and manipulate CAD images for incorporation in meaningful context-sensitive multi-level floorplans
- The software shall allow for multiple device smoke trending on a single graph.
- The software shall support printing on a printer such as a line printer that supports Unicode.
- The software shall support sophisticated event log management functionality:
- Event logs from all networked detectors shall be able to be retrieved and viewed.
- Event logs for each monitored site and/or combined event logs for multiple sites.

- Event logs shall be able to be archived and sorted
- Total event integration, consolidation and archiving across multiple networks shall be provided. All system, network and device events shall be stored in an ODBC-compliant database.
- A remote notification facility shall enable the use of email (or SMS) to provide immediate and up-to-date information the system's operational status irrespective of location.
- The software shall enable presentation of unique customised corporate response procedures upon occurrence of specific events in defined parts of the facility

3. Configuration Functionality

The software shall allow configuration of all models of detectors:

- Full remote programming of all detector functions.
- Saving of detector configurations for safe storage.
- The software shall allow creation of off-line configurations for all such detectors and allow a merge and compare of off-line configuration with on-line configurations.

4. Performance Requirements

The software shall operate on either Windows 2000 Professional or Windows XP Professional.

The software shall function on the following minimum PC specifications:

- Processor – Pentium. Minimum configuration: P4 2.3Ghz 1MB cache
- RAM – 2 GB
- Hard Disk – 1 by 80 GB system Disk; 2 by 80 GB if connected to Raid Storage
- Display – Preferred: Dual Monitor AGP Card with 256 MB memory. Minimum: Single Monitor 128 MB memory.

5. Sampling Pipe

- The sampling pipe shall be smooth bore with an internal diameter between 15-25 mm. normally; pipe with an outside diameter of 25mm and internal diameter of 21mm should be used.
- The pipe material should be suitable for the environment in which it is installed, or should be the material as required by the specifying body.
- All joints in the sampling pipe must be air tight and made by using solvent cement, except at entry to the detector.

- The pipe shall be identified as VESDA Smoke Detector Pipe along its entire length at regular intervals not exceeding the manufacturer's recommendation or that of local codes and standards.
- All pipes should be supported at not less than 1.5m centres, or that of the local codes or standards.
- The far end of each trunk or branch pipe shall be fitted an end cap and drilled with a hole appropriately sized to achieve the performance as specified and as calculated by the system design.

6. Sampling Holes

- Sampling Holes of 2mm, or otherwise appropriately sized holes, shall not be separated by more than the maximum distance allowable for conventional detectors as specified in the local codes & standards. Intervals may vary according to calculations.
- Each sampling point shall be identified in accordance with Codes or Standards.
- Consideration shall be given to the manufacturer's recommendations and standards in relation to the number of Sampling Points and the distance of the Sampling Points from the ceiling and roof structure and forced ventilation systems.

7. Installation

- The DCO shall install the system in accordance with the manufacturer's recommendation.
- Where false ceilings are available, the sampling pipe shall be installed above the ceiling, and Capillary Sampling Points shall be installed on the ceiling and connected by means of a capillary tube.
- The minimum internal diameter of the Capillary tube shall be 5mm, the maximum length of the capillary tube shall be 2m unless the manufacturer in consultation with the engineer have specified otherwise.
- The Capillary tube shall terminate at a ceiling Sampling Point specifically approved by the Client. The performance characteristics of the sampling points shall be taken into account during the system design.
- Air Sampling Piping network shall be laid as per the approved pipe layout. Pipe work calculations shall be submitted with the proposed pipe layout design for approval.

8. Testing

○ Commissioning Test

- Commissioning of the entire installation shall be done in the presence of the owner and/or its representative.
- All necessary instrumentation, equipment, materials and labour shall be provided by the DCO.
- The DCO shall record all tests and system calibrations and a copy of these results shall be retained on site in the system Log Book.

○ Functional Test

- Introduce Smoke into the Detector Assembly to provide a basic functional test.
- Introduce smoke to the least favourable Sampling Point in each Sampling Pipe. Transport time is not to exceed 90 Sec's.

1.3.1.19 Water Leak Detection System

I. General

Water leak detection System shall be designed to protect the Air-conditioned premises and to alert the personnel about the leak in the AC systems. The system shall be capable of interfacing to Water leak detection sensors, condensation sensors & I/O modules.

Events should be clearly reported on LCD/LED display with full English language description of the nature of the fault in the panel. The successful bidder shall make detailed working drawings and coordinate them with other agencies at site.

Water Leak Detection systems shall be integrated with BMS.

II. Equipment

The Water leak detection system shall comprise of Tape Sensors, Water Leak detection modules, Condensation detectors, I/O modules and sounders all connected to a Control Panel.

III. Control Panel

The control panel shall be Computerized 4/8/12 zone multiplex controller with a facility to add on dialer and speech processor. The system shall be programmed, armed or disarmed through a control key pad. The control key pad shall have a 16 character LCD display for viewing various events. The code to arm or disarm the system shall be changed only by entering a master code.

The system shall have 4/8/12 zones and all the detectors shall be connected through a 2 core cable. Each area of the premises shall be divided into specific zones such that any zone shall be isolated by the user if required. The entire system shall be backed up by a maintenance free rechargeable battery to take care of system's power requirements whenever power fails. The system shall be totally tamper proof and shall activate an alarm if the control panel is opened, the sensors tampered with or if the system cables are cut even in the disarmed state. The system shall log 500 events and optionally printer shall be connected for generating reports.

The Detectors, I/O Modules, Remote Keypads and other Devices shall be connected to a system on a single 2/4/6 Core Cable Bus to avoid individual cabling of zones. The system shall have a Buffer memory of minimum 250 events and log each event with exact date and time. The controller shall have a Serial Port for connecting to a computer.

The controller shall work on 220/240V AC power supply and it shall also have a built in battery backup. The memory inside the controller shall be backed up by a lithium

battery. The controller shall work effectively over a temperature range of - 10 Deg. C to + 55 Deg. C. and 0 to 90% of Humidity.

The system shall be totally tamperproof and shall activate an alarm if the control panel is opened, the sensors tampered with or if the system cables are cut even in the disarmed state.

IV. Water Leak Detection Sensor

Water Leak Detection sensors shall be able to mount in DIN rails, inside AHU's, power distribution units or other equipment where localized leak detection is required. The detectors shall be resistant to oxidation and erosion. The detector shall have relay output for connection to the controller. LED alarm indication shall also be provided. The detectors shall operate in AC or DC supply

V. Tape Sensors

Tape sensors are used to detect water leaks usually under floors.

Tape sensors for use with water leak detectors shall be covered with plastic netting to prevent short circuits when used in metal trays or conduits, and enables the tape to be folded at right angles to allow easy routing.

VI. Sounder

The sounder shall give audible alarm when any sensor operates. It shall be complete with electronic oscillations, magnetic coil (sound coil) and accessories ready for mounting (fixing). The sound output from the Hooter should not be less than 85 decibels at the source point.

TECHNICAL SPECIFICATIONS**Controller**

No. of Zones	4/8/12
Events	500 event log
Control keypad	20 button illuminated keypad
Display	16 Character LCD on control keypad

Water leak Detector

Supply Voltage	15-30V AC/DC
Output	12A @240V AC relay contacts
Response Time	<1 Sec.
Max sensor tape length	200 Mtr.
Ambient Temperature	0° - 40°C
Relative Humidity	0 - 80% RH

Condensation Detector

Supply Voltage	24V AC/DC
Output	10A @240V AC relay contacts
Response Time	<1 Sec.
Input resistance	10 K ohm

1.3.1.20 Technical Specification – Passive Networking**Fiber optic Cable**

Cable Type	6-core, Single Mode, Armored, Loose-tube, Gel filled
Fiber Type	Single Mode, 9 / 125, 250 micron primary coated buffers
No. of cores	6
Armor	Corrugated Steel Tape Armor
Cable Construction Type	BELLCORE GR 20 / IEC 794-1
Attenuation	
@ 1310nm	0.45 db/KM
@1500nm	0.4 dB/KM
Tensile rating	1200N
Maximum Crush resistance	3000N
Operating Temperature	-40 Degree C to +60 Degree C
Cable Type	6-core, Multimode, 10G Ethernet OM3, Armored, loose-tube, Gel Filled
Fiber type	50 / 125, Laser Grade, 250 micron primary coated buffers
No. of cores	6
Cable Construction	BELLCORE GR 20 / IEC 794-1
Attenuation	
@850nm	3.5 dB / KM
@1300nm	1.5 dB / KM
Bandwidth	
@850nm	1500 MHz-KM
@1300nm	500 MHz-KM
Network Support	
10 / 100 Ethernet	2000m
155 Mbps ATM	2000m
1000 Base SX	900m
1000 Base Lx	550m without Mode Conditioning launch patch cord.
Tensile rating	1200N
Maximum Crush resistance	3000N
Operating Temperature	-40 Degree C to +60 Degree C
Armor	Corrugated Steel tape Armor

Fiber Optic Connectors

Connector Type	SC-Style, Simplex
Operating temperature	-40 Degree C to +85 Degree C
Durability & color	
MM connectors	500 cycles,
SM connectors	220 cycles,
Ferrules	Pre-radiused Ceramic Ferrules
Attenuation	Not more than 0.75 dB per mated pair

Fiber Optic Patch panels

Fiber optic patch panel	19-inch, Rack mounted Fiber optic patch panel
Height	2 U, 3.5 inches
# of fibers	6, 12, 24 or 48
# of OSP Cables for termination	Minimum 2
Grounding	2 Nos. of earthing lugs, pre-loaded
Cable Management rings	Front and rear cable management rings, pre-loaded
# of 6-port / 12-port adapter plates	4 / 4 Max.

Fiber Optic Patch Cord.

Fiber Optic Patch Cords	50/ 125 Ethernet Patch Cord
Bandwidth	
@850nm	500 MHz-KM
@1300nm	500 MHz-KM
Insertion Loss	Less than 0.5 dB

UTP Cabling System

Type	Unshielded twisted pair cabling system, TIA / EIA 568-B.1 addendum Category 6 Cabling system
Networks Support	10 / 100 Ethernet, 155 Mbps ATM, 1000 Mbps IEEE 802.3ab Ethernet, and proposed Cat 6 Gigabit Ethernet
Warranty	25-year systems warranty; Warranty to cover Bandwidth of the specified and installed cabling system, and the installation costs
Performance characteristics to be provided along with bid	Attenuation, Pair-to-pair and PS NEXT, ELFEXT and PSELFEXT, Return Loss, ACR and PS ACR for 4-connector channel

UTP Cable

Type	Unshielded Twisted Pair, Category 6, TIA / EIA 568-B.2
Material:	
Conductors	23 AWG solid bare copper or better
Insulation	Polyethylene
Jacket	Flame Retardant PVC
Pair Separator	Cross-member, fluted Spline.
Approvals	UL Listed
	ETL verified to TIA / EIA Cat 6
Operating temperature	-20 Deg. C to +60 Deg. C
Frequency tested up to	Minimum 600 MHz
Packing	Box of 305 meters
Delay Skew	45ns MAX.
Impedance	100 Ohms + / - 15 ohms, 1 to 600 MHz.

Performance characteristics to be provided along with bid	Attenuation, Pair-to-pair and PS NEXT, ELFEXT and PSELFEXT, Return Loss, ACR and PS ACR
---	---

UTP Jacks

Type	PCB based, Unshielded Twisted Pair, Category 6, TIA / EIA 568-B.2
Durability	
Modular Jack	750 mating cycles
Wire terminal	200 termination cycles
accessories	Strain relief and bend-limiting boot for cable Integrated hinged dust cover
Materials	
Housing	Polyphenylene oxide, 94V-0 rated
Wiring blocks	Polycarbonate, 94V-0 rated
Jack contacts	Phosphorous bronze, plated with 1.27micro-meter thick gold
Approvals	UL listed
Performance Characteristics to be provided with bid	Attenuation, NEXT, PS NEXT, FEXT and Return Loss

UTP Jack Panels

Type	24-port, PCB based, Unshielded Twisted Pair, Category 6, TIA / EIA 568-B.2
Ports	24
Port arrangement	Modules of 6-ports each, arranged 1port x 6.
Category	Category 6
Circuit Identification Scheme	Icons on each of 24-ports
Port Identification	9mm or 12mm Labels on each of 24-ports (to be included in supply)
Height	1 U (1.75 inches)
Durability	
Modular Jack	750 mating cycles
Wire terminal (110 block)	200 termination cycles
Accessories	Strain relief and bend limiting boot for cable
Materials	
Housing	Polyphenylene oxide, 94V-0 rated
Wiring blocks	Polycarbonate, 94V-0 rated
Jack contacts	Phosphorous bronze, plated with 1.27micro-meter thick gold
Panel	Black, powder coated steel
Approvals	UL listed
Termination Pattern	TIA / EIA 568 A and B;
Performance Characteristics to be provided along with bid	Attenuation, NEXT, PS NEXT, FEXT and Return Loss

Work station patch Cords

Type	Unshielded Twisted Pair, Category 6, TIA / EIA 568-B.2
Conductor	24 AWG 7 / 32, stranded copper
Length	7-feet
Plug Protection	Matching colored snag-less, elastomer polyolefin boot
Warranty	25-year component warranty
Category	Category 5
Plug	
Housing	Clear polycarbonate
Terminals	Phosphor Bronze, 50 micron gold plating over selected area and gold flash over remainder, over 100 micron nickel underplate
Load bar	PBT polyester
Jacket	PVC
Insulation	Flame Retardant Polyethylene

FLOOR CONCENTRATION BOX (FCB) FOR RAISED FLOOR ACCESS

The Floor Concentration Box (FCB) should be mounted under the raised floor and should provide an easy access to the consolidation box for field cables and patching cables.

The FCB should provide for clamping mechanism to the raised floor so as to get securely mounted to the access flooring without obstructing the air floor and the cooling system. The consolidation box should be used for a racking neighborhood of 3 racks as a cluster. The FCB Forms an inter-connect between work area cabling and horizontal feeder cables.

The FCB should be designed for use in 2 ft x 2 ft raised floor systems.

The consolidation box should accommodate a total of 4U (2U+2U) of standard 19-inch patch panels, Fiber Cassettes and/or cable management panels.

It should comply with NEC 300-22 (c) requirements for use in environmental air spaces.

If need arises the FCB should allow moves, adds and changes without re-terminating and re-testing cables as well as routing of the patch cables.

The FCB design should comply with TIA/EIA-568-B and ISO 11801 requirements

Installation and Acceptance Testing Specifications

Installed UTP Cabling System shall be tested with TIA / EIA 568 Level IIE / Level III hand held testers. Each installed UTP drop shall be tested as per the latest revisions of TIA / EIA 568-B Cat 6 specifications. Length, Wire Map, Attenuation, Pair-to-pair and Power Sum NEXT, ELFEXT and PS ELFEXT, Return Loss, Delay Skew, ACR and PS ACR shall be tested and results provided to SIA in soft format on a CD.

Warranty Specifications:

ITDA seeks warranty for the installed cable plant from the OEM equipment supplier. Bidder shall ensure that the OEM norms for supply, installation, testing and documentation as specified by the OEM supplier shall be adhered to, provided those are in line with TIA / EIA standards and

ITDA requirement specifications (if any). The warranty shall be provided by the OEM vendor to ITDA and shall be administered in India. The duration of the system warranty shall be for a minimum of 20 years and shall cover the system performance, application assurance and the costs of the supply of components and installation. A Sample Warranty certificate shall be provided by the bidder along with the bid.

Documentation Specifications:

The successful bidder shall after completion of the installation, submit a detailed documentation of the cable plant. The documentation shall cover, in the minimum, the following

- i. As-built diagrams of the campus Network, with building and floor wise distribution of users and connectivity
- ii. Test results for UTP and Fiber links
- iii. Consolidated BOM with manufacturer's part Nos. and quantities used.
- iv. Warranty certificate from OEM supplier

Specification of Server Racks:

1	Floor Standing Rack Server Rack - 36U / 600W / 1000D, with Heavy Duty Extruded Aluminium Frame for rigidity. Top cover with FHU provision. Top & Bottom cover with cable entry gland plates. Heavy Duty Top and Bottom frame of MS. Two pairs of 19" mounting angles with 'U' marking. Depth support channels - 3 pairs. With a Overall Weight Carrying Capacity of 500Kgs.
2	Side Panels - 36U/1000D (set of 2 per Rack)
3	Front MS Door (Fully Perforated - Mesh) U36U/600W (1 No Per Rack)
4	Rear MS Door (Fully Perforated - Mesh) 36U/600W (1 No Per Rack)
5	Fan Housing Unit 4 Fan Position (Top Mounted) (1 No Per Rack) - Monitored - Thermostat based - The Fans should switch on based on the Temperature within the rack. The Temperature setting should be Factory settable. This unit should also include - Humidity & temperature sensor
6	Fan 90CFM 230V AC, 4" dia (4 Nos Per Rack)
7	Castors with Brake (Set of 4 per Rack)
8	Keyboard Tray with BB Slides (Rotary Type) (1 No per Rack)
9	Shelf, Stationery 627mm N/W (5 Sets per Rack)
10	Power Distribution Unit - Vertically Mounted, 32AMPS with 25 Power Outputs. (20 Powerouts of IEC 320 C13 Sockets & 5 Powerouts of 5/13Amp Sockets), Electronically controlled circuits for Surge & Spike protection, LED readout for the total current being drawn from the channel, 32AMPS MCB, 3KVAC isolated input to Ground & Output to Ground (2 No per Rack). Each power distribution unit should be with built in mechanism of trip in case of short circuit.
11	1 Console (User), 4 Port Intel Based KVM Switch with in-built Cables of 1.8mtrs (Compatible with PS/2 Based Servers only) (with Speaker Support). (Palm Top Unit) (1 No Per rack)

1.3.2 Bill of Quantity – Physical Quantity Civil and Interiors

Below mentioned quantities are indicative. Bidder should quote for the complete solution and if any changes in the layout or physical site at the time of implementation which results leading to the changes in quantity and price will be born by the DCO. Bill Of Quantity – Physical Quantity Civil and Interior Works

Approx Quantity

Bidder should quote the all the scable components for which scalability is there in the component, but the line item has not been included in the additional components it will have to be added by the DCO in the BoM and cost of the line items of the component which will be required have to be included by the DCO for one unit. The cost of the components that are being presently used should be given.

The DCO will be paid additional charge against proper SLAs in addition to the QGR only if any Core Infrastructure is being added to the SDC in future. If any component is being added as part of scalability for the existing infrastructure, no additional cost will be paid to the DCO.

All the required patch cord/cards required for connecting the equipments coming into the DC will from the same OEM and will be provided by the DCO

IMPORTANT : THE ITEMS AND QUANTITY MENTIONED IN THIS BILL OF MATERIAL IS APPROXIMATE ANY MAY VARY DURING ACTUAL EXECUTION. WHILE BIDDER TO QUOTE FOR THE QUANTITY MENTIONED AGAINST EACH LINE ITEM, PAYMENTS WILL BE MADE AS PER ACTAUL MEASUREMENT. IN CASE THE BIDDER FEELS THAT SOME EXTRA ITEMS ARE REQUIRED AS PER THE SOULTION THEY PROPOSE, THEY MAY QUOTE THE SAME AS PER THE BELOW FORMAT.

SI.No (1)	Item description (2)	UOM (3)	QTY (4)	Make	Model
A	FURNITURE				
1	BMS and NOC Room, Staging & Testing room work station in. MODULAR partition with pinup board and marker board, key board trays, cpu trollys, three drawer pedestal unit with central locking, post formed table top 25mm thick, etc. complete as per SIA approved colour scheme and specifications. Sizes to as per the room space in the layout, no of people to sit, ergonomics and	Nos	28		

	aesthetics.				
2	Supply and fixing of Reception counter with curvilinear rubber wood tops, chrome plated glass mounting, perforated modesty panel, mobile storage space, sleek wire management of size 1350 x 600 mm with side storage of size 750x450x750 as per a pproved drawing, colour to match with office decor and approval by DoIT in charge.	Nos	1		
3	Floor security table of size 1500mm x 600 mm outer dimension of shape as shown in layout provision to seat 1 persons, side storage unit (size approx : 1000x450x750), provision for PC's,display etc. .	Nos	1		
4	DC Manager table of min size 1500mm x 600mm dimension with as per layout with side storage unit, back storage unit, metal powder coated key board tray, metal powder coated c.p.u trolley,with pin up board,marker board, along the full length of the table side.etc.complete as per SIA design and details.	No	1		
5	Ceramic white Board with wooden beading with ledge to hold writing and cleaning material.				
A	Size 2400 mm x 1200 mm	No	Qro		
B	Size 1800 mm x 1200 mm	Nos	Qro		
C	Size 1200 mm x 1200 mm	Nos	Qro		
7	Providing and fixing gypblock wall cladding with 8 mm thick Calcium silicate/bison board finished with 2/3/4mm thick (as per SIA specification)approved aluminium composite panel cladding to patterned layout etc. complete. The rate shall be inclusive of wastage and hardware	Sq.ft	300		

8	Providing & fixing of storage unit with 18 mm thick MDF board along with 1.5 mm approved laminate colour out side and 2 coat of enamel paint inside the storage. The rate inclusive of handle, lock, loaded hinges, tower bolt, teak wood beading and necessary				
A	Size 600mm depth x 1200mm height in Staging room.	Rft	10		
b	Size 600mm depth x 2100mm height in DCOP room	Rft	10		
	Supplying and installation of Shoe Rack suitable for 30 Pairs of shoes made of termite proof phenol bonded particle board confirming to IS specifications. The item should be either of teak / rose wood,/ cedar veneer finish to match the office décor. Triple melamine coating should be done to protect the wood veneer to make it stain proof, water proof to give an attractive, superior and long lasting finish. Fitting items like hinges, rails, handles, locks, should be provided for a perfect match as per drawings as well as approval by DoIT in charge	No	1		
B	DOORS				
1	Providing and fixing powder coated aluminium doors using 100mm X 38.1mm X 2mm sections for main door frames, 50mm X 45mm X 2mm section for door top, side and middle sections(if any), 95mm X 45mm X 2mm door bottom sections, using 8mm(unless otherwise specified) clear toughened float glass and all necessary hardwares like EDPM gaskets, heavy duty door closer etc of approved colour, 10" long rectangular S.S. handles, locking device with duplicate keys	Nos.			

	etc. complete as directed by SIA. The joints between main door frame and partition shall be filled and sealed with silicon sealant of approved make and type.				
A	size 1.5m x 2.1m equal double shutter	Nos.	1		
c	size 0.9m x 2.1m Single shutter	Nos	5		
2	Supply and Installation of Fire rated Door of minimum 45mm thickness				
a	FD1 - Size = 1200 x 2400mm (Single Leaf) Fire rated steel door (Two hours) with fire rated circular vision panel of 380mm dia, SS ball bearing butt hinges, mortise sash lock, SS lever with internal thumb turn and external key operation with heavy duty door closer and panic bar(emergency Exits only).	Nos	03		
b	FD2 - Size = 1500 x 2400mm (Unequal Double leaves) Fire rated steel door (Two hours) with fire rated circular vision panel of 380mm dia, SS ball bearing butt hinges, mortise sash lock, SS lever with internal thumb turn and external key operation with heavy duty door closer.	Nos	05		
c	PARTITIONS				
1	Providing and fixing aluminum partitons using top,center bottom aluminum 16 guage sectins with powder coating,, 8mm thk clear glass, gaskets, locking sections, etc. complete as per design and details as per the direction of SIA.	Sqft	1000		
2	Providing and fixing 4" thick gypblock partition as per design and manufacturers specification including cost of chasing for electrical conduits, fixing of doors, finished of surface to smooth to accept plastic emulsion paint, etc. complete as	Sqft	QRO		

	per the direction of SIA.Note:- (Vendor has to follow manufacturer standards while erecting this partition)				
3	Providing and fixing Fire resistant glass FIXED GLAZING of with ALUMINIUM FRAME hollow section - POWDER COATED of (100.00width ,35.00 height , 2.0 thickness (16 gauge) , 2.0 weight kg/m - APPROX) with . fire proof fillers shall be fixed and levelled properly with section. Fire resistant glass of 6mm Approved make shall be palced on section with good quality.	Sqft	600		
D	FALSE CEILING				
2	Providing and fixing Mineral fibre board - 600 x 600 x 16mm. Microlook tegular edge in true horizontal level suspended on locking 15mm grid false Ceiling system.	Sqft	qro		
3	Providing and fixing fire rated metal false ceiling with powder coated 0.4mm thk hot dipped galvanised steel tiles 595 x 595 mm with tegular edge (10mm) suitable for 25mm grid supported on suitable powder coated galvanised steel grid as per manufacturer specification. The rates shall be inclusive of cutouts for lighting, AC grills, Fire detectors, nozzles complete or equivalent. False ceiling tiles must be insulated to prevent the air leakage	Sqft	2500		
E	FALSE FLOORING				
1.a	Providing & fixing Raised access flooring(600 mm clear height): The Access Floor System shall comprise 600mm x 600mm square panels, understructure and labour, material, equipment and installation as called for in the specifications.	Sqft	1500		
	Panel: Access Floor panel of size 600x600 mm				

	<p>shall be all steel welded construction, with an enclosed bottom pan of 64 hemispherical and 36 pre-stressed reverse cones and top plain sheet which are fuse welded at 124 locations to form a panel of an overall depth of 37 mm. The inner empty core of the panel is injected with a light weight fire retardant, non combustible cementitious compound at high pressure to fill in all the crevices of the panel and ensures support of not less than 85 % of the top surface area of the panel. The panel after cleaning, degreasing, phosphating by 7 tank process is coated with 40 micron epoxy coat and is heated to achieve maximum adhesion and surface resistance. The panel is then laminated with 1.5 mm thick fire retardant floor grade antistatic laminate/pvc on a semi -automated lamination line to ensure maximum bonding to the steel surface. The edges of the laminated/PVC are protected with black PVC edge trim 5mm wide on all sides. This edge trim is mechanically locked and sealed in place to avoid detachment.</p>				
	<p>Fire Rating: The Panels shall confirm to Class O & Class 1 Fire Ratings tested as per BS 476 Part 6 & 7.</p>				
	<p>Sub Structure Pedestal Assembly Sub structure installed to support the panel shall be suitable to achieve a minimum finished floor height of 600mm from the existing floor level. Pedestal design shall confirm speedy assembly and removal for relocation and maintenance. The assembly shall provide easy adjustment of leveling and accurately align panels for a maximum 25mm up and down in the vertical</p>				

	<p>direction. Pedestals shall support an axial load of 2200kgs without permanent deflection and an ultimate load of 3500kgs.</p> <p>The Pedestal head assembly shall consist of a 75 x 75mm x 3mm embossed ribbed head projection welded to a 100mm length 17 mm dia Bright rod stud and 2 check nuts for level adjustment and arresting vertical movement. The pedestal head shall consist of an anti-vibrational PVC cap, for Panel and stringer location. The Pedestal Base assembly shall consist of 21 mm OD pipe of thickness 1.5mm projection welded to a base plate of 100 x 100 x 2mm thick with stiffening folds. The sub structure assembly shall be suitably anchored to the floor with suitable adhesive or fastener as recommended by the manufacturer. All steel components shall be zinc electro galvanized.contd...</p>				
	<p>The pedestal cap shall have an electrical conductor plate for dissipation of static electricity. The steel base plate of the sub floor with epoxy pedestal adhesive and or mechanical fixing as approved.</p>				
	<p>Stringer</p> <p>The stringer is hot dipped galvanized steel cold rolled construction specially designed with ribs embossed on 3 sides for strength, lateral stability, rolling loads and to support the panels on all four sides for alignment. The stringer to have a counter sunk holes at both ends to accommodate bolting of the same to the pedestal head assembly. The stringers shall be ribbed 25 x 32 x .8mm x 570 mm length.</p> <p>Cut-outs in Floor panels: The panels shall have</p>				

	<p>special cutouts as per the site requirement:(Nos.18)</p> <p>For electrical service outlet managers for cable entry as required to be provided with a 50mm / 75mm grommet.</p> <p>Lifting devices: Providing approved panel lifting suction devices for lifting the floor panels.(Nos.4)</p> <p>Glazed Panels: Providing and fixing of heavy duty 12mmthk. Toughened glass fixed in powder coated Al. frame of size 1'x1' Glazed Floor Panels with frame details same as above.(Nos.12)</p> <p>Note: No extra cost will be included for above items Perforated panel area shall be deducted & paid in items E.1.1. The false flooring has to meet the spec. as mentioned in the Technical specification part of the RFP</p>				
b	<p>Same as above with 600 x 600 mm floor grills made out of steel section to take a 4.5 Kn/25sqmm concentrated load(point) without outlet aluminium volume control damper. The final finish of the floor grills shall be the same in look and feel as the floor tiles with antistatic tiles. It shall be with 56% perforations of the surface area of the tile to allow smooth air draft.</p>	Nos	45		
c	<p>Supply & Fixing of Antistatic Laminate skirting matching with floor tiles with 8mm thick MDF Board upto a height of 100mm.</p>	Rft	qro		
2	<p>Providing and laying Vitrified polished tile 2'0" x 2'0" in size flooring to floor pattern of approved quality, approved colours and make, using chemical tile adhesive laid to proper level and joints pointed with tile jointing compound of approved make including curing, finish and cleaning etc. complete as directed by the SIA. The</p>	Sqft	500		

	measurements shall be based on laid area of floor and no extra payment shall be paid for wastage. The rates shall include cost of laying protective PVC sheets & POP which shall keep the floor covered at all times till handing over of the site etc. complete.				
4	Same as above skirting upto a height of 4".	Rft	300		
5	Providing and fixing 9 mm thick Armaflex floor insulation below the false flooring / above false ceiling and joints should be finished properly with adhesive tape as per manufacturer's specification. The rate shall be inclusive of jointing tap, cleaning the surface to make it free from dust.	Sqft	3000		
F	PAINTING				
1	Providing and applying acrylic plastic emulsion paint of approved make and shade to give an even shade over a primer coat as per manufacturers' recommendations after applying painting putty to level and plumb and finishing with 3 coats of plastic emulsion. Base coating shall be as per manufacturer's recommendation for coverage of paint.				
a	For Ceiling	Sqft	500		
b	For all vertical Plain surface	Sqft	4000		
c	For all vertical surfaces with Approved Texture Finish of approved pattern made using masking tape in non-texture areas and later removing the tape and finishing with plastic emulsion paint.	Sqft	Qro		
d	Same as above with design texture finished with plastic emulsion paint.	Sqft	Qro		
2	Providing and laying POP punning over cement plaster in perfect line and level with thickness of 10 - 12 mm including making good chases,	Sqft	2000		

	grooves, edge banding, scaffolding pockets etc. complete as per directions of SIA.				
3	Providing and applying Epoxy Paint for floor area of approved make and shade over a coat of primer and finishing with two coats of epoxy paints. The overall thickness not less than 320 microns.	Sqft	1000		
4	Providing and applying weather coat emulsion paint of approved make and shade to give an even shade over a primer coat as per manufacturer's recommendations after applying painting putty to level and plumb and finishing with 2 coats of weather coat emulsion. Base coating shall be as per manufacturer's recommendation for coverage of paint.	Sqft	Qro		
G	MISCELLANEOUS				
1	Providing and fixing Antistatic laminate with 25 mm Bison board steps and ramp based on vertical surfaces of raised floors with complete all respect. The rate shall be inclusive of 2.0mm thick Antistatic laminate and hardwares etc.,	Sqft	75		
2	Providing and fixing of 50mm Venetian blinds for windows / fixed glazing, etc. as per standard manufacturer specifications of approved colour etc. as directed by the SIA. The number of sections and its movement controls shall be decided based on site conditions.	Sqft	150		
3	Providing and fixing 100mm ledge with 12 mm thick bison board with antistatic laminate finish fixed in the gypblock partition to match with the floor colour as directed by SIA.	Rft	300		
4	Providing and fixing antiskid 3 M tape in the ramp at 6" intervals of approved colour and make as	Rft	180		

	directed by the SIA.				
5	Providing and fixing of 3 M "Etching Film" in door / windows as per approved shade and make etc. as per the drawing and as directed by the SIA.	Sqft	Qro		
6	Providing and fixing of "Sun Control Film" in door / windows as per approved shade and make etc. as per the drawing and as directed by the SIA.	Sqft	Qro		
7	Demolishing the existing brick wall with plastering. The rate shall be inclusive of removing, cleaning and disposing off the existing materials etc. complete.	Cu.m	20		
8	Providing and fixing 3M floor mat with approved make and colours near the entrance door as directed by SIA.	Sqft	Qro		
9	Providing and laying 230 mm thick brick work in cement mortar of 1:4 (1 cement : 4 sand) with bricks of approved quality chamber bricks of class designation 50 and having crushing strength not less than 50 Kg/Sft. Brick work shall be done in such a way that all joints are full of mortar. The thickness of joints shall not exceed 10 mm for brick work. All the face joints shall be raked to a minimum depth of 15 mm by raking tool during the progress of brick work. The rate shall be includes of mixing, scaffolding, raking of joints, curing etc.	Sqft	Qro		
10	Providing and laying 115 mm thick brick work in cement mortar of 1:4 (1 cement : 4 sand) with bricks of approved quality chamber bricks of class designation 50 and having crushing strength not less than 50 Kg/Sft. Brick work shall be done in such a way that all joints are full of mortar. The thickness of joints shall not exceed 10 mm for brick work. All the face joints shall be raked to a	Sqft	Qro		

	minimum depth of 15 mm by raking tool during the progress of brick work. The rate shall be includes of mixing, scaffolding, raking of joints, curing etc.				
11	Plastering with cement mortar including water proofing mix in cement of 12 mm thick in interior face of the walls and concrete columns including hacking the concrete surface brushing, G.I mesh, scaffolding, curing and surface shall be smooth trowel finish as per standard specification.	Sqft	Qro		
12	Removal and dismantling the of existing Materials from site like flooring including base mortar upto rcc slab level, false ceiling,furniture, underdeck insulation & all type of partition etc. The rate shall be inclusive of removing and handling over the materials to client. The debris should be removed from the site and disposed as per instruction.(Kindly inspect the site and quote the price accordingly)	Lot	1		
13	Removal of the existing window and handed over to the client without damaged. The rate shall be inclusive of chipping, finishing & cleaning the site.	Sqft	Qro		
14	Providing and laying 8 mm/12mm thick MDF board with approved colour and make of 1.5 mm laminate finish in window sill/ ledge etc. complete.	Sqft	Qro		
15	Providing and fixing 115mm thk brick wall will with 230mm thk intermediate brick columns @ 2.5m c/c fencing wall with rough plastering with 230mmx230mm size plinth beam allaround.	Sqft	Qro		
H	CHAIRS and TABLES				
a	Supply of productivity work chair having width 70 cms, Depth 70 cms , Height Adjustability 93 to 110 cms and adjustment of seat Height 45 to 55 cms with approved colour as Decision of DoIT with	Nos	30		

	seat height adjustment and tilting mechanism				
b	Supply of long back executive chair having width 65 cms, Depth 65 cms , Height Adjustability 119 to 131 cms and adjustment of seat Height 42 to 54 cms with approved colour as Decision of SIA and as per with seat height adjustment and tilting mechanism	Nos	2		
c	Supply of long back Visiting chair having width 57 cms, Depth 64 cms , Height 82 cms and of seat Height 46 cms with approved colour as Decision of SIA	Nos	2		
d	Supply of Sofa set made with thick high density polyurithane foam cushions for the seat and back upholstered and durable fabric to enhance comfort. The sofa set shuld have padded armrests with a convenient pouch tfor keeping newspapers, magzines and journals. The framework should be made from prime quality tubular steel to make the sofa rigid and longer lasting. The steel framework should be pretreated with spray phosphating, powder coated and oven baked s per approved drawing, colour to match with office decor and approval by DoIT in charge. Bidder has to offer 3 alternate reputed make of sofa manufacturer.				
d.1	Single seater (H x W x D ::74 x 60.5 x 74.5 cm)	No	1		
d.2	Three seater (H x W x D ::74 x 166.5 x 74.5 cm)	No	1		
d.3	Center Table (H x W x D ::40 x 54 x 94 cm)	No	1		
e	Supplying of Modular conference table suitable for 8 persons, top of the table should be either of teak / rose wood,/ cedor veneer to match the office décor. Triple melamine coating should be done to protect the wood veneer to make the table	No	Qro		

	top stain proof, water proof to give an attractive, superior and long lasting finish. Levelling screws should be provided at the bottom of the legs for a perfect balance on uneven flooring.				
I	Record protection equipment - Fire proof cabinets	Nos	1		
K	Any other item required to make the work/package complete	Bidder to specify item wise	Bidder to specify item wise		

Note: All detailed specification and working drawing prior to the execution to be submitted by the bidder

Samples of all furniture items shall be got approved by SIA/Authorized Person prior to their supply & installations.

1.3.2.1 Bill of Quantity: Electrical System

Sl.No (1)	Item description (2)	UOM (2)	QTY (3)	Make	Model
1	DIESEL GENERATOR	NOS	2+1		
	Supply, Installation, Testing and commissioning of 320 KVA (+/- 5%) DG set with acoustic enclosure confirming to latest environment protection regulation for emission and noise levels complete with diesel engine developing actual BHP calculated considering De-rating factor if any whichever is higher, water cooled, 4 stroke, electric start, turbo charged and after cool confirming to BS-5514 with all standard accessories coupled with Alternator of adequate rating, brushless, self excited, self regulated and suitable for continuous operation, generating 415 V +/- 5%Volts at 0.8 p.f. (lag), 50 Hz, 3 phase, 4 wire system generally conforming to BS 2613& IS: 4722. Both Engine and Alternator shall be mounted on common channel iron base frame, with standard accessories such as 4 Numbers of 12 V, 180 AH lead acid batteries along with leads, battery stand, day fuel tank, fuel piping from fuel tank to Engine, fuel tank to fuel storage tank, Residential silencer, suitable size termination box (Cable / Bus duct) with extended Alternator terminal with bus bars including control switchgear etc. as required and as per specifications. The DGs has to be supplied with all necessary electronic hardware and software to be integrated with the DG sync panel for synchronization. Cost of the DG includes DG and fuel tank platform and shed. It also included the				

	pumps, piping and integration of automatic fuel measurement system to be integrated with BMS.				
2	EXHAUST SYSTEM	NOS	2+1		
	Supply and fixing of following sizes of MS 'B' Class piping of suitable length as per site requirements with bends for Exhaust of DG Sets including providing suitable self supporting arrangement at suitable intervals, painting etc. and supplying and fixing MS pipe or as per Manufacturer recommendations mineral wool insulation on all sides of Exhaust pipe and silencer with chicken mesh wrapping and cladding with aluminium sheet, suitable for outside enclosure of DG Set complete as required including guide wherever required and as per specification. Supplying and fixing of 990 ltr Buffer service tank made of 2mm thick MS sheet with filling, drain, measuring scale, fuel indication, MS angle iron stand grouted on CC foundation and return connections as required.				
3	UPS SYSTEM	Nos	2		
	Supply, Erection, testing and commissioning of 80 KVA double conversion online UPS with active/passive filter to achieve the THDI as specified in the specification				
4	Battery Bank	Set	2		
	2V VRLA with long design life battery bank to achieve backup for 30 minutes on each UPS.				
5	Accessories				
a	Battery Breaker suitable for the above UPS and Battery bank	nos	2		
b	Stand (Base frame) for UPS systems and Batteries if required for raising the same till false	as required	lot		

	floor level				
c	Copper cable of adequate rating from UPS to battery	Mtrs	200		
d	Static Transfer Switch 16A	Nos			
6	UPS SYSTEM (for other load)	Set	1		
	Supply, Erection, testing and commissioning of 2 x 10 KVA Parallel redundant double conversion with active/passive filter to achieve the THDI as specified in the specification				
7	Battery Bank	Set	1		
	12V VRLA with long design life battery bank to achieve backup for 45 minutes at full load per UPS system with a cumulative back up for 90 minutes per set.				
8	Accessories				
a	Battery Breaker	Nos	2		
b	Stand (Base frame) for UPS systems and Batteries if required for raising the same till false floor level	as required	lot		
c	UPS to battery cable of adequate rating	Mtrs	60		
9	DG AMF Synchronisation cum auto load management panel	Nos	01		
	Design, fabrication, assembling, wiring, supply, installation, testing and commissioning of following switchgear panels fabricated out of 14 SWG CRCA sheet steel in cubicle compartmentalized powder coated free standing, floor/wall mounted, dust and vermin proof (IP54 minimum)suitable for 415 V, 3 phase, 4 wire, 50 Hz power distribution system. Cable gland plates shall be provided on top/bottom of the panels. 2 nos. earthing terminals shall be provided for all panels.The panel shall be complete with				

	aluminium bus bars of adequate rating, Adequate size cable alley, painting, earthing, numbering, danger plate etc as required. Separate earth bus bar shall be provided through out the length of the panel. The incoming and outgoing feeders shall be accommodated in a modular multitier arrangement. All incoming and outgoing feeders should be BMS compatible				
	Incomer 3 nos 400 Amps 3P microprocessor based MCCB, 35KA with SC,O/L, neutral contactor 150 A AC3 duty and earth fault protection including communicable port RS485 .				
	2 nos 800 Amps 4P microprocessor based MCCB ,35KA Buscoupler betweenDG 1& DG2 and DG-2 & DG-3 with SC,O/L & earth fault protection including communicable port RS485				
	3 nos 800 Amps 4P microprocessor based MCCB , 35KA outgoing SC,O/L & including communicable port RS485 with display at front facia.				
	4 nos energy analyzer, indication lamps for on/off,trip,synchro lamp,RYB lamps,synchro relays with synchroscope,load manager,PLC based priority selection,necessary control wirings,CT/PT,DG paramer display, name plates,danger boards etc as required for & as per specification but not limited to give the complete system as desired.				
	Note : Bidder has to propose the rating of the breaker as per their propose solution that fits the source and load Equipment and as per prévalant electrical standards. The entire solution ownership lies with the bidder.				

10	Main LT Panel	NOS	1		
	Design, manufacture, supply, installation, testing and commissioning of MAIN LT Panel, cubicle type, made of 14 SWG CRCA sheet steel, totally enclosed, IP-54, free standing, floor mounting, indoor, compartmentalized, powder coated suitable for operation on 3 phase and neutral 415V, 50 Hz AC system with bus bars extendable on both sides, interconnections including supply and installation of following items and as per specifications				
	A. INCOMER				
	3 Nos 800 Amps MCCB 50 kA,4 pole, microprocessor release, Motor wound spring charged closing mechanism. Each Incomer shall have one set of the following items:				
	Intelligent multi function digital meter to read VA, KVA KW, KVAR, PF, Hz etc with communication facility (RS 485 port) and LED display with 3 Nos CTs, 15 VA, class 1.0 and control circuit wiring with SP MCB . Indication Lamps, LED type, R.Y.B ad breaker 'ON', 'OFF', 'TRIP' lamps. One no of current transformer Class 0.5 VA for APFC Relay.				
	B. BUS BARS				
	Bus bars, 1200 Amps, TPN+E, Aluminium bus bar - 01 set				
	C. BUS COUPLER				
	MCCB 1000 Amps, 50kA, microprocessor release, Motor wound spring charged closing mechanism, EDO type, - 01 No Indication Lamps, LED type, for breaker ON', 'OFF', 'TRIP' indication with SP MCB control fuses- 3 sets				

	Suitable arrangement, interconnection required for electrical and mechanical interlock among 2 Nos. Incomers and 1 No Bus coupler - 01 Set				
	Outgoing Feeders:-				
	MCCB, 400 Amps, 4 Pole, 36 kA,microprocessor release - 2 Nos., 160 Amps, 4 Pole, 25 kA - 2 no MCCB, 100 Amps, 4 Pole, 25 kA - 1 nos MCB, 63 Amps, 4 Pole, 25 kA - 2 nos, 40 Amps, 4 Pole, 25 kA - 3 nos Indicating lamps LED type, for breaker "ON", "OFF", "TRIP" indication with SP MCB control fuses - 14 Sets.(only for ACBs)				
	Note: The above specification of the panel is minimum and indicative. The bidder has to propose the specs as per their solution offered. Choice of ACB and MCCB is left to the bidders to propose as per the solution offered. The basic principle of operation must not be compromised.				
11	APFC panel (Optional)	NOS	1		
	<p>300 kVAR automatic/manual Power Factor Correction Panel fabricated out of 2mm CRCA Sheets Modular, compartmentalized, Free Standing, Floor Mounting, Front hinged doors for indoor use, removable bottom gland plates for incoming cables, dust and vrmn proof (IP: 42 protection) with TP Aluminium Busbars, complete with busbar connection, internal wiring, name plates, painting with details as follows</p> <p>Rating of APFC Panel 300 kVA Rated Voltage of the Panel 440 V AC, Frequency 50 Hz No.of Phases =3 Phase Enclosure details: Free Standing, Floor mounted,</p>				

	<p>Compartmentalized Design.</p> <p>Material :CRCA</p> <p>Thickness of Sheet Steel Used: Frame-2.0mm</p> <p>Doors-2.0mm</p> <p>Partitions-1.6mm</p> <p>Dimensions 3000 (L) x 2200 (H) x 800 (D) (approx)</p> <p>Protection IP-42</p> <p>Application Indoor</p> <p>Painting Shade Siemens grey RAL 7032</p> <p>Busbar Material :Aluminium Cross Section 2 x 60 x 10 mm</p> <p>Busbar support : SMC</p> <p>Capacitors Type: MD-XL,500 V, 3 ph, 50 Hz (Cylindrical)</p>				
12	PAC Panel	NOS	2		
	Design, manufacture, supply, installation, testing and commissioning of PAC Panel, cubicle type, made of 14 SWG CRCA sheet steel, totally enclosed, IP-54, free standing, floor mounting, indoor, compartmentalized, powder coated suitable for operation on 3 phase and neutral 415V, 50 Hz AC system with bus bars extendable on both sides, interconnections including supply and installation of following items and as per specifications				
	A. INCOMER				
	1Nos 200 Amps microprocessor based MCCB 25 kA 4 pole				
	B. Outgoing				
	46nos 63 Amps microprocessor MCCB 16 kA 4 pole				
	Outgoing Feeders:-				

	Intelligent multi function digital meter to read V,A,KVA KW, KVAR, PF, Hz etc with communication facility (RS 485 port) and LED display with 3 Nos CTs, 15 VA, class 1.0 and control circuit wiring with SP MCB control fuses				
13	Lighting DB	NOS	2		
	Supply, erection, testing & commissioning of following double door Distribution Boards including surge arrester for each phase(For Light DBs only) :- 12 way TPN				
	Incomer - 63 Amps TPN - 1nos				
	Outgoing - 36 nos SP MCB				
14	Power DB	NOS	2		
	Supply, erection, testing & commissioning of following double door Distribution Boards including surge arrester for each phase(For Light DBs only) :- 12 way TPN				
	Outgoing - 35 nos SP MCB				
	Incomer - 63 Amps TPN - 1nos				
	Outgoing - 36 nos SP MCB				
15	UPS DB (other than Rack Load)	NOS	2		
	Supply, erection, testing & commissioning of following Distribution Boards including surge arrester for each phase(For Light DBs only) :- 12 way TPN Incomer - 63 Amps TPN - Outgoing - 36 nos SP MCB,				
16	UPS OUTPUT PANEL/PDU (for Rack Loads)	NOS	2		
	Design, manufacture, supply, installation, testing and commissioning of UPS output Panel, cubicle type, made of 14 SWG CRCA sheet steel, totally enclosed, IP-42, free standing, floor mounting, indoor, compartmentalised, powder coated suitable for operation on 3 phase and neutral				

	415V, 50 Hz AC system with bus bars extendable on both sides, interconnections including supply and installation of following items and as per specifications				
	Incomer: 250 Amps 36 kA 4 pole microprocessor based MCCB 1 no.				
	Outgoing : 16 Amps SP MCB – 8 no. 32 Amps SP MCB – 26 No. 32 Amp TP MCB – 10 no, 63 Amp TP MCB – 4 no. Plus atleast 10% spare to be included in each rating Intelligent multifunction digital meter to read V, A, KVA, KW, KVAR, pf. Htz with communication facility (RS 485 port) and Led Display with 3 no. CTs 15 VA with class I and control circuit wiring with SP MCB control fuses.				
17	CABLING	Mtrs.			
	Supplying and laying the following sizes of 1100 volt grade, PVC insulated and armoured, copper or aluminium conductor cables. Rate to include for all necessary fixing hardware cable clamps, trays, M.S. supports and hangers etc.for cables laid indoors or in ready trench and excavation, provision of sand, bricks, cable markers etc. and backfilling for cables laid underground:				
	a) 4 core x 4 sq. mm. Cu armoured Cable	Mtrs.	100		
	b) 3 core x 6 sq.mm. Cu. flexibe cable	Mtrs.	100		
	c) 4 core x 6 sq.mm. Cu. Armoured	Mtrs.	150		
	d) 4 core x 16 sq.mm. Cu. Armoured	Mtrs.	50		
	e) 4 core x 25 sq.mm. Cu. Armoured	Mtrs.	250		

	f) 4 core x 35 sq.mm. Cu. armoured cables	Mtrs.	50		
	g) 1 core x 95 sq.mm. Cu. armoured cables	Mtrs.	450		
	h) 3.5 core x 240 sq.mm. Al. armoured cables	Mtrs	300		
	i) 1 core x 70 sq.mm. Cu. flexible cables	Mtrs.	100		
	j) 3.5 core x 150 sq.mm. Al. armoured cables	Mtrs.	150		
	k) 3.5 core x 70 sq.mm. Al. armoured cables	Mtrs.	200		
	l) 4 core x 4 sq.mm. Cu. flexible cables	Mtrs.	100		
18	Jointing the ends of the following sizes of PVC insulated and armoured cables including supply of brass cable glands, cable sockets and all jointing materials:				
	a) 4 core x 4 sq. mm. Cu armoured Cable	NOS	01		
	b) 3 core x 6 sq.mm. Cu. Armoured	NOS	01		
	c) 4 core x 6 sq.mm. Cu. flexible cable	NOS	01		
	d) 4 core x 16 sq.mm. Cu. Armoured	NOS	12		
	e) 4 core x 25 sq.mm. Cu. Armoured	NOS	24		
	f) 4 core x 35 sq.mm. Cu. armoured cables	NOS	40		
	g) 1 core x 95 sq.mm. Cu. armoured cables	NOS	64		
	h) 3.5 core x 240 sq.mm. Al. armoured cables	NOS	16		
	i) 1 core x 70 sq.mm. Cu. flexible cables	NOS	24		
	j) 3.5 core x 150 sq.mm. Al. armoured cables	NOS	24		
	k) 3.5 core x 70 sq.mm. Al. armoured cables	NOS	16		
	l) 4 core x 4 sq.mm. Cu. flexible cables	NOS	24		
19	Cable Trays and Steel fabrication work	Mtrs.	32		
	Supply erection, testing and commissioning of prefabricated perforated type MS cable trays including Tees / Bends / Crossing / Reducers / Couping including supports / Brackets / Base frames of various sizes including straighting , cutting, welding on existing structure , grouting, leveling etc to be generally laid in false floor / cable trench or as per site requirement.				
	a) 600 (W) x 50 (H) x 2mm (T)	Mtrs.	60		

	b) 450 (W) x 50 (H) x 2mm (T).	Mtrs.	50		
	c) 300 (W) x 50 (H) x 2mm (T)	Mtrs..	100		
	d) 150 (W) x 50 (H) x 2mm (T)	Mtrs.	60		
20	Providing and laying 2.0 MM thick MS factory (as per the approved make in list) fabricated raceways in partition of the following sizes including providing removable 3 mm thick MS cover knock out holes and fixing accessories complete as required including floor supports, bends, access boxes and tap off boxes as per specification and cross over as per site requirement				
	a) 450 mm wide x 100 mm deep raceway	Mtrs	80		
	b) 400 mm wide x 100 mm deep raceway	Mtrs	60		
	c) 150 mm wide x 100 mm deep raceway	Mtrs	20		
21	Providing and fixing junction box including providing 3 mm thick stainless steel cover required as per specification.				
	a) 450x450x120	Nos	10		
	b) 550x550x120	Nos	10		
	c) 200x200x120	Nos	8		
22	EARTHING				
	a) Supply, installation, testing and commissioning of 3.0 meter long gel type earthing with earth pipe set back fill compound, bus for termination, SS bolts, nuts, and washers etc. including excavation, refilling & complete as required, including heavy duty cast iron cover and all associated civil works like construction of chamber and rough plastering etc. The electrode material should be 99% Cu and dia should be 10mm (minimum)	Nos.	8		
	b) Supply, installation, testing and commissioning	Nos.	16		

	of 600 X 600 X 3 mm copper Plate Type Earthing with alternate layers of charcoal & salt including excavation, refilling & complete as required, including heavy duty cast iron cover and all associated civil works like construction of chamber and rough plastering etc				
	c) Earthing of framework of all metal clad switchgear, cable armouring etc. using the following bare Cu. conductors:				
	1) 50 mm x 5 mm Cu. Strip	Mtrs.	400		
	2) No. 8 SWG Cu. Wires	Mtrs	100		
	3) No. 12 SWG Cu.wires	Mtrs.	200		
	4) No. 14 SWG Cu wires	Mtrs	200		
	5) 20 mm x 3 mm tinned Cu. braided tape	Mtrs.	75		
	6) 300 X 50 x 6 mm tinned copper earth busbar with insulators.	Nos.	4		
23	LIGHTING & POWER WIRING				
	Providing wiring to the following light points using 1.5 sq.mm. (3 / 0.80 mm) single core, 1100 volt grade, PVC insulated copper conductor wires drawn in heavy gauge PVC conduit pipes installed on the ceiling or run over the false ceiling with drops to the distribution boards and switch boxes recessed in the walls/partitions. Points to be controlled in groups or individually by means of 6 amps, single pole, flush type modular switches housed in flush mounted G.I. boxes. Rate to include for 1.5 sq.mm green PVC insulated, single core, copper earth wire drawn in the conduit pipe for earthing the light fittings & each light will be measured as one point.				
	a) Points to be controlled in groups of 4-6 from	Points	25		

	the lighting switch box				
	b) Points to be controlled in groups of 2-3 from the lighting switch box	Points	15		
	c) Points to be controlled individually from the lighting switch box	Points	20		
24	Providing wiring as described above but to 6 amps socket-outlets and each point to be complete with a 6 amps, 2-pole and earth switch socket-outlet housed in a flush mounted G.I. box recessed in walls/partitions	Points	25		
25	Providing wiring to electrical points for the security system, as described, including flush mounted boxes but excluding any switch or socket-outlets	Points	25		
26	Providing wiring to 16 amps socket-outlets, using 2 x 4 sq.mm. + 1 x 2.5sq. mm.) single core 1100 volt grade, PVC insulated copper conductor wires drawn in heavy gauge PVC conduit pipe & each point to be complete with 1 No. 6A + 1 No. 16A flush mounting switch socket-outlets housed in a flush mounted G.I. box	Points	20		
27	Supplying and installing the following IP 55 2-pole + earth, single phase, 250 volts, inter-locked switch socket-outlet with plug housed in a surface mounting metal enclosure				
	a) 16 A interlocked socket-outlet	Nos.	8		
	b) 32 A interlocked socket-outlet	Nos.	64		
28	Supplying and installing the following IP 55, 415 volts, 3-phase, neutral and earth interlocked switch socket-outlet with plug housed in a surface mounting metal enclosure)				
	a) 32 A interlocked socket-outlet	Nos.	20		
	b) 63 A interlocked socket-outlet	Nos.	6		

	Underfloor Ducting System				
29	Supplying and installing 125 mm wide x 50 mm deep G.I. two compartment, under floor ducting fabricated from 1.6 mm thick CRCA sheet steel and with pregalvanised finish. The ducting shall be completed with electrical joints, covers and all necessary assembly components and fixing hardware.	Mtrs.	60		
30	Supplying and installing 175 mm x 175 mm x 65 mm deep fabricated zinc plated M.S. floor junction boxes with two compartment flyover or divider arrangement and complete with end blocking plates, fasteners and all necessary fixing hardware etc.	Nos.	40		
31	Supplying and installing in the under floor ducting system, 3-core x 2.5 sq.mm. 1100 volt grade, PVC insulated and PVC sheathed, copper conductor flexible cables. (A group of workstations may be looped on one circuit from the DB)	Mtrs	200		
32	Supplying and installing in the modular furniture workstation panels, flush mounting type 1 No. 16 amps S.P. switch controlling 2 Nos. 6 amps, 2/3 pin socket-outlets + 1 No. 16 amps S.P. switch controlling 1 No.6/16 amps socket-outlet fixed on flush mounted G.I. boxes and rate to include for all miscellaneous wiring items viz. flexible PVC conduit, fixing hardware and connections etc	Nos.	30		
	NOTES:				
	1) Rates for all point wiring shall include for sub-circuit mains from the distribution boards upto the switch/socket-outlet boxes.				
	2) The number of wires drawn in the conduit pipe				

	and the number of points per circuit shall be limited as specified in the I.S. Code of Practice				
	LIGHTING FIXTURES				
33	Supplying and installing the following fixtures wired with high Frequency ballasts, lamp holders and complete with lamps				
	1 x 28 watts slimlite Fixtures with electronic ballast	Nos.	10		
	2 x PL - L 36 watts decorative pearl white direct luminaire for modular ceiling	Nos.	65		
	4 x 18 watts decorative recessed mounting luminaire	Nos.	50		
	1 x PL - C 18 watts recessed mounting Downlight luminaire with recessed glass – Raindrops	Nos.	10		
	2 x PL - C 18 watts recessed mounting Downlight luminaire with recessed glass – Raindrops	Nos.	20		
34	Supply and installation of PIR detectors for switching above lights	Nos.	As required		
35	PAC auto changeover switch as per the specs given in technical specification	Nos	4		
36	LCD Projector	Nos	1		
37	32 " High definition Plasma TV	Nos	1		
	Any other item required to make the package/work complete.	Bidder to specify item wise	Bidder to specify item wise		

1.3.2.2 Bill of Quantity: Air Conditioning System

SI.No (1)	Item description (2)	UOM (3)	QTY (4)	Make	Model
1.0	PRECISION PACKAGED UNITS				
	<p>Supply, Installation, Testing and Commissioning of air cooled precision type packaged air conditioning units, self contained floor discharge type complete with scroll multiple compressors, fan section with dynamically balanced backward curved fan driven by Electronically commuted (EC) Motor, multirows deep cooling coil of copper tubes and aluminium fins, remote aircooled condenser with copper tubes and aluminium fins, copper refrigerant piping and thermostatic expansion valve. Enclosure shall be fabricated out of MS sheets supported on a fabricated steel structure. The unit shall be equipped with synthetic fibre filters, drain pan, micro-processor based programmable logic controller, Graphic display, humidifier, heaters, Wet floor sensor, etc. all complete in a unit as per the specifications. The enclosure shall be factory painted to a smooth finish. The precision unit shall also be complete with electrical panel comprising of indication lights, and necessary control wiring. The packaged units shall be complete with auto</p>				

	sequencing units shall be complete with auto sequencing arrangement as required and shipped out of factory suitable for R407c refrigerant charge. The compressor shall be suitable for operation on 415 ±10% volts, 50 Hz three phase AC power supply. Fan Static shall be minimum 7mm (70pa) consider 25pa as external static pressure. Quoted price shall be inclusive of MS base frame duly painted with the black enamel paint for mounting of remote air cooled condensers.				
	12 TR (min) sensible capacity (at Indoor Condition 21 Deg C & 50% RH, Outdoor Condition 5 to 42 Deg C), 7000 CFM with min 7mm External static pressure, Precision air-conditioning unit for Data Center.	No.	6		
	The Bidder has to indicate the EER / COP value of PACs				
1.1	Installation & Commissioning				
	(Distance between indoor & outdoor units 40 Rmt) with first charge of gas with electrical cabling between indoor unit (IDU) & outdoor unit (ODU), Refrigerant Copper Piping alongwith IDU & ODU Stands. Humidifier makup water piping considering distance as 5 Rmt each unit.	No	6		
2.0	EXTENDED PIPING KIT				
	(Required if separation between	No	6		

	indoor & outdoor units exceeds 30 RM). Supply, Installation, Testing and Commissioning of extended piping kit complete with check valves, electronic solenoid valves, u bends copper piping, cabling etc. as required.				
3.0	Supply, Installation, Testing and Commissioning of following GI drain piping for indoor units complete with necessary elbows, tees, reducers etc. The pipe shall be insulated with 9mm thick closed cell elastomeric tubing and secured with adhesive type of matching colour.				
	a. 50mm dia pipe	RM	50		
	b. 40mm dia pipe	RM	R/O		
	c. 25mm dia pipe	RM	60		
4.0	Sequencing Controller	Nos	1		
5.0	Monitoring system of all Precision Aircondition units - Network interface Card for BMS Integration including cabling	No	1		
6.0	Supply air grills with volume control damper	Lot	qro		
7.0	Return Air Grills	Nos	qro		
8.0	Retun Air Motorised Damper	Nos	4		
9.0	Floor & ceiling insulation (9mm thick nitrile rubber with Aluminium foil)	Sqmt	qro		
10.0	Comfort cooling system				
01	2TR wall mounted Split AC system with highest star rating (highest EER). The job include supply and		010		

	installation of laying of Cu pipe with insulation, drain pipe, installation of outdoor unit with stand, remote regulating unit, Voltage stabilizer if required and accessories etc. Vendor has to propose the outdoor unit location and quote the length of the pipe accordingly. No extra payment will be made for pipe length.				
02	1.5TR wall mounted Split AC system with highest star rating (highest EER). The job include supply and installation of laying of Cu pipe with insulation, drain pipe, installation of outdoor unit with stand, remote regulating unit, Voltage stabilizer if required and accessories etc. Vendor has to propose the outdoor unit location and quote the length of the pipe accordingly. No extra payment will be made for pipe length.		06		
03	1.5TR ceiling mounted Cassette AC system with highest star rating (highest EER). The job include supply and installation of laying of Cu pipe with insulation, drain pipe, installation of outdoor unit with stand, remote regulating unit, Voltage stabilizer if required and accessories etc. Vendor has to propose the outdoor unit location and quote the length of the pipe accordingly. No extra payment will be made for pipe length.		03		
04	2TR window AC system with highest		01		

	star rating (highest EER). The job include supply and installation, Voltage stabilizer if required and accessories etc.				
05	1.5TR window AC system with highest star rating (highest EER). The job include supply and installation, Voltage stabilizer if required and accessories etc.		01		
18	Any other item required to make the package / work complete	Bidder to specify item wise	Bidder to specify item wise		

1.3.2.3 Bill of Quantity: Safety and Security Systems

SI.No (1)	Item description (2)	UOM (3)	QTY (4)	Make	Model
A	Addressable Fire Alarm Systems				
	Supplying, installing, testing & commissioning of the following as per specification complete with junction box as and where required along with successful commissioning complete system, all inter connections etc.				
1	Addressable control modules complete with junction box etc. in everyway for Hooters & for other control options like PA evacuation, Access Doors opening in emergency and as per specification.	Nos.	12		
2	Addressable monitoring modules complete with junction box etc. in everyway to connect conventional detection devices, manual call points, flow switches, supervisory switches etc.	Nos.	4		
3	Intelligent Analogue addressable photo electric type smoke detector with Blinking LED's complete with junction box etc. as per specification.	Nos.	25		
4	Response indicator with LED.	Nos.	10		
5	Addressable type Manual Pull Station as per specification.	Nos.	2		
6	Electronic Hooter Cum Strobe as per specification.	Nos.	2		
7	Supply, installation, testing and commissioning of isolator module complete with junction box and mounting accessories complete as per specification.	Nos.	2		

8	CO2 4.5 Kg capacity portable fire extinguisher	Nos.	1		
9	5 Kg ABC Type fire extinguisher	Nos.	4		
10	2 Kg NAF PIV Fire Extinguisher	Nos.	2		
11	Intelligent Analogue Addressable Microprocessor based 1 loop Fire Alarm panel with each loop connecting to minimum 125 addressable detectors & minimum 125 addressable modules complete with minimum 168 - character LCD display, integrated with sufficient battery back up for 24 Hrs. Stand-by in Normal Condition & 1/2 Hrs. in Alarm Condition as per specifications. The Fire Alarm Panel should be complete with all software / hardware required for seamless integration to the Building Management System as per specification.	Nos.	1		
12	Microprocessor based Active Repeater Panel complete with minimum 168 character LCD display. The repeater panel shall be capable of acknowledging the alarms as per specification.	No.	1		
13	Supplying, laying, testing, commissioning of 2 x 1.5 sq.mm copper conductor armoured FRLS cable to be laid in MS conduit of appropriate size and approved make	RM	700		
B	ACCESS CONTROL SYSTEM				
1	12 Door Control Unit for Access Control with hot-redundancy, microprocessor based , communicating on TCP/IP, tamper protected wall-mount case.	Set	1		
2	Dual reader interface module for connecting	Nos.	11		

	below smart card & biometric readers				
3	Low power 12 VDC power supply with internal battery backup for 4 hours operation.	Nos.	2		
4	Smart card Readers i-class or mifare technology with 2" read range capable of reading the facility code and unique card number from the card and also shall read the card data and passes on to the door controller for validation, UL listed complete as per specification	Nos.	14		
5	Smart Cards (Blank faced) with option of printing directly on card complete as per specifications	Nos.	100		
6	Electromagnetic Locks (600 lbs) with Magnetic Contact UL listed for single leaf doors complete as per specifications	Nos.	5		
7	Electromagnetic Locks for Double Doors (2x600 lbs) with Magnetic Contact UL listed for single leaf doors complete as per specifications	Nos.	10		
8	Emergency Door Release (Break Glass Type) complete as per specification	Nos.	9		
9	PUSH TO EXIT panic exit device for aluminium, hollow metal and wooden door, single leaf doors UL listed	Nos.	5		
10	1:N authentication Biometric Finger Print Reader with inbuilt smart card reader ,UL listed complete as per specifications	Nos.	1		
11	Access Management Software license in BMS Software complete with Graphic User Interface, Time & Attendance software – transactions, Anti passback features	Set	1		

	complete as per specifications.				
12	Panic Bar with hooter for fire exit doors	Nos.	1		
13	Supply and surface laying 8 core, 1.0 sq.mm cable.	Mts.	300		
14	Supply and surface laying of 3 Core, 1.5 sq. mm. copper conductor cable	Mts.	200		
15	Supply and surface laying of 4 Core, 1.5 sq.mm copper conductor cable	Mts.	300		
16	25mm PVC conduit	Mts.	400		
C	CCTV surveillance system				
1	1/3" CCD, 530TVL, 0.1lx (F1.2.), Internal Sync., AWB/ BLC/ AGC Mirror On-Off Control, 3.6mm fixed lens, DC12V, PAL (Dome Camera) complete with power supply and accessories.	Nos.	13		
2	4.8" Dome, TDN, Optical 35x, Digital 12x, 480TVL, 0.0001 lx (TDN, DSS), 248 preset (Max. 380°/sec), 8 tour, 4 patterns, 16 Auto Scan / 1 Auto Pan, Multi-protocol, AC24V, PAL	Nos.	1		
3	Indoor pendant type Housing for PTZ speed dome camera	Nos	RO		
4	Ceiling mount bracket for PTZ Camera housing	Nos	RO		
5	16-Channel Video, 1-Ch audio Embedded DVR, 400ips display and 400 ips recording, 250GB HDD built, CDRW, PAL, capable of 2 Internal SATA HDDs + 1 External SATA (Expandable up to 4TB)	No	1		
6	29" Color Monitor (LCD)	No	1		
7	RG - 59 Co-axial cable for Video signals	Mtrs.	300		
8	2 core 1.5 sq.mm PVC Insulated copper conductor Cable	Mtrs.	200		

9	25mm PVC Conduit	Mtrs.	400		
D	VESDA				
	Supply, Installing, Testing & Commissioning of the below as per specifications:				
1	VESDA 4 Zone Unit Capable of Integration with BMS	Nos.	1		
2	Power Supply Unit	Nos.	1		
3	Aspiration Tubes, Capillary Tubes, Nozzles, accessories, etc.	Lot	1		
4	25mm PVC Conduit	Mts.	200		
E-1	Gas Suppression System for Server room				
	Supply, installation, testing & commissioning of NOVEC1230 OR INERGEN Gas Based Fire Suppression System. Bidder has to supply extra cylinder with gas for testing purpose.				
1	80 Ltr Cylinder with Valve Assembly	Nos	5		
2	NOVEC1230 OR INERGEN Agent filled in the above cylinder (Kg.)	Kg	300		
3	Master Kit	Nos	1		
4	Slave Kit	Nos	5		
5	80 Ltr Cylinder Strap	Nos	5		
6	NOVEC1230 OR INERGEN Nozzles	Nos	8		
7	Warning Sign Stickers	Nos	1		
8	Manifold with 12 check valve	Nos	1		
9	Manifold with 6 check valve	Nos	1		
10	Abort Switch	Nos	1		
11	Release Switch	Nos	1		
12	Local Discharge Pressure Switch	Nos	1		
13	Gas release Panel with Module	Nos	1		
14	Piping as per Sch 40, ASTM A106 Gr B	Lot	1		
E-2	Gas Suppression System (FOR UPS & Panel room)				

	Supply, installation, testing & commissioning of NOVEC1230 OR INERGEN Gas Based Fire Suppression System. Bidder has to supply extra cylinder with gas for testing purpose				
1	80 Ltr Cylinder with Valve Assembly	Nos	3		
2	NOVEC1230 OR INERGEN Agent filled in the above cylinder (Kg.)	Kg	170		
3	Master Kit	Nos	1		
4	Slave Kit	Nos	3		
5	80 Ltr Cylinder Strap	Nos	3		
6	NOVEC1230 OR INERGEN Nozzles	Nos	6		
7	Warning Sign Stickers	Nos	1		
8	Manifold with 12 check valve	Nos	1		
9	Manifold with 6 check valve	Nos	1		
10	Abort Switch	Nos	1		
11	Release Switch	Nos	1		
12	Local Discharge Pressure Switch	Nos	1		
13	Gas release Panel with Module	Nos	1		
14	Piping as per Sch 40, ASTM A106 Gr B	Lot	1		
F	Building management System				
1	Software and Operator Workstation				
a	PC with Intel –core 2 duo Processor,2 GB DDR3 RAM, 100 / 1000 Mbps NIC for network connection,500 GB SATA HDD, 19" TFT-LCD Screen complete with OS, MS Office and anti virus software, A-4 Inkjet Printer complete as required.	Nos.	1		
b	UL listed Necessary Software Packages containing Building Management & Control Software Programmes with Dynamic Graphics interfaces complete as per specification.	Nos	1		

2	Supervisory Controllers				
a	TCP/IP based freely programmable native BACnet 32 bit network controller having built-in BACnet router with one BACnet IP network and 3 MSTP BACnet networks. Each network should support max. 30 BACnet MSTP controllers. The network controllers will have an in-built real time clock and configuration of base 24 input and output points expandable to 128 by using extension modules.	Lot	1		
b	BACnet MSTP based freely programmable 32 bit DDC Controller having peer-to-peer communication and in-built real time clock with housing enclosures as per enclosed data point summary with minimum 20% spare capacity for expansion.				
c	DDC Controllers as per IO Summary	Lot	1		
3	Field instruments				
a	Wall/ceiling Mount Temperature cum humidity Sensor (+/- 3% accuracy)	Nos.	12		
b	Contactors with relay output & switch complete as required for Emergency Power Off of Entire Data Center by tripping the MCCB's/Contactors	Nos.	6		
4	Software and / or Hardware required for Integration with BMS				
a	Integrator for Multi-Function Energy Meters (MODBUS Communication Protocol) (3 Nos.)	Nos.	1		
b	Integrator for Networked Precision A/c Units (5 Nos.)	Nos.	1		
c	Integrator for Networked UPS System (4	Nos.	1		

	nos.)				
d	Integrator for Networked VESDA Panels (1 nos.)	Nos.	1		
e	Integrator for Fire Alarm System	Nos.	1		
f	Integrator for Access Control System	Nos.	1		
g	Integrator for DG System (2 Nos.)	Nos.	1		
5	Cabling and Conduiting				
a	Communication Cabling (3c x 1.5 sq.mm, Shielded copper conductor cable)	Mtr	350		
b	Signal Cabling (2c x 1.5 sq.mm copper conductor cable)	Mtr	400		
c	25 mm PVC conduit	Mtr	300		
G	Water leak detection system				
	Supply, Installing, Testing & Commissioning of the below as per specifications:				
1	4 Zone Water Leak detection Panel with LCD display, power supply & battery back-up and Water Leak detection Module resistant to oxidation and erosion having a relay output for connection to the controller.	Nos.	1		
2	Water leak detection Tape Sensor	MTR	250		
3	Sounder	Nos.	1		
4	Supply and surface laying of 2Cx 1.5 sq.mm Cable	Mtr	80		
5	Supply and surface laying of 25mm PVC conduit	Mtr	40		
H	Rodent Repellent System				
1	Master Console capable of connecting to 12 Satellites complete with all accessories as per specifications	Nos.	3		
2	Satellite Units complete as per the specification	Nos.	35		
3	Connecting Cables	RM	400		

4	Bracket Stand	No.	2		
5	Supply & laying of 25mm PVC conduit	Mtrs.	250		
I	Public Address System				
1	4 Zone selection panel complete with interface for fire tone generator and Paging Announcement System	No	1		
2	Microphone	No	1		
3	200 W Amplifier	No.	1		
4	19" Rack to mount the above	No.	1		
4	Ceiling Mount Speaker - 6 W	Nos.	10		
6	Supply and Surface laying of 2 x 1.0 Sq.mm PVC Insulated copper conductor cable.	Mtr.	150		
	25mm PVC Conduit	Mtr.	200		
	MISCELLANEOUS				
A	SAFETY MASK for people to enter into the UPS room incase of smoke inside the room	Nos	1		
B	Hammer (min 500g made of Iron/steel) with stand and braket to break the glass pane in the server room	No	1		
C	Danger notice plate of appropriate size as per statutory rules	Nos	4		
D	Fire aid charts in laminated sheets of appropriate size	Nos	2		
E	1 set fire bucket	Nos	1		

1.3.2.4 Bill of Quantity: Passive Networking

Sl.No	Item description	UOM	QTY A	Make	Model
A	Copper Connectivity				
1	CAT6 UTP Cable (Grey)	BOX	33		
2	24-port unloaded Modular Jack Panel (for UTP Jacks only), 1U	Nos	22		
3	24-port unloaded Modular Jack Panel (for UTP Jacks only), 1U	Nos	22		
5	Cat-6 I/O Red	Nos	1056		
6	CAT6 Patch Cord Blue, 7 Feet	Nos	528		
7	CAT6 Patch Cord Blue, 10 Feet	Nos	528		
B	Fiber Connectivity				
1	6 Core MM Fiber	Nos	800		
2	6 Port Loaded LIU	Nos	20		
3	24 Port Loaded LIU	Nos	12		
4	SC Connectors	Nos	400		
5	SC-LC duplex Patch Chord - 5mtr.	Nos	200		
E	Racks				
1	36 U Rack	Nos	11		
2	Vertical Wire Manager (6" Wide x 6.76" Depth x 84" Height)	Nos	12		
3	Horizontal Cable Manager -2U	Nos	40		
F	DC support area Connectivity				
1	CAT6 UTP Cable (Grey)	BOX	6		
2	CAT-6, 24-port loaded Jack Panel	Nos	2		
3	Dual port face plate.	Nos	38		
4	Cat-6 I/O Red	Nos	38		
5	CAT6 Patch Cord Blue 3 Mtr	Nos	76		
G	Other Components				
1	Supply of 300 mm wide Cable raceway made out of 1.6mm thick GI sheet with covers.	Rmt.	50		

2	Supply of 150 mm wide Cable raceway made out of 1.6mm thick GI sheet with covers.	Rmt.	50		
3	Supply Of 25 mm PVC Conduit/Flexible	Rmt.	100		
H	Installation Services				
1	Fixing & Laying of 300 mm wide Cable raceway made out of 1.6mm thick GI sheet with covers.	Rmt.	150		
2	Fixing & Laying of 150 mm wide Cable raceway made out of 1.6mm thick GI sheet with covers.	Rmt.	150		
3	Laying of 25 mm PVC Conduit/Flexible	Rmt.	100		
4	Laying of UTP Cable	Rmt.	11895		
5	Termination Of Information Outlet	Nos	38		
6	Termination of Jack Panel	Nos	46		
7	Scanning Of UTP Nodes	Nos	474		
8	Installation and laying of 12 Fiber MM OM3 Multi Point Outlet to LC Fanout Cable Assembly	Nos	24		
9	Installation of Multi Point Outlet Fiber Optic Cassettes, SC, 6 Duplex Ports (50/125 micron Multimode)	Nos	24		
10	Installation Of Fiber Optic Enclosure	Nos	2		
	Fixing and Installation of 36 U open rack		3		
I	Closed rack for housing servers and related equipment with front and back perforation. Rack size is 600mm x 1000 mm. All required mounting accessories has to be included. All racks should have seprate locks and keys with unique numbers.	Nos	10		

J	Voice Connectivity				
1	Cat 5e UTP Cable	Box	4		
2	Cat 5e Information outlets	Nos	40		
3	Single Port Face Plate with Box	Nos	40		
4	CAT5e, Jack Panel, 24 port	Nos	6		
5	CAT 5e Patch cord, 7 ft	Nos	40		
6	25 Pair Riser Cable	Mtr.	20		
7	50 Pair Wiring block.	Nos	2		
K	IP based KVM solution for 30 server racks with 4 server per rack to be accessed by 4 monitor consoles from the NOC area. Complete solution to be provided including accessories and cabling	Lot	1		

1.3.3 Bill Of Quantity: Networking Components

SI.No	Item description	UOM	QTY X	Unit Rate INR Y	Make	Model
A	NETWORK EQUIPMENTS					
1	LAN Switch Core	No's	2			
2	LAN Switch Access	No's	6			
3	INTERNET Router	No's	2			
4	Firewall Internet	No's	2			
5	Intrusion Prevention System	No's	2			
6	End Point Protection for Servers and PCs (HIDS/ HIPS)	No's	For all servers and PCs supplied by DCO			
7	Server Load Balancer	No's	2			
8	Authentication, Authorization and Accounting	No's	1			

Note : Bidder has to mention quantity of the item over and above the mentioned quantity which shall be sufficient to meet the scope/ objective of State Data Center.

1.3.4 Bill Of Quantity: Management, Monitoring & Helpdesk SYSTEM (EMS)

SI.No	Item description	UOM	QTY X	Make	Model
A	EMS solution having all the modules defined in technical specifications.	Set	1		
B	EMS Server	Nos	Min 3		

Note : Bidder has to mention quantity of the item over and above the mentioned quantity which shall be sufficient to meet the scope/ objective of State Data Center.

1.3.5 Bill Of Quantity: Platform and Storage

SI.No	Item description	UOM	QTY X	Make	Model
1	Blade Chasis	Nos.	As per Bidder's sol		
2	Application Web Server Interface: X64 Architecture	Nos	3		
3	Application Web Server Interface: RISC/EPIC Architecture	Nos	2		
4	Application Server: X64 Architecture	Nos	3		
5	Application Server: RISC/EPIC Architecture	Nos	2		
6	Database Server: X64 Architecture	Nos	3		
7	Staging Server	Nos.	1		
8	SAN Storage	Nos	1		
9	SAN Switch	Nos	2		
10	Backup Solution	Nos	As per		

			Bidder's Sol		
11	Directory, DNS, DHCP Server	Nos	2		
12	Antivirus Server	Nos	1		
13	Backup Server	Nos	1		
14	Management Server	Nos	1		
15	IP KVM	Nos	5		
16	Storage replicator for (Diskless controller) for DR	Nos	1		

Note : Bidder has to mention quantity of the item over and above the mentioned quantity which shall be sufficient to meet the scope/ objective of State Data Center.

1.3.6 Bill of Quantity: Software Licenses

Sl.No	Item description	UOM	QTY X	Make	Mode I
	Software for Web Server				
	MS Windows Enterprise Server OS with adequate no. of licenses as per the hardware mentioned above with updates, patches, OEM support pack etc. valid for project period	Lic	2		
	Linux Operating System with adequate no. of licenses as per the hardware mentioned above with updates, patches, OEM support pack etc. valid for project period	Lic	1		
	License for use of the server over Internet by citizen « Windows Server External Connector » due to some application designed for IIS	Lic	1		
	64 bit Enterprise latest version Operating System . Latest version of UNIX Operating System (64 bit) with media and documentation for the system to be provided. The OS should be supplied with CPU based license. with updates, patches, OEM support pack etc. valid for project period	Lic	2		
	Software for Application Server				
	MS Windows Enterprise Server OS with adequate no. of licenses as per the hardware mentioned above with updates, patches, OEM support pack etc. valid for project period	Lic	2		
	Linux Operating System with adequate no. of licenses as per the hardware mentioned above with updates, patches, OEM support pack etc. valid for project period	Lic	1		
	64 bit Enterprise latest version Operating System. Latest	Lic	2		

SI.No	Item description	UOM	QTY X	Make	Mode I
	version of UNIX Operating System (64 bit) with media and documentation for the system to be provided. The OS should be supplied with CPU based license. Moreover the Proposed Unix Operating system should be compatible with the middleware software and the RDBMS which shall be deployed on the proposed servers.				
	Tomcat		1		
	Software for Database Server				
	MS Windows Enterprise Server OS with adequate no. of licenses as per the hardware mentioned above with updates, patches, OEM support pack etc. valid for project period	Lic	2		
	Enterprise MS-SQL DBMS along with adequate no. of licenses as per the hardware mentioned above with updates, patches, OEM support pack etc. valid for project period	Lic	1+1		
	Linux Operating System with adequate no. of licenses as per the hardware mentioned above with updates, patches, OEM support pack etc. valid for project period	Lic	1		
	64 bit post-gress / my-sql open source database management software.	Lic	1		
	Software for Staging Server				
	MS Windows Enterprise Server OS with adequate no. of licenses as per the hardware mentioned above with updates, patches, OEM support pack etc. valid for project period	Lic	1		
	Enterprise MS-SQL DBMS along with adequate no. of licenses as per the hardware mentioned above with updates, patches, OEM support pack etc. valid for	Lic	1		

SI.No	Item description	UOM	QTY X	Make	Mode I
	project period				
	one set of 64 bit Enterprise Red Hat Linux/UNIX Operating system for proposed hardware.	Lic	1		
	Backup Software	Nos	1		
	Software Licenses for Backup S/W	Nos	1		
	Bidder has to choose appropriate Enterprise OS with adequate no. of licenses as per the hardware mentioned above with updates, patches, OEM support pack etc. valid for a project period. (Mention OS)	Lic	1		
	SAN Storage Licenses	No's	As per Bidder's Sol		
	Directory, DNS, DHCP Service				
	Software Licenses for Directory Service	Lic	1+1		
	Bidder has to choose appropriate Enterprise OS with adequate no. of licenses as per the hardware mentioned above with updates, patches, OEM support pack etc. valid for a project period. (Mention OS)	Lic	2		
	DNS, DHCP Software	Nos	1+1		
	Client license of directory services for 50 users	Lic	1		
	Management Solution - Software	Nos	1		
	Software Licenses for Management Server	Nos	1		
	Bidder has to choose appropriate Enterprise OS with adequate no. of licenses as per the hardware mentioned above with updates, patches, OEM support pack etc. valid for a project period. (Mention OS)	Lic	1		
	Antivirus Software				
	Antivirus Software Licenses for 50 users	Nos	1		
	Bidder has to choose appropriate Enterprise OS with adequate no. of licenses as per the hardware mentioned	Lic	1		

SI.No	Item description	UOM	QTY X	Make	Mode I
	above with updates, patches, OEM support pack etc. valid for a project period. (Mention OS)				
	Proxy Server Hardware (alongwith adequate no of OS & software licenses)	Nos	2		

The bidder will ensure that prices/cost for all the software licenses discovered during the bid process will be valid for entire period of contract

1.3.7 Bill of Quantity : Additional Component

SI.No	Item description	UOM	QTY X	Unit Rate INR Y	Make	el Mod
1						
2						
3						

Note : Bidder has to mention quantity of the item over and above the mentioned quantity which shall be sufficient to meet the scope/ objective of State Data Center.

1.4 Annexure II: Indicative Proposed SDC Layout

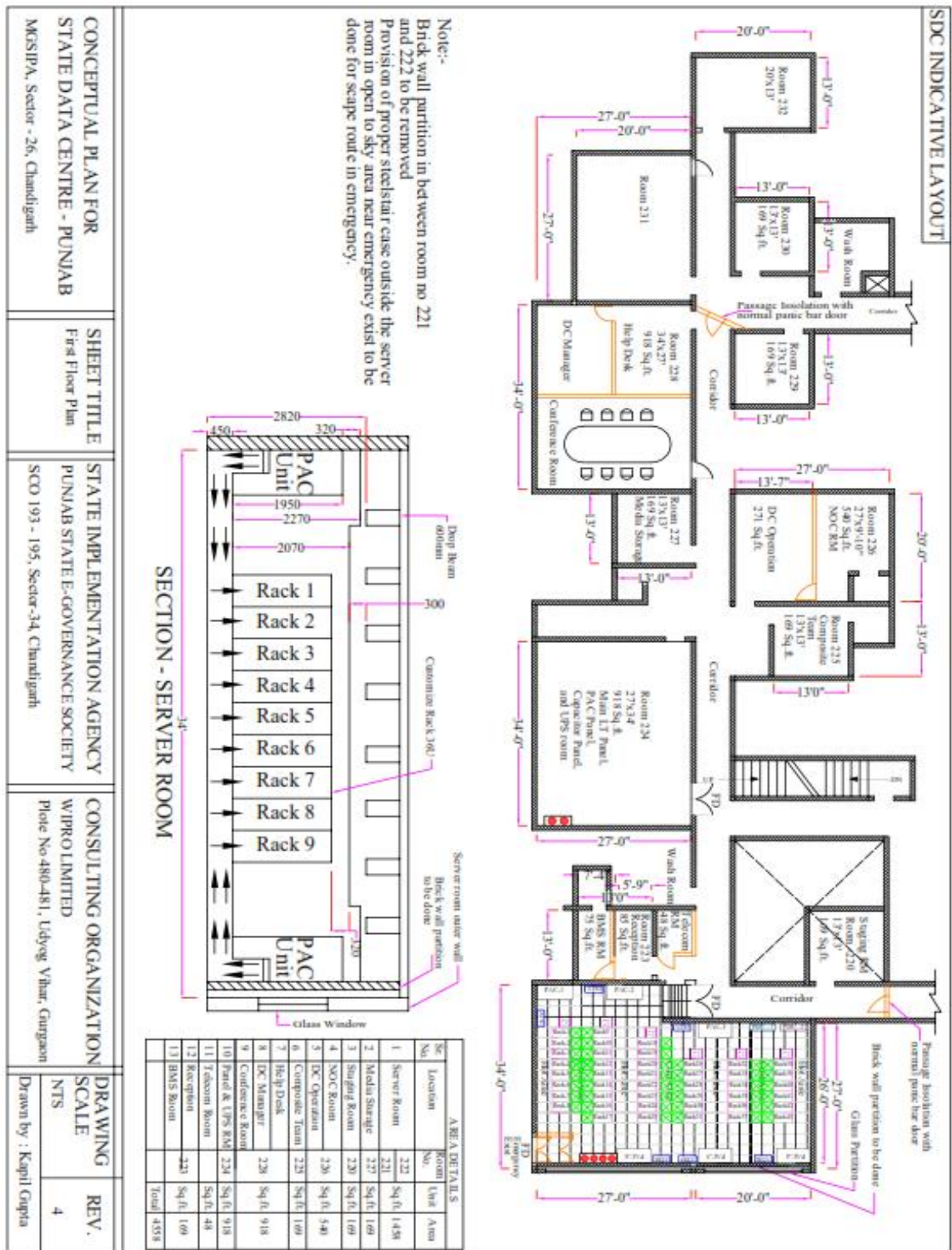

Final Basic SDC Layout layout will be submitted by the DCO

1.5 Indication Layout plan for Main Sub-station and DG station

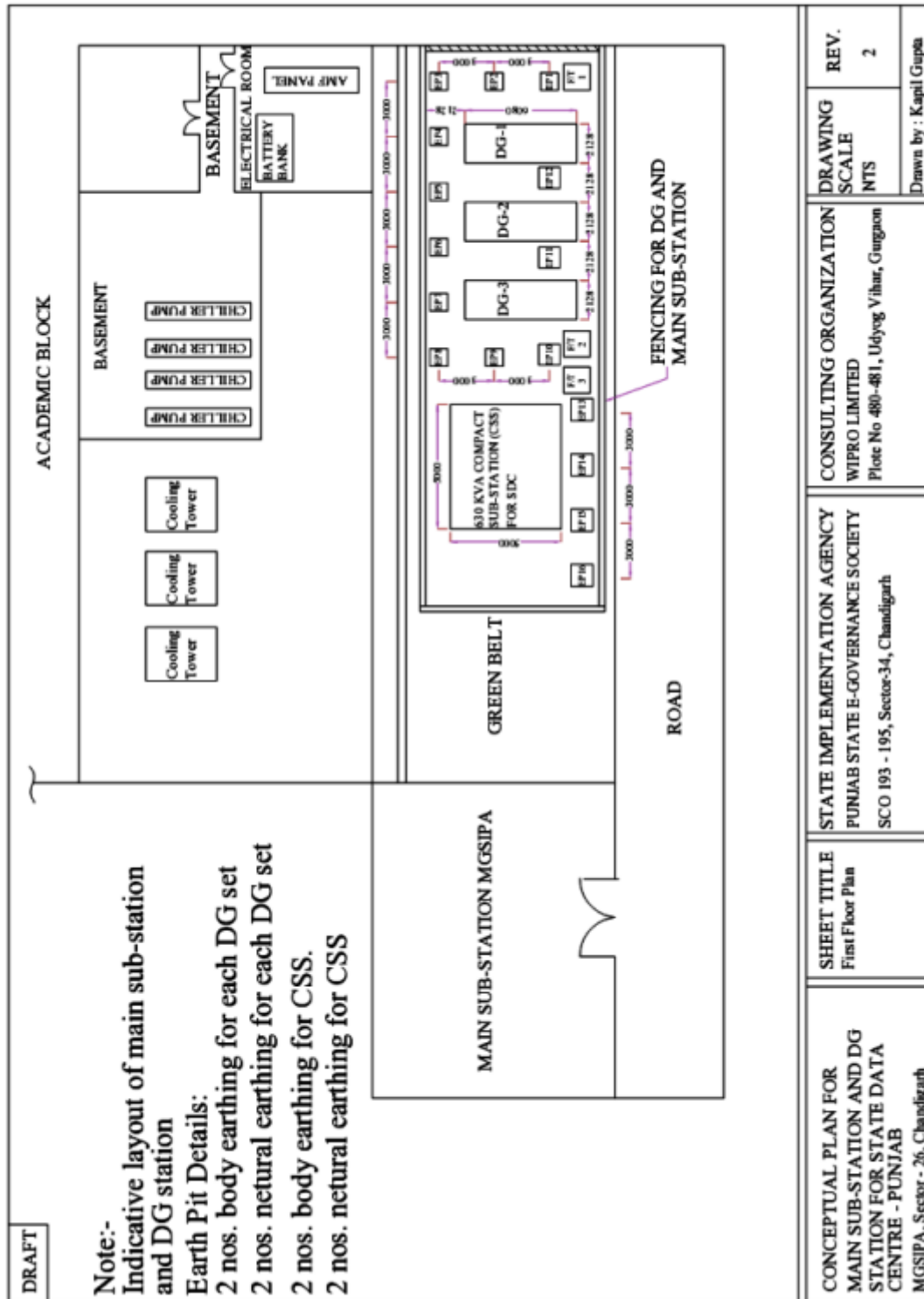

Final Layout plan for Main Sub-station and DG station will be submitted by the DCO

1.6 Annexure III : Single Line Diagram (Electrical) - Tentative

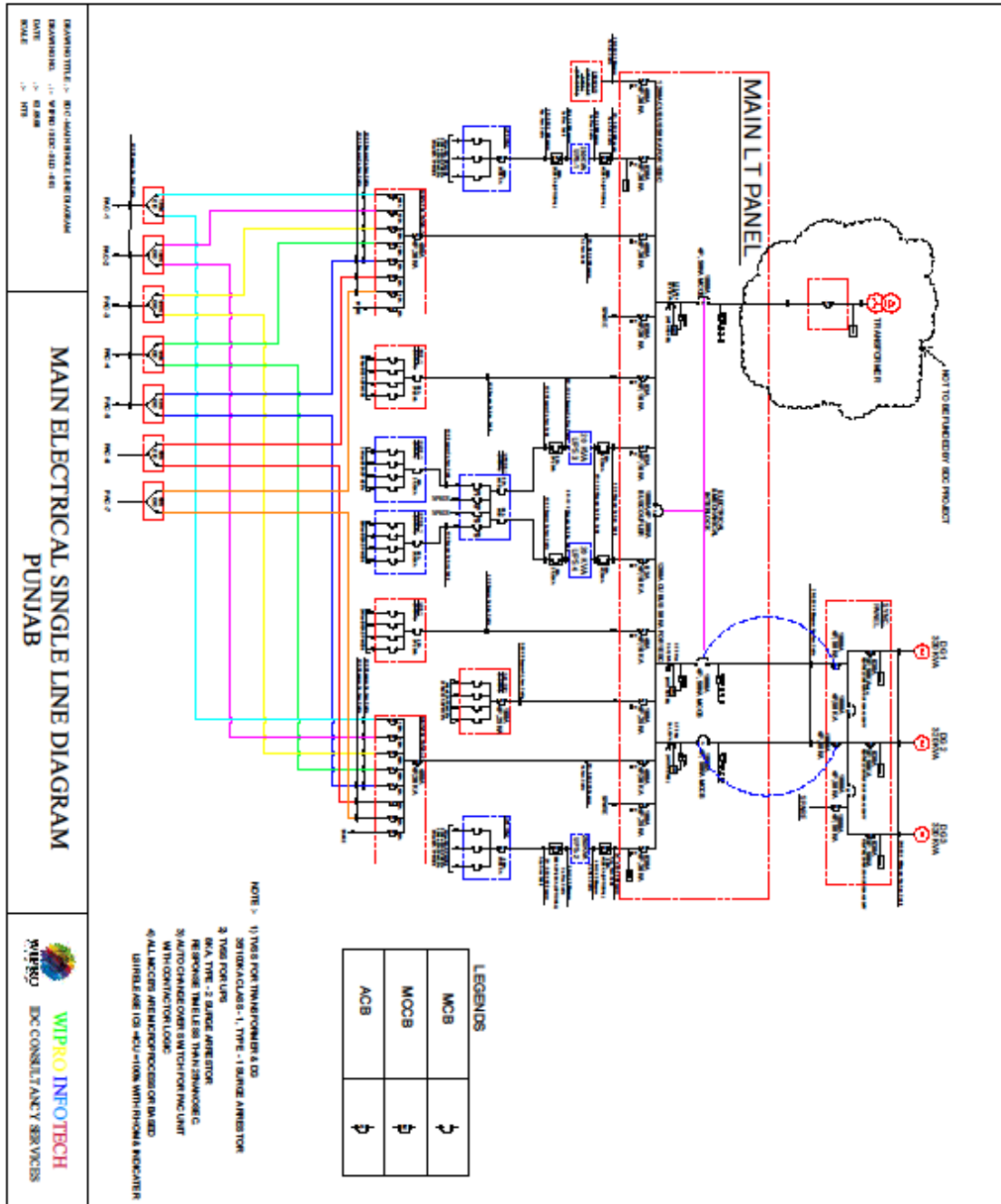

The DCO has to visit & examine SDC site thoroughly and submit the final SLD accordingly

1.7 Annexure IV: Load Calculation Sheet

Sr. No.	Requirement of power		
1	UPS Capacity for Server farm area	KV A	232.2
2	Power Requirement for Auxiliary Area (lighting load)	KV A	7.75
3	UPS Capacity for the NOC, BMS and Staging Area	KV A	12
4	Power Requirement for Precision Air-Conditioning in the Server Farm Area	KV A	120.9
5	Power Requirement for Comfort Air-Conditioning in the Auxiliary Area	KV A	58.13
	Total		431
	(Power requirement for PAC + Power requirement for Comfort AC + Power requirement for auxiliary area + Power required for UPS for Server Farm Area+ Power required for the NOC, BMS & Staging Area) x Safety factor (20%)	KV A	517.2
A	UPS rating	232.2 KVA	
	UPS required 2 x 232.2 KVA	2 Nos	
B	Min transformer rating required	630 KVA	
	No. of transformer required	1	
C	DG rating	32 0	
	No. of DG required	3	

Site constraint

- Bidder shall visit and examine the site thoroughly and get all the relevant information related to site constraints and submit the solution bid accordingly.
 - Any additional scope which is to be carried out due to site constraint should be mentioned in the BOQ as one line item.
 - No separate line items for each scope related to site constraint should be provided in the Commercial Bid.
 - Bidder will provide the lump sum cost for the entire scope related to site constraint.
 - No additional claim related to site constraint other than the lump sum cost approved by State Implementation Agency (SIA) in the BOQ will be entertained by the SIA.
 - All the allied & implied work shall be in the scope of bidder for satisfactory operation of the State Data Centre (SDC).
 - Scope related to functionality of each equipment as per the design requirement shall be Bidder Scope of work.
 - The Bidder shall carry out all the tasks in accordance with the requirement of SDC with due diligence and it shall be the responsibility of the Bidder to fully meet all the requirements of State Data Centre(SDC).